

SKF

Popular bearing range

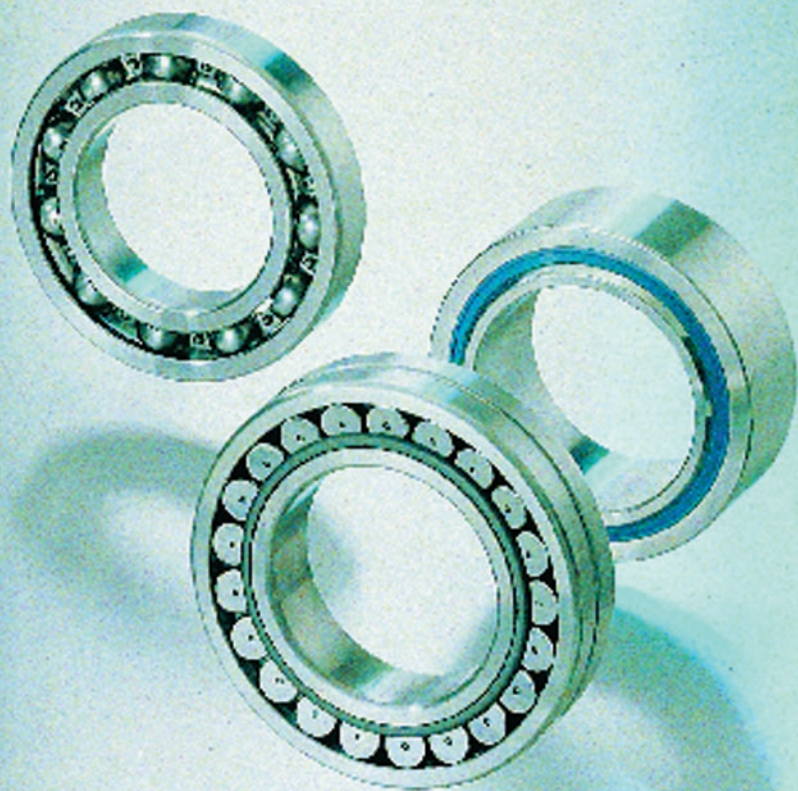

Download the SKF bearing catalog

SKF is an international industrial Group operating in some countries and is world leader in bearings.

The company was founded in 1907 following the invention of the self-aligning ball bearing by Sven Wingquist and, after only a few years, SKF began to expand all over the world.

Today, SKF has some 43 000 employees and more than 80 manufacturing facilities spread throughout the world. An international sales network includes a large number of sales companies and some 20 000 distributors and retailers. Worldwide availability of SKF products is supported by a comprehensive technical advisory service.

The key to success has been a consistent emphasis on maintaining the highest quality of its products and services. Continuous investment in research and development has also played a vital role, resulting in many examples of epoch-making innovations.

The business of the Group consists of bearings, seals, special steel and a comprehensive range of other high-tech industrial components. The experience gained in these various fields provides SKF with the essential knowledge and expertise required in order to provide the customers with the most advanced engineering products and efficient service.

© Copyright SKF 1997

The contents of this catalogue are the copyright of the publishers and may not be reproduced (even extracts) unless permission is granted. Every care has been taken to ensure the accuracy of the information contained in this catalogue but no liability can be accepted for any loss or damage whether direct, indirect or consequential arising out of the use of the information contained here in.

Catalogue **4007/I E**
Reg. 47 · 10 000 · 1997-08

Printed in Denmark by Scanprint as

Introduction 3

1

Recommendations and advice 17

2

Product data 39

3

Design of bearing arrangements 187

4

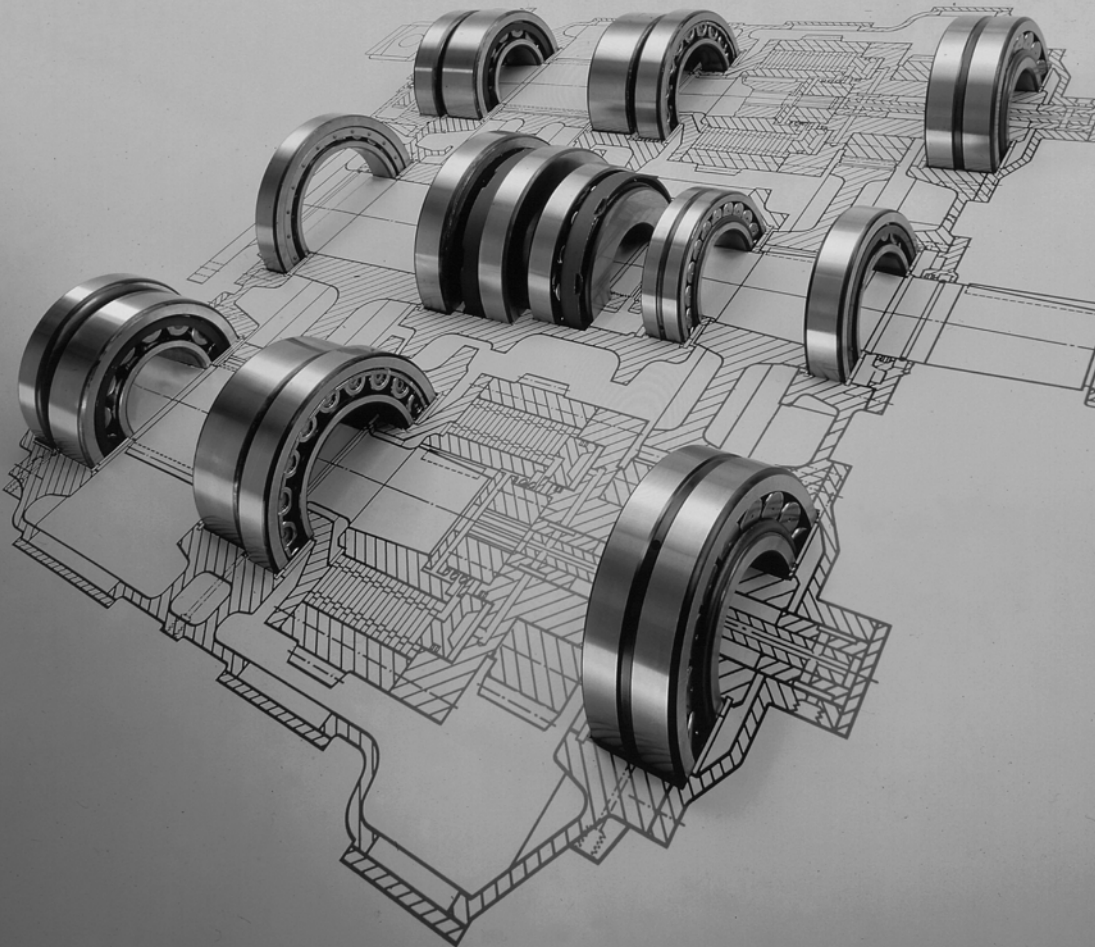

Introduction

Before starting	page 3
Why SKF is a good choice	page 4
Make use of the “Trouble-Free Operation” concept	page 5
Watch the packaging	page 6
SKF designations explained	page 8
The products in this catalogue.....	page 10

Before starting

This catalogue is arranged so as to allow all the important information about the desired product and its use to be found quickly. The contents are divided into four sections which are clearly indicated by an edge marking.

Thus, the desired information is easily found, whether it concerns a particular product, or the answer to a specific problem. Each of the four sections also has its own contents list.

For the sake of clarity, all figures and tables which are referred to in the text are numbered.

All information relating to specific products is given immediately preceding the tables listing those products. General information and information common to several products are to be found in sections 1 and 2. References in the text to these sections generally give the number of the page where more detailed information will be found.

This catalogue shows the popular range of SKF ball, roller and plain bearings. These are products which are in regular demand and are used in a wide variety of applications. The many users of these bearings bear witness to the many advantages. These SKF products

- can normally be supplied from stock, or at short notice, and
- will still be available many years from now,

and on a worldwide basis. Thus purchasing can be planned and stocking simplified, without unnecessary tying up of capital. SKF products embody other advantages too. They are of the highest quality and represent innovative technology as well as exceptional value for money in respect of performance.

This catalogue is mainly intended for end users and for maintenance purposes. The bearing data have, therefore, been kept to a minimum.

NB.

When developing new designs, it is recommended that the SKF General Catalogue and/or Product Catalogues are referred to; see also section 4 “Design of bearing arrangements”, page 185.

Why SKF is a good choice

“Made by SKF” is not just a statement indicating who has made the bearing, it is recognised throughout the world as a hallmark of quality. Products equipped with SKF bearings underline the importance attached by the manufacturer of those products to quality.

SKF ball, roller and plain bearings represent the latest state of the art. In many cases they have set the standards by which such products are judged and have thus driven the technical advancement of bearing technology. The advanced technology used for their production provides SKF products with reserves of performance or tangible total cost benefits to the user in the form of extended service life or reduced energy consumption.

The sales organisation is also an important factor for the customer. SKF authorised distributors are not only competent, they are close at hand, with stock including much of the range shown in this catalogue. They are

able to identify SKF equivalents for other makes from lists or using computer software. SKF products not in stock are ordered from the SKF central stock via on-line facilities. Their product knowledge is kept up to date by SKF training sessions.



Make use of the “Trouble-Free Operation” concept

Bearing damage can cause unplanned stoppages and loss of production. This can be very costly, particularly where capital intensive plant is concerned.

Use SKF bearings

It is desirable that every SKF bearing has a long service life and gives no trouble in operation. Considerable investments in research and development enable SKF to produce bearings of the highest quality. However, bearing quality alone cannot guarantee trouble-free operation, since the life of a bearing is influenced by external factors.

Reduce the risks

To perform properly, all machines and mechanical components must be kept in proper condition. Bearings, for example, should not be too tightly clamped or be subjected to ex-

treme temperatures, and they must be protected against damp and contaminants.

Use SKF mounting tools ...

The methods as well as the tools used to mount bearings must be suitable for the job, so that the bearings are not damaged during installation, before they even start to operate.

... and maintenance equipment

To achieve long life, bearings must be properly lubricated and maintained, and the operating conditions controlled.

Proper bearing maintenance is fundamental to good performance. The SKF concept of “Trouble-Free Operation” shows how bearing failures can be avoided and allows maximum exploitation of bearing potential. SKF offers a comprehensive range of products and services which eliminate uncertainties in bearing mounting and maintenance, see page 25.

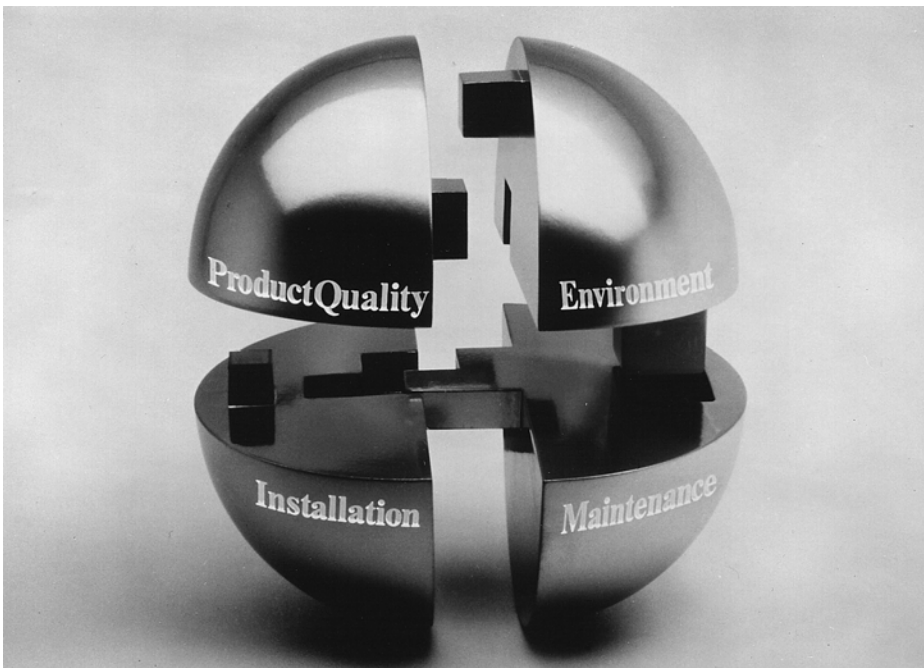

Watch the packaging

SKF bearings are properly packed, and the packages provide optimum protection to the product using a minimum of packaging materials.

When buying SKF bearings check that they are always in their original packages. As it is not possible to open a single pack without breaking the seal, an unopened package is a guarantee that the product is in “mint” condition, and has not been subjected to detrimental environmental influences. In cases where the authorised distributor takes an SKF bearing from a bulk package, the bearing should be put it into a plastic container or bag which can be sealed, and the package clearly labelled.

Single packages

Singly packaged bearings are those best protected against environmental influences, particularly if, for example, for certain replacement bearings, it must be expected that they will be in store for quite a long time.

SKF bearings having an outside diameter up to and including 30 mm are packaged in fully sealed plastic pouches (fig 1).

Larger bearings and bearing units weighing up to and including 3,5 kg are wrapped in dust and oil-resistant foil and then put in cardboard boxes (fig 2).

Bearings and bearing units weighing more than 3,5 kg and up to and including 30 kg are singly packed in partly decorated cardboard boxes (fig 3).

Bearings weighing more than 30 kg are delivered in wooden boxes or crates (fig 4).

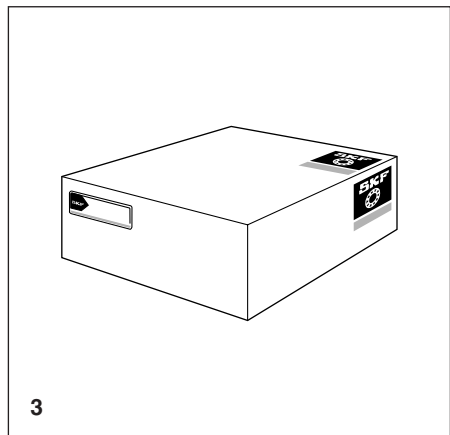
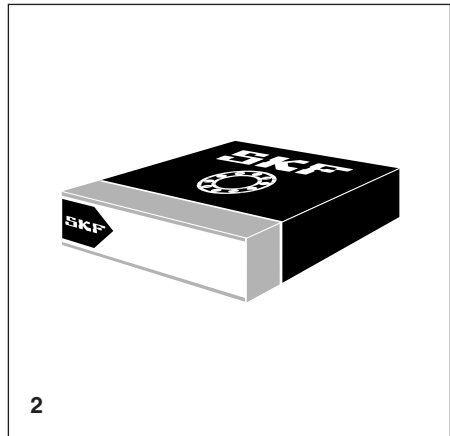

Bulk packages

For customers using moderate to large numbers of bearings, SKF offers bulk packages in order to limit the quantity of packaging materials and the cost of disposing of these materials. Special packages suited to customer production routines are also available.

Labelling and identification

The complete product designation is marked on all single packages and normally also the country of origin (fig 5). The packaging date is coded.

Environmentally friendly

SKF packaging materials are not damaging to the environment and most can be recycled. PVC is not used by SKF. All materials including printing inks, lacquers and glues are chosen to be environmentally friendly.

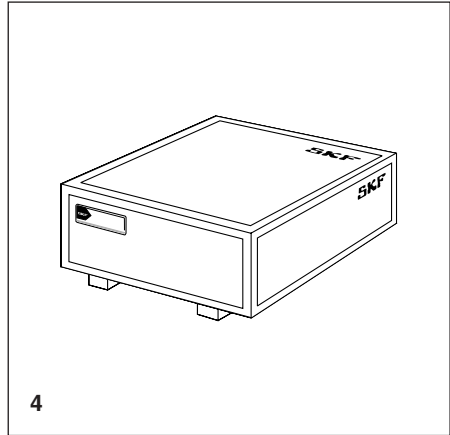

4

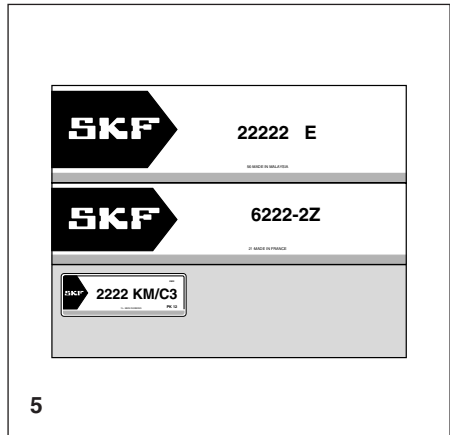

5

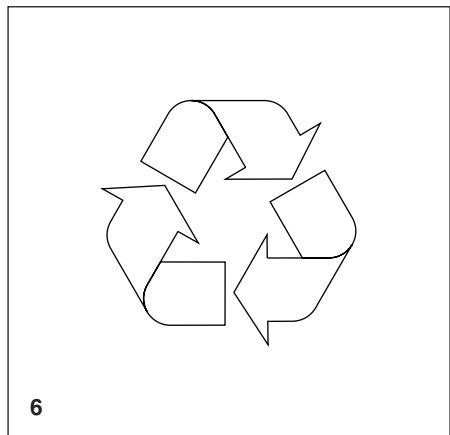

6

SKF designations explained

The standard metric bearings have a characteristic basic designation which identifies the type of bearing and its standardised boundary dimensions. This basic designation consists of 3, 4 or 5 figures, or a combination of letters and figures. It gives the bearing type, Dimension Series and the bore diameter in that order. The basic designation, together with a possible suffix indicating a change in the internal design, but without the bore diameter or size indication, constitutes the series designation, being common to several bearings of the same type but of increasing size.

The figure opposite shows the designation system for metric ball and roller bearings in diagram form.

Bore diameter identification

As shown opposite, the last two figures of a designation give the bore diameter in millimetres divided by five. The size identification of the smallest and largest bearings differs from this rule: for bearings having bore diameters smaller than 10 mm and equal to or larger than 500 mm, the diameter is given uncoded in millimetres preceded by an oblique stroke (the / is not used on some of the small bearings), e.g. bearing 623 has a bore diameter of 3 mm and bearing 618/8 a bore diameter of 8 mm.

Bearings having bore diameters of 10, 12, 15 and 17 have the following bore diameter codes: 00 = 10 mm, 01 = 12 mm, 02 = 15 mm, and 03 = 17 mm.

Supplementary designations

Suffixes are used to identify changes compared with the original design, or variants of the standard design. They follow a given system, being divided into groups, and when several suffixes identifying more than one variant/feature are used, they are listed in a given order following the basic designation.

The suffixes which appear in this catalogue and which are frequently encountered are listed and explained in the text preceding the relevant bearing table section under the heading "Supplementary designations".

More detailed information concerning the SKF designation system for rolling bearings and accessories will be found in the SKF brochure PI 100.

Designations for other products

The designations for plummer block housings, adapter and withdrawal sleeves, lock nuts etc. follow a similar system to that for rolling bearings and are covered to some extent in the brochure PI 100. The designations of spherical plain bearings, rod ends and GLYCODUR plain bearings follow other rules. The bore diameter of these products is always given uncoded in mm, and for GLYCODUR products, the other dimensions are also given in the designation.

Diagram of the basic designation system for rolling bearings

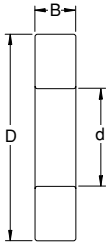

Radial bearing

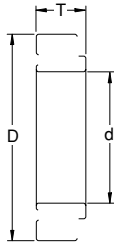

Taper roller bearing

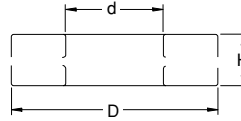

Thrust bearing

Bearing types

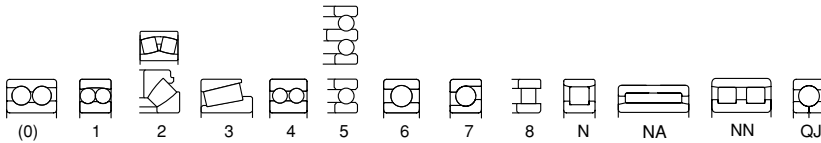

Radial bearings

Width (B, T)



Thrust bearing

Height (H)

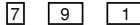

Outside diameter (D)

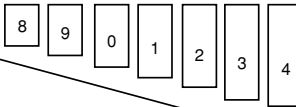

Dimension series

Bearing size $d/5$

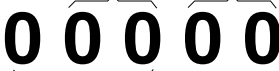

Bearing series

Bearing type designation

- 0 Angular contact ball bearings, double row
- 1 Self-aligning ball bearings
- 2 Spherical roller bearings and spherical roller thrust bearings
- 3 Taper roller bearings
- 4 Deep groove ball bearings, double row
- 5 Thrust ball bearings
- 6 Deep groove ball bearings, single row
- 7 Angular contact ball bearings, single row
- 8 Cylindrical roller thrust bearings
- N Cylindrical roller bearings, single row.
Following the letter N, one or two letters may be added, denoting the flange configuration, e.g. NJ, NU, NUP etc.
- NA Needle roller bearings according to ISO 15-1981.
- NK Needle roller bearings with other dimensions are designated NK(l)
- NN Cylindrical roller bearings, double or multi row – otherwise like "N"
- QJ Four-point contact ball bearings

The bearing type identification 0 for double row angular contact ball bearings is not used in the designation and is therefore shown in brackets in the "Bearing types" figure.

The products in this catalogue

The range of products shown in this catalogue comprises some 5 000 ball, roller and plain bearings, track runner bearings, bearing units, bearing housings and accessories. In order to find bearings, for which the designation is known, the following index has been compiled. The first section is arranged in numerical order (first figure, second figure, third figure etc. so that 108 comes before 12) and is followed by an alphabetical list.

Because of the large number of products, most are listed by their series designation only, e.g. 62-2RS1 for all deep groove ball bearings of series 62 which have seals at both sides. The page number shown is always the first page on which a product of the particular series can be found.



Product index in numerical order

Designation	Product	Page
07000	Single row taper roller bearings, inch size	97
09000	Single row taper roller bearings, inch size	97
108	Self-aligning ball bearing	52
112	Self-aligning ball bearing	52
11500	Single row taper roller bearings, inch size	97
12	Self-aligning ball bearings	52
126 to 129	Self-aligning ball bearings	52
13	Self-aligning ball bearings	52
135	Self-aligning ball bearing	52
1300	Single row taper roller bearings, inch size	97
15000	Single row taper roller bearings, inch size	97
160	Single row deep groove ball bearings	44
160-2Z	Single row deep groove ball bearings	44
161	Single row deep groove ball bearings	44
17262(00)-2RS1	Y-bearings with standard inner ring	134
18600	Single row taper roller bearings, inch size	98
18700	Single row taper roller bearings, inch size	98
1900	Single row taper roller bearings, inch size	97
213	Spherical roller bearings	85
22	Self-aligning ball bearings	52
222	Spherical roller bearings	85
223	Spherical roller bearings	85
23	Self-aligning ball bearings	52
230	Spherical roller bearings	86
231	Spherical roller bearings	86
232	Spherical roller bearings	86
2344(00)	Double direction angular contact thrust ball bearings	121
2347(00)	Double direction angular contact thrust ball bearings	121
239	Spherical roller bearings	88
240	Spherical roller bearings	86
241	Spherical roller bearings	86
25500	Single row taper roller bearings, inch size	97
25800	Single row taper roller bearings, inch size	97
2700	Single row taper roller bearings, inch size	97
292	Spherical roller thrust bearings	109
293	Spherical roller thrust bearings	109
294	Spherical roller thrust bearings	109
29600	Single row taper roller bearings, inch size	98
302	Single row taper roller bearings	92
303	Single row taper roller bearings	92
313	Single row taper roller bearings	92
32	Double row angular contact ball bearings	61
32 A-2RS1	Double row angular contact ball bearings	61
32 A-2Z	Double row angular contact ball bearings	61
320 X	Single row taper roller bearings	92
322	Single row taper roller bearings	92
323	Single row taper roller bearings	92
329	Single row taper roller bearings	95
33	Double row angular contact ball bearings	61
33 A-2RS1	Double row angular contact ball bearings	61
33 A-2Z	Double row angular contact ball bearings	61
330	Single row taper roller bearings	93
331	Single row taper roller bearings	92
332	Single row taper roller bearings	92
3400	Single row taper roller bearings, inch size	97
3500	Single row taper roller bearings, inch size	97
355	Single row taper roller bearings, inch size	97
365	Single row taper roller bearings, inch size	98
3700	Single row taper roller bearings, inch size	98
385	Single row taper roller bearings, inch size	98
3900	Single row taper roller bearings, inch size	98
39500	Single row taper roller bearings, inch size	98
42 A	Double row deep groove ball bearings	49
43 A	Double row deep groove ball bearings	49
475	Single row taper roller bearings, inch size	98
47600	Single row taper roller bearings, inch size	98
48200	Single row taper roller bearings, inch size	98
511	Single direction thrust ball bearings	101
512	Single direction thrust ball bearings	101
513	Single direction thrust ball bearings	101
514	Single direction thrust ball bearings	101



Product index in numerical order

Designation	Product	Page
522	Double direction thrust ball bearings.....	103
523	Double direction thrust ball bearings.....	103
524	Double direction thrust ball bearings.....	103
525	Single row taper roller bearings, inch size.....	97
53000	Single row taper roller bearings, inch size.....	97
532	Single direction thrust ball bearings.....	102
533	Single direction thrust ball bearings.....	102
535	Single row taper roller bearings, inch size.....	98
56000	Single row taper roller bearings, inch size.....	98
575	Single row taper roller bearings, inch size.....	98
595	Single row taper roller bearings, inch size.....	98
60	Single row deep groove ball bearings.....	43
60-RS1	Single row deep groove ball bearings.....	43
60-2RS1	Single row deep groove ball bearings.....	43
60-2RZ	Single row deep groove ball bearings.....	43
60-Z	Single row deep groove ball bearings.....	43
60-2Z	Single row deep groove ball bearings.....	43
618	Single row deep groove ball bearings.....	43
618-2RS1	Single row deep groove ball bearings.....	43
618-2RZ	Single row deep groove ball bearings.....	44
618-2Z	Single row deep groove ball bearings.....	43
619	Single row deep groove ball bearings.....	43
619-2RS1	Single row deep groove ball bearings.....	44
619-2RZ	Single row deep groove ball bearings.....	44
619-2Z	Single row deep groove ball bearings.....	43
62	Single row deep groove ball bearings.....	43
62-RS1	Single row deep groove ball bearings.....	43
62-2RS1	Single row deep groove ball bearings.....	43
62-2RZ	Single row deep groove ball bearings.....	44
62-Z	Single row deep groove ball bearings.....	43
62-2Z	Single row deep groove ball bearings.....	43
622-2RS1	Single row deep groove ball bearings.....	44
623-2RS1	Single row deep groove ball bearings.....	44
628-2Z	Single row deep groove ball bearings.....	43
63	Single row deep groove ball bearings.....	43
63-RS1	Single row deep groove ball bearings.....	44
63-2RS1	Single row deep groove ball bearings.....	44
63-Z	Single row deep groove ball bearings.....	44
63-2Z	Single row deep groove ball bearings.....	43
630-2RS1	Single row deep groove ball bearings.....	43
6300	Single row taper roller bearings, inch size.....	98
64	Single row deep groove ball bearings.....	44
64000	Single row taper roller bearings, inch size.....	98
6500	Single row taper roller bearings, inch size.....	98
655	Single row taper roller bearings, inch size.....	98
675	Single row taper roller bearings, inch size.....	98
70 B	Single row angular contact ball bearings.....	60
70 CD	Single row angular contact ball bearings.....	115
719 CD	Single row angular contact ball bearings.....	115
72 CD	Single row angular contact ball bearings.....	115
72 B	Single row angular contact ball bearings.....	59
73 B	Single row angular contact ball bearings.....	59
74 B	Single row angular contact ball bearings.....	59
811	Cylindrical roller thrust bearings.....	105
812	Cylindrical roller thrust bearings.....	105

Product index in alphabetical order

Designation	Product	Page
AH 22	Withdrawal sleeves	163
AH 23	Withdrawal sleeves	162
AH 240	Withdrawal sleeves	162
AH 241	Withdrawal sleeves	162
AH 3	Withdrawal sleeves	162
AH 30	Withdrawal sleeves	163
AH 31	Withdrawal sleeves	163
AH 32	Withdrawal sleeves	163
AHX 23	Withdrawal sleeves	162
AHX 3	Withdrawal sleeves	162
AHX 30	Withdrawal sleeves	162
AHX 31	Withdrawal sleeves	162
AHX 32	Withdrawal sleeves	162
AOH 23	Withdrawal sleeves, for oil injection method	163
AOH 240	Withdrawal sleeves, for oil injection method	164
AOH 241	Withdrawal sleeves, for oil injection method	164
AOH 30	Withdrawal sleeves, for oil injection method	163
AOH 31	Withdrawal sleeves, for oil injection method	163
AS	Thrust washers for needle roller and cage thrust assemblies	107
ASNA .. V	Seal sets for SNH plummer block housings	153
ASNH	End covers for SNH plummer block housings	153
AXK	Needle roller and cage thrust assemblies	107
BA	Thrust ball bearings	101
BK	Drawn cup needle roller bearings	76
ECY 2	End covers for Y-bearing housings	138
FRB	Locating rings for bearing housings	156
FS	Felt strips for bearing housings	155
FY	Y-bearing units with flanged housing	141
FYJ	Y-bearing units with flanged housing	141
FYK	Y-bearing units with flanged housing	141
FYTB	Y-bearing units with flanged housing	143
FYTBK	Y-bearing units with flanged housing	143
GAC .. F	Angular contact spherical plain bearings, maintenance-free	170
GE .. C	Spherical plain bearings, maintenance-free	169
GE .. E	Spherical plain bearings, steel-on-steel	167
GE .. ES	Spherical plain bearings, steel-on-steel	167
GE .. ES-2RS	Spherical plain bearings, steel-on-steel	167
GE .. TA-2RS	Spherical plain bearings, maintenance-free	169
GE .. TE-2RS	Spherical plain bearings, maintenance-free	169
GE .. TGR	Spherical plain bearings, maintenance-free	169
GEG .. ES	Spherical plain bearings, steel-on-steel	168
GEH .. C	Spherical plain bearings, maintenance-free	169
GEH .. ES-2RS	Spherical plain bearings, steel-on-steel	167
GEM .. ES-2RS	Spherical plain bearings, steel-on-steel	168
GLY.PBG .. F	GLYCODUR flanged bushings	184
GLY.PG .. A	GLYCODUR bushings	181
GLY.PG .. F	GLYCODUR bushings	181
GLY.PXG .. A	GLYCODUR thrust washers	185
GLY.PXG .. F	GLYCODUR thrust washers	185
GS 811	Housing washers for cylindrical roller and needle roller thrust bearings	107
GS 812	Housing washers for cylindrical roller and needle roller thrust bearings	107
GX .. F	Spherical plain thrust bearings, maintenance-free	170
H 2	Adapter sleeves	160
H 23	Adapter sleeves	160
H 3	Adapter sleeves	160
H 30	Adapter sleeves	161
H 31	Adapter sleeves	161
H 913800	Single row taper roller bearings, inch size	98
HJ 2 EC	Angle rings for cylindrical roller bearings	66
HJ 22 EC	Angle rings for cylindrical roller bearings	66
HJ 23 EC	Angle rings for cylindrical roller bearings	66
HJ 3 EC	Angle rings for cylindrical roller bearings	66
HK	Drawn cup needle roller bearings	76
HK RS	Drawn cup needle roller bearings	76
HK.2RS	Drawn cup needle roller bearings	76
HM 220100	Single row taper roller bearings, inch size	98
HM 801300	Single row taper roller bearings, inch size	97
HM 803100	Single row taper roller bearings, inch size	97
HM 88500	Single row taper roller bearings, inch size	97
HM 88600	Single row taper roller bearings, inch size	97
HM 89400	Single row taper roller bearings, inch size	97



Product index in alphabetical order

Designation	Product	Page
HM 903200	Single row taper roller bearings, inch size	97
HM 911200	Single row taper roller bearings, inch size	98
KR	Cam followers.....	128
KRV	Cam followers.....	128
L 44600	Single row taper roller bearings, inch size	97
L 68100	Single row taper roller bearings, inch size	97
LM 102900	Single row taper roller bearings, inch size	97
LM 11700	Single row taper roller bearings, inch size	97
LM 48500	Single row taper roller bearings, inch size	97
LM 501300	Single row taper roller bearings, inch size	97
LM 67000	Single row taper roller bearings, inch size	97
LS	Raceway washers for needle roller thrust bearings.....	107
M 12600	Single row taper roller bearings, inch size	97
M 802000	Single row taper roller bearings, inch size	97
M 86600	Single row taper roller bearings, inch size	97
M 88000	Single row taper roller bearings, inch size	97
N 2	Single row cylindrical roller bearings.....	66
N 3	Single row cylindrical roller bearings.....	66
NA 22.2RS	Support rollers	125
NA 48	Needle roller bearings	82
NA 49	Needle roller bearings	81
NA 49 RS	Needle roller bearings	81
NA 49.2RS	Needle roller bearings	81
NA 69	Needle roller bearings	81
NATR	Support rollers	126
NATV	Support rollers	126
NCF 29 V	Single row full complement cylindrical roller bearings	73
NJ 2	Single row cylindrical roller bearings.....	66
NJ 22	Single row cylindrical roller bearings.....	66
NJ 23	Single row cylindrical roller bearings.....	66
NJ 3	Single row cylindrical roller bearings.....	66
NK	Needle roller bearings, without inner ring.....	79
NKI	Needle roller bearings	81
NKIA	Combined needle roller bearings	112
NKIB	Combined needle roller bearings.....	112
NKIS	Needle roller bearings	81
NKS	Needle roller bearings, without inner ring.....	79
NKX	Combined needle roller bearings	113
NN 30	Double row cylindrical roller bearings	118
NNF 50 ADA-2LS	Double row full complement cylindrical roller bearings.....	73
NNU 49	Double row cylindrical roller bearings	118
NU 10	Single row cylindrical roller bearings.....	66
NU 2	Single row cylindrical roller bearings.....	66
NU 22	Single row cylindrical roller bearings.....	66
NU 23	Single row cylindrical roller bearings.....	66
NU 3	Single row cylindrical roller bearings.....	66
NUKR	Cam followers.....	128
NUP 2	Single row cylindrical roller bearings.....	66
NUP 22	Single row cylindrical roller bearings.....	66
NUP 23	Single row cylindrical roller bearings.....	66
NUP 3	Single row cylindrical roller bearings.....	66
NUTR	Support rollers	126
OH 30 H	Adapter sleeves for oil injection method.....	161
OH 31 H	Adapter sleeves for oil injection method.....	161
P	Y-bearing plummer block units	140
PF	Y-bearing flanged units.....	144
PFD	Y-bearing flanged units.....	145
PFT	Y-bearing flanged units.....	146
QJ 2	Four-point contact ball bearings	63
QJ 3	Four-point contact ball bearings	63
RIS 2	Rubber inserts for Y-bearing units	140
RNA 22.2RS	Support rollers, without inner ring	125
RNA 48	Needle roller bearings, without inner ring.....	80
RNA 49	Needle roller bearings, without inner ring.....	79
RNA 49.2RS	Needle roller bearings, without inner ring.....	79
RNA 69	Needle roller bearings, without inner ring.....	79
RSTO	Support rollers, without inner ring.....	124

Product index in alphabetical order

Designation	Product	Page
SA .. C	Rod ends, maintenance-free	177
SA .. E	Rod ends, steel-on-steel	173
SA .. ES	Rod ends, steel-on-steel	173
SA .. TE-2RS	Rod ends, maintenance-free	177
SAKAC .. M	Rod ends, steel-on-bronze	176
SAKB .. F	Rod ends, maintenance-free	178
SC .. ES	Rod ends, steel-on-steel	175
SCF .. ES	Rod ends, steel-on-steel	175
SI .. C	Rod ends, maintenance-free	177
SI .. E	Rod ends, steel-on-steel	173
SI .. ES	Rod ends, steel-on-steel	173
SI .. TE-2RS	Rod ends, maintenance-free	177
SIKAC .. M	Rod ends, steel-on-bronze	176
SIKB .. F	Rod ends, maintenance-free	178
SIQG .. ES	Rod ends, for hydraulic cylinders	174
SIR .. ES	Rod ends, for hydraulic cylinders	174
SIRD .. ES	Rod ends, for hydraulic cylinders	174
SNH 2	Plummer block housings, without seals	155
SNH 5	Plummer block housings, without seals	153
SNH 5-6	Plummer block housings, without seals	153
SNH 2 TA	Plummer block housings, with V-ring seals	154
SNH 2 TC	Plummer block housings, with felt seals	154
SNH 2 TG	Plummer block housings, with double-lip seals	154
SNH 3 TA	Plummer block housings, with V-ring seals	154
SNH 3 TG	Plummer block housings, with double-lip seals	154
SNH 4 TA	Plummer block housings, with V-ring seals	152
SNH 5 TC	Plummer block housings, with felt seals	152
SNH 5 TG	Plummer block housings, with double-lip seals	152
SNH 6 TA	Plummer block housings, with V-ring seals	152
SNH 6 TC	Plummer block housings, with felt seals	152
SNH 6 TG	Plummer block housings, with double-lip seals	152
STO	Support rollers	124
SY	Y-bearing plummer block units	138
SYJ	Y-bearing plummer block units	138
SYK	Y-bearing plummer block units	138
SYT	Pop-Release units	149
TSNA 2 A	V-ring seal sets for SNH plummer block housings	155
TSNA 2 G	Double-lip seal sets for SNH plummer block housings	155
TSNA 3 A	V-ring seal sets for SNH plummer block housings	155
TSNA 3 G	Double-lip seal sets for SNH plummer block housings	155
TSNA 5 A	V-ring seal sets for SNH plummer block housings	153
TSNA 5 C	Felt seal sets for SNH plummer block housings	153
TSNA 5 G	Double-lip seal sets for SNH plummer block housings	153
TSNA 6 A	V-ring seal sets for SNH plummer block housings	153
TSNA 6 C	Felt seal sets for SNH plummer block housings	153
TSNA 6 G	Double-lip seal sets for SNH plummer block housings	153
TU	Y-bearing take-up units	147
U 2	Seating washers for thrust ball bearings with sphered housing washer(s)	102
U 3	Seating washers for thrust ball bearings with sphered housing washer(s)	102
W 619-2Z	Single row deep groove ball bearings of stainless steel	43
W 628-2Z	Single row deep groove ball bearings of stainless steel	43
WS 811	Shaft washers for cylindrical roller and needle roller thrust bearings	107
WS 812	Shaft washers for cylindrical roller and needle roller thrust bearings	107
YAJ 2-2RF	Y-bearings with grub screw locking	133
YAR 2-2F	Y-bearings with grub screw locking	133
YAR 2-2RF	Y-bearings with grub screw locking	133
YAR 2-2RFW	Y-bearings with grub screw locking	133
YAT 2	Y-bearings with grub screw locking	133
YEL 2	Y-bearings with eccentric locking ring	133
YEL 2-2RF	Y-bearings with eccentric locking ring	133
YET 2	Y-bearings with eccentric locking ring	133
YET 2 W	Y-bearings with eccentric locking ring	133



Recommendations and advice

How to find the right replacement bearing	page 17
About bearing storage	page 19
What to remember when mounting bearings	page 20
How to maintain correctly	page 28
How to lubricate properly	page 30
What to remember when dismantling bearings	page 34
What to remember about sealing	page 36

How to find the right replacement bearing

When the bearing is an SKF bearing, the product designation (page 8) provides exact information. Where bearings of other makes are concerned, all SKF authorised distributors can help. They have interchange information, which generally includes appropriate SKF software. Usually, an SKF product of the same type will be provided, as the SKF product range is second to none.

How to identify bearings

Each SKF ball, roller and plain bearing carries a designation which is usually to be found on the side face of the inner and/or outer ring (fig 1). This designation (page 8) identifies the bearing type, size and other features and is also all that is needed when ordering.

If it is not possible to read the designation marking then it is still possible to identify the bearing by

1. looking in the machine specification; this normally states which bearings are installed at the various positions;
2. taking the bearing to an SKF distributor for identification;
3. measuring the bearing.

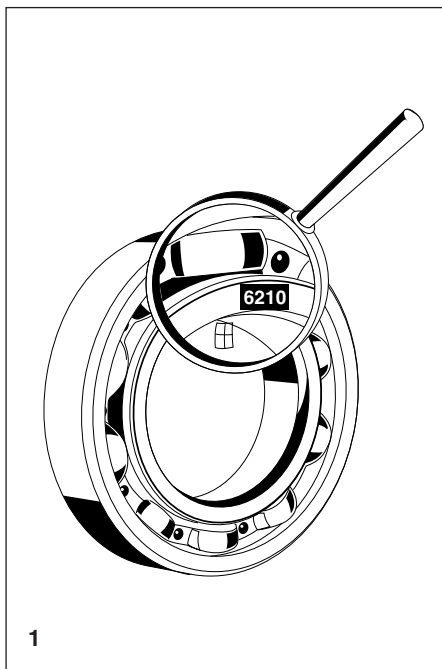

Recommendations and advice

How to identify a bearing by measuring it

It is often possible to identify a bearing from its boundary dimensions. The procedure is as follows:

- measure the bore and outside diameters of the bearing and its width or height (figs 2, 3 and 4),
- turn to the bearing type in the catalogue,
- find the measured bore diameter in the column headed “d”, then the outside diameter under “D” and the width or height under “B”, “T” or “H”,
- follow the appropriate line to the right and the designation will be found in the column headed “Designation”.

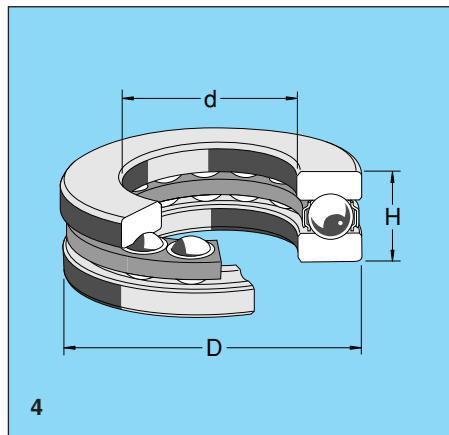
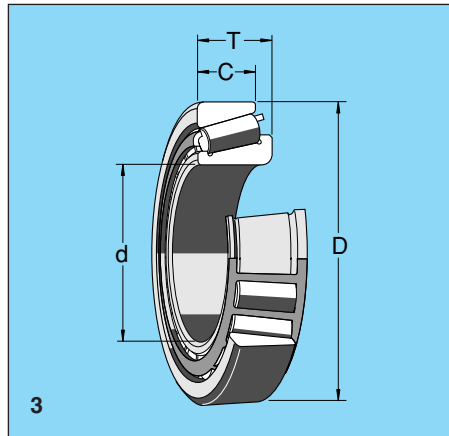
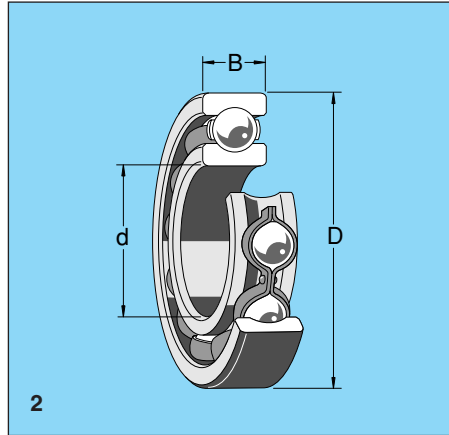

About bearing storage

The ball, roller and plain bearings shown in this catalogue form the SKF popular bearing range and are generally available from stock or at short notice. SKF authorised distributors also carry stocks in order to be able to serve their specific customers. In spite of this, there are good reasons for many bearing users to have their own bearing stores. This is especially true when the replacement bearings are for machines or plant where a stoppage would lead to a total loss of production, or where special bearings are used.

Bearings in original packages

Before being packaged, SKF bearings are treated with a rust inhibiting medium and can be stored for many years. The bearings should be stored lying down, preferably in rooms which are free from vibration, at a relative humidity that does not exceed 60 % and a temperature which is reasonably constant.

NB.

Bearings with shields at both sides (suffix -2Z) should only be stored for a maximum of two years and bearings with seals at both sides (suffix -2RS1) for a maximum of three years. Longer storage of these “lubricated-for-life” bearings is not recommended because the grease with which they are filled will age and

gradually lose its lubricating properties. Such bearings will also have a higher starting torque than new bearings when they have been in storage for some time.

Bearings not in original packages

If bearings are stored without their original packaging, it is necessary to ensure that they are adequately protected against corrosion and contamination. The SKF high-performance, high-viscosity oil LHPT 48 is eminently suitable for the protection of bearings from corrosion, and is a must for any workshop. It protects against rust, repels moisture and lubricates at the same time. To protect bearings against contamination, they should be wrapped in plastic foil (e.g. polyethylene) and kept in a cardboard box or other container.

The full designation of the bearing should be marked on the box or container.

2

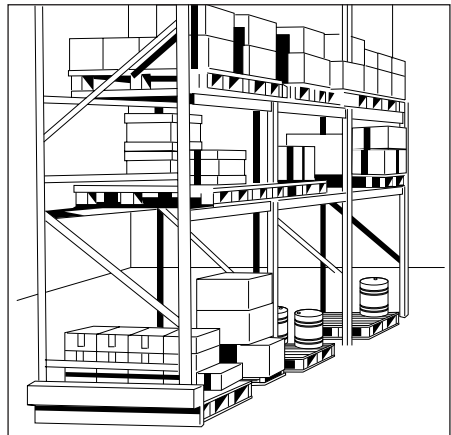

What to remember when mounting bearings

Rolling bearings are reliable machine elements with long lives, provided they are properly mounted and maintained. Proper mounting calls for experience as well as care, cleanliness and accuracy, and the right tools.

If contaminants are allowed to enter the bearing when it is being mounted, even the most efficient seals and lubricants will not prevent premature bearing failure. This can be avoided if a few simple recommendations are followed.

Where to mount

Mounting should, where possible, be conducted on a suitable workbench in dry and dust-free surroundings. The bearing should never be exposed to contaminants such as metal filings, swarf, sand or corrosive liquids. Only in exceptional cases should bearings be mounted outside closed rooms.

If it is not possible to move complete machines to a suitable workplace, then the part(s) of machines with bearings should be brought to a workshop where mounting can be carried out under proper conditions.

Preparations for mounting

Not only the bearing but also the shaft, housing and other components of the bearing ar-

range must be clean. All parts, including the seals, should be checked. Any burrs should be removed and the bearing seatings on the shaft and in the housing should be cleaned and any damaged seals replaced. The seatings should be lightly oiled to prevent damage during mounting.

Where repairs are concerned, the whole machine should be cleaned, especially where bearings are to be mounted.

New bearings

SKF bearings in their original packages are well protected against corrosion and should only be unpacked just before they are to be mounted (fig 1). The rust inhibiting medium with which the bearings are coated need not be removed, except on the outside diameter and in the bore. These surfaces should be wiped with a cloth which has been dipped in a petroleum solvent and should be dried using a clean lint-free cloth.

Bearings from damaged packages should be treated as used bearings.

Used bearings

Used bearings must be carefully cleaned before being remounted. Cleaning may be done cold or hot.

For cold cleaning, the bearing is dipped in a petroleum solvent or similar liquid and cleaned using a brush (fig 2). During washing, the bearing rings should be turned so

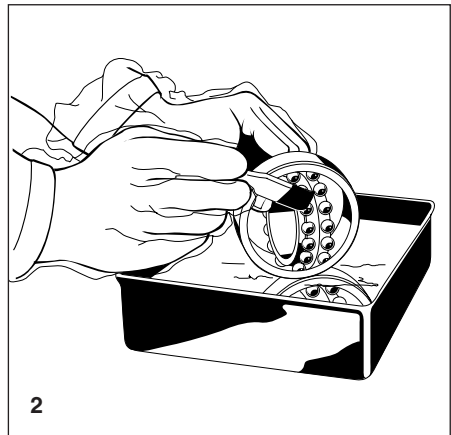
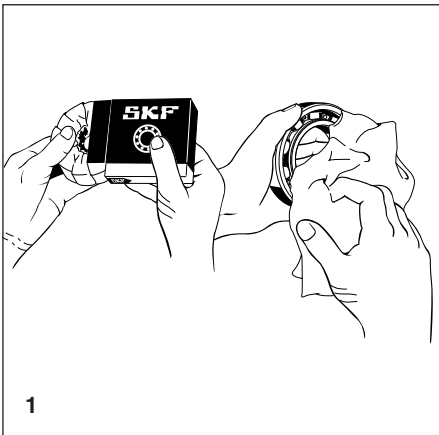

that all surfaces are cleaned. Separate solvent baths should be used for washing and rinsing. The bearings should be protected against contamination as they are drying off. If compressed air is used to dry the bearings, care should be taken to see that the bearings do not rotate. As soon as the bearing is dry it must be protected against corrosion, e.g. with LHPT 48.

For hot cleaning, a thin machine oil which has been heated to approximately 120 °C can be used. For safety reasons, the oil should have a flash point above 250 °C. Again separate baths should be used for washing and rinsing. The oil film which remains on the bearing after washing provides temporary protection against corrosion.

Very dirty bearings or those covered with tough, hardened lubricant are usually in such poor condition that cleaning is not worthwhile. It is generally more economic to replace them by new bearings. This also applies to bearings with seals at both sides, which cannot be cleaned and inspected without first removing the seals.

NB.

Whenever possible, protective gloves should be worn as frequent skin contact with petroleum products can cause allergies. Hot oil should be used with proper care because of the danger of fire.

Mounting on the shaft

The SKF tool kit TMFT 33 can be used to mount small bearings quickly, precisely and reliably. It is also possible to make mounting dollies or use lengths of piping for small bearings. The tools should be applied to the inner ring. The bearing should never be hit directly with a hammer (fig 3).

If a mechanical or hydraulic press is available, this may be used to mount small or medium-sized bearings. A sleeve or ring should be placed between the bearing and the press.

Medium and large-sized bearings are easier to mount if they are first heated to approximately 80 °C above room temperature. The SKF induction heaters TIH, see page 27, are particularly suitable for heating bearings. After heating, the bearing should quickly be pushed home on its seating and held in position until it has cooled (fig 4). Protective gloves should be used when handling hot bearings.

Small and medium-sized bearings with a tapered bore can be driven up on their tapered seatings using a shaft (lock) nut and a hook or impact spanner. For larger bearings it is recommended that a hydraulic nut be used, and for really large bearings the SKF oil injection method should be applied. This method requires the presence of oil ducts and distributor grooves in the shaft seating.

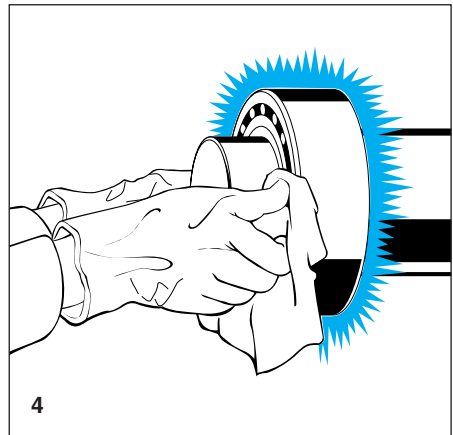
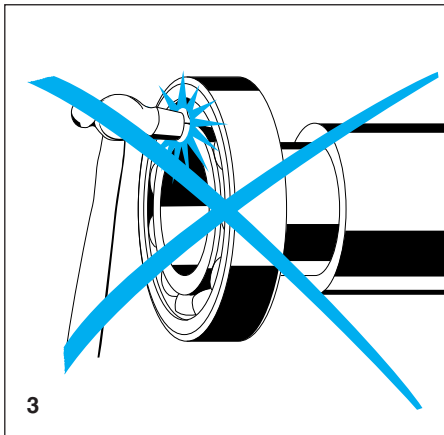

Recommendations and advice

Mounting in the housing

The SKF tool kit TMFT 33 can also be used to mount small bearings in their housings (fig 5) or mounting dollies or lengths of piping can be used. The tools should be applied to the outer ring of the bearing. Never apply hammer blows directly to a bearing. A mechanical or hydraulic press can also be used.

In order to mount bearings, particularly larger bearings, in their housings it is often necessary to heat the housing. Generally, the housing need only be slightly heated, e.g. using an electric light bulb (fig 6).

Mounting cylindrical roller bearings

Generally the bearing rings of cylindrical roller bearings are mounted separately. After oiling or greasing the rollers, the free ring and the ring with cage and roller assembly are joined (fig 7). The shaft or housing should be slowly turned as this is being done. Special care should be taken that the inner and outer rings do not skew. A mounting sleeve is useful here.

Mounting angular contact ball bearings and taper roller bearings

Mounting angular contact ball bearings and taper roller bearings may present difficulties. In many cases the bearing arrangement must be adjusted to a given clearance or preload. If instructions did not come with the machine, the machine builder should be contacted for advice.

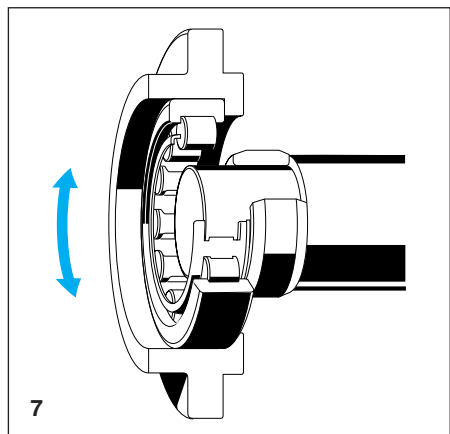
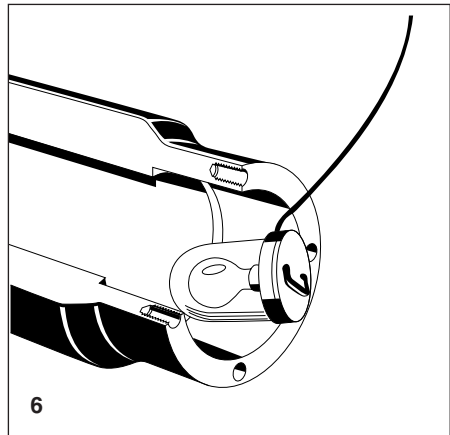
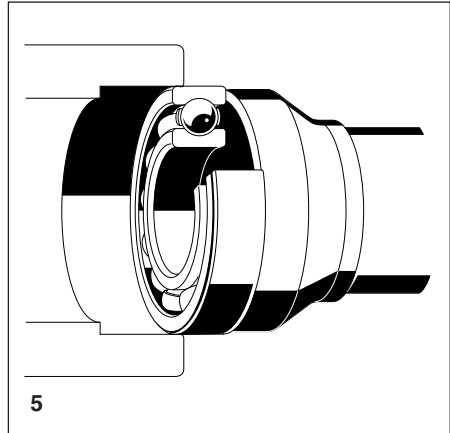

Mounting bearings on adapter sleeves

The adapter sleeve should be pushed on to the shaft to a pre-marked position (fig 8). This is relatively easy as the slot widens. The bearing is then positioned on the sleeve, the nut screwed on and the bearing pressed up the sleeve by tightening the lock nut. Remove the lock nut, insert the locking washer and replace the nut. Tighten it securely and bend down a tab of the washer to lock the nut (fig 9).

SKF hook and impact spanners can be used to tighten the nut, or the SKF spanner set TMHN 7 is also available, see page 25.

Bearings having a bore diameter of 50 mm and above can be easily and reliably mounted using an SKF hydraulic nut, see page 26.

Mounting bearings on withdrawal sleeves

The withdrawal sleeve should be positioned between the bearing and the shaft seating and then be pressed into the tapered bore of the bearing. With small bearings this can be achieved using a hammer and a mounting dolly. If the shaft is threaded, larger bearings can be much more easily installed using a lock nut or a hydraulic nut (fig 10). Here, too, the use of the SKF oil injection method considerably reduces the force required for mounting.

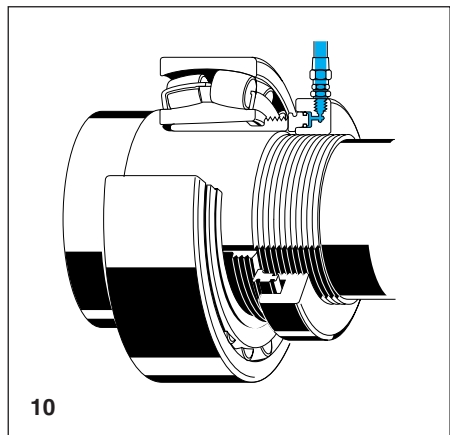
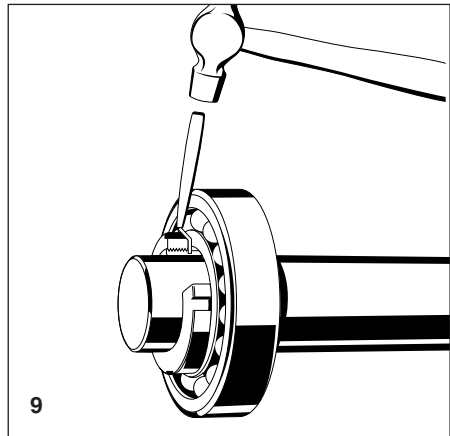
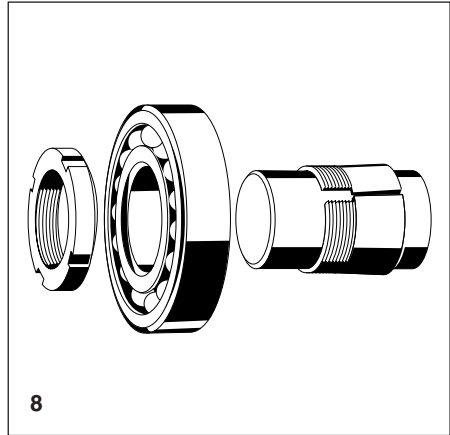

Bearing damage caused by faulty mounting

When the necessary experience or the proper tools are not available, mounting can often lead to premature bearing failure as illustrated by the following three examples.

The flaking (fig 11) in the outer ring raceway was caused by deformation of the ring resulting from, for example, out-of-round (ovality) of the housing seating. Such deformation often occurs where split bearing housings are used.

The damage shown in fig 12 is caused by axial clamping, which may have arisen because of an insufficiently wide seating in the housing. This would mean, for example, that the bearing could not be axially displaced in the housing if the shaft were to expand as temperatures increased.

If a bearing, which is to have an interference fit on the shaft, is pushed along the shaft by blows to the outer ring, the damage shown in fig 13 can result. The same damage could also be caused by blows to a shaft which is not properly supported.

Test run

After mounting has been completed, lubricant should be applied to the bearing and a test made to see that the bearing performs well under the operating conditions. Instructions are given on page 28. During, or immediately after the test run, the performance of the seals and any lubrication equipment should be checked, and with oil bath lubrication, the oil level should also be checked.

The test run should be made under partial load and, where there is to be a wide range of speeds in operation, at low to moderate speed. Under no circumstances should bearings be started up after mounting before the load is applied, or be allowed to accelerate without load.

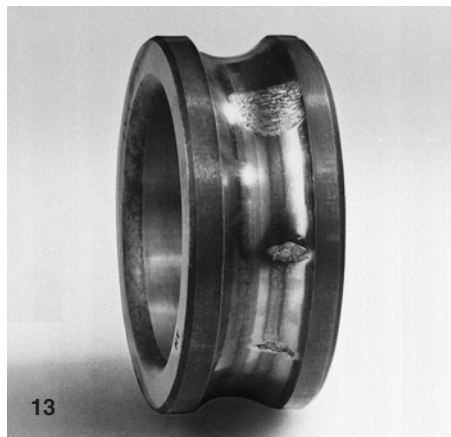
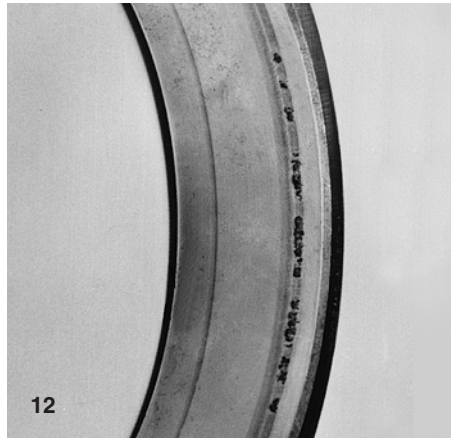
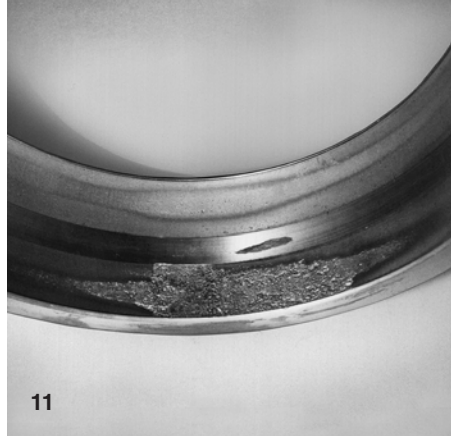

The tools to use for mounting

SKF mounting tools are right for the job. The SKF trademark is a guarantee that the tool is suitable for its purpose and is a high-quality product. The wide SKF range of tools and equipment for use with bearings enables the most efficient method to be used. The proper tool or equipment for any bearing type or size, and any type of bearing location method will always be available so that there is considerable freedom of choice.

Mechanical tools

- Bearing mounting tool kit TMFT 33 (fig 14) for bearings with bore diameters from 10 to 50 mm and outside diameters from 26 to 110 mm. Includes recoilless hammer with rubber covered fibre glass handle.
- Spanner set TMHN 7 (fig 15) for lock nuts and adapter sleeves of sizes 5 to 11 inclusive.
- HN hook spanners (fig 16), for all nuts and adapter sleeves up to and including size 40.
- Impact spanners, series 7189(00) (fig 17), for all nuts and adapter sleeves from size 24.

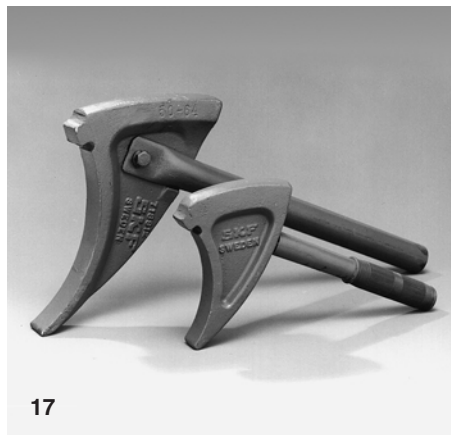
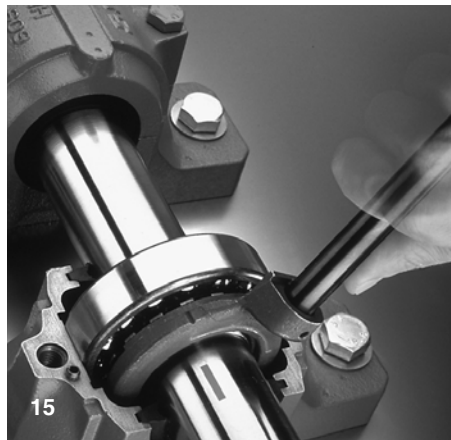

Recommendations and advice

Hydraulic tools

- HMV hydraulic nuts (fig 18) for threads from 50 mm diameter.
- Hand-operated oil pumps 728619 and 729124 (fig 19) for use with hydraulic nuts and the SKF oil injection method.
- Hydraulic tool kit 729101 B (fig 20) for the oil injection method.
- Pneumatically operated oil pump THAP (fig 21) for large volumes of oil.
- Mounting fluids LHM 300 and LHDF 900 as pressure media for hydraulic nuts and the oil injection method.
- Accessories for high pressure applications, including piping, connection and valve nipples, extension leads and pressure gauges.

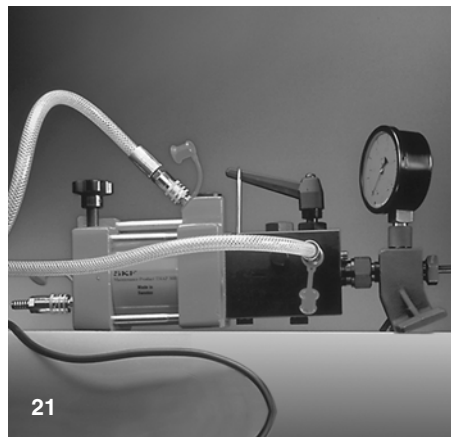
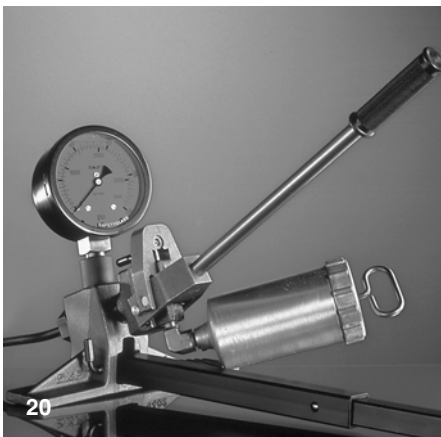
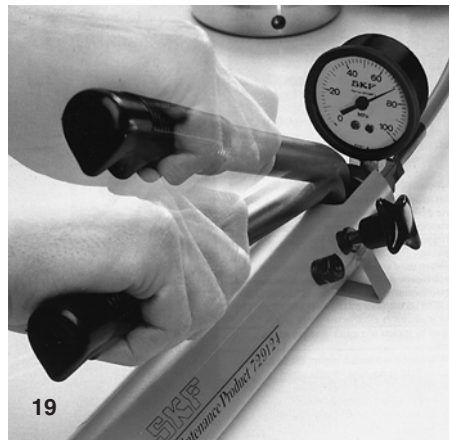
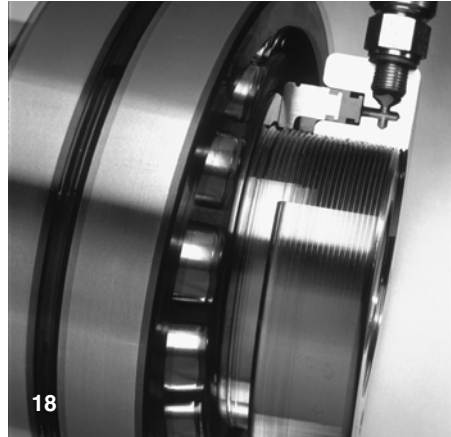

Heaters

- Electric hotplate 729659 B (fig 22) for small bearings and machine components.
- TIH induction heaters (fig 23) for small and medium-sized bearings.
- EAZ electric withdrawal tools (fig 24).
- Heating rings for cylindrical roller bearing inner rings (fig 25).

Full details of the tools and heaters mentioned above will be found in the brochure MP 236 “The Tools for Trouble-Free Operation” which also provides information on SKF condition monitoring equipment for bearings and machines.

The oil injection method is described in the SKF brochure PI 303. Both these publications are available on request.

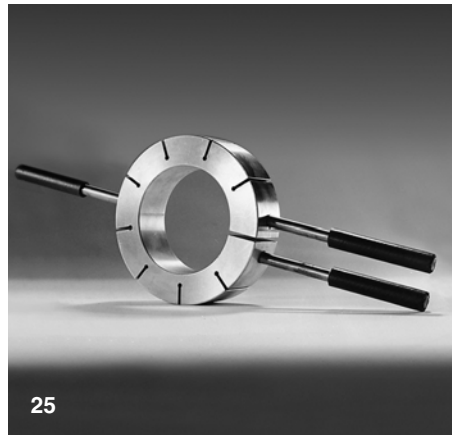
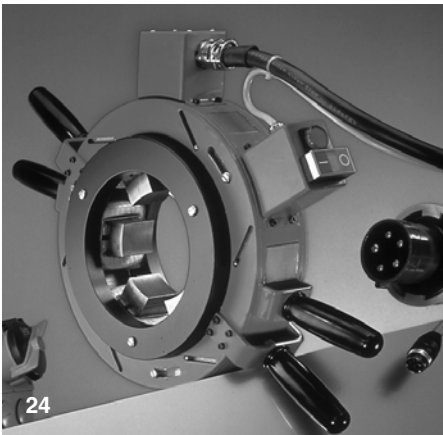

How to maintain correctly

Although rolling bearings are “predictable” machine elements and have long service lives, they should, in common with other machine elements, be checked from time to time. How often they have to be checked depends on the operating conditions.

Checking bearings in operation

In preventive maintenance, condition monitoring is becoming increasingly important. If incipient bearing damage is detected at an early stage, the bearings can be replaced at the next planned maintenance of the machine and unscheduled stoppages because of bearing damage are avoided. SKF has a wide range of equipment and associated software for the condition monitoring of bearing arrangements, complete machines and plants.

So far, in practice, the condition of very few machines is monitored using modern equipment. Maintenance engineers must, therefore, still rely on recognising the “alarm signals” sent out by the bearings which can either be heard, felt, or seen.

Listening

A widespread method of monitoring bearing arrangements is to listen to the running noise of the bearings. This may be achieved using

the SKF electronic stethoscope TMST 2 (fig 1) which can identify and locate the source of unusual noise. But running noise can also be checked without electronics. A simple wooden stick can be used. By placing an ear at one end and applying the stick to the housing as close as possible to the bearing, the running noise can be heard. An even quiet “purring” noise will be heard when there is nothing wrong, but if the bearing is damaged the noise will be a loud, generally irregular “knocking”.

Feeling

The temperature at the bearing position can be measured using the SKF digital ThermoPen TMTP 1 or simply by placing a hand on the bearing housing (fig 2). Unusually high temperatures or a sudden rise in temperature without any change in the operating conditions are sure signs that something is wrong. Exactly what is wrong, whether it is lubricant starvation or bearing damage, must then be ascertained and rectified.

NB.

Be careful when checking temperature by hand to avoid being burnt – a very slight touch or “near” touch of a finger tip should indicate whether it is safe to feel or not.

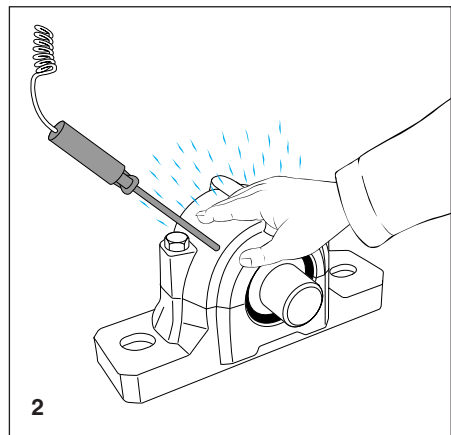
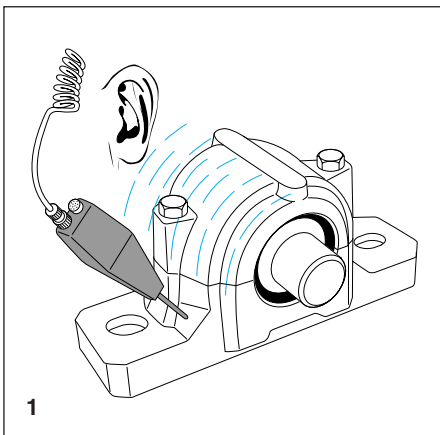

Looking

Visual inspection (fig 3) can be used to check the condition of seals, screw plugs, housing joints etc. and also lubrication (sight glass for oil bath level). If continuous lubrication is employed, it is necessary to check that sufficient lubricant is available in the system and that the proper quantity of lubricant is actually supplied.

The lubricant itself should also be checked. A small quantity should be removed and compared with the unused product. If the lubricant has become discoloured, this usually indicates ageing of the lubricant and if it is dark in colour this is a sign of contamination. Aged oil will also flow less easily. If the oil is cloudy this generally means that it contains water. In all cases it is advisable to completely replace the lubricant, and it is also recommended that the seals be replaced at the same time.

Otherwise, the maintenance instructions from the machine builder should be followed for grease lubrication, and the appropriate grease or corresponding SKF grease, see page 33, should be used for relubrication. With oil lubrication, the oil level should be checked and the correct oil used for filling up. More information on lubrication will be found on page 30.

Checking bearings when they are standing still

This type of inspection should preferably be carried out during a planned stoppage of the machine, or when the machine is to be disassembled, e.g. for repairs. Some time before the machine is stopped it is advisable to check that replacement bearings and replacement seals are available and any drawings needed are also ready.

When dismantling the bearings, the recommendations given on page 34 should be followed. Recommendations for re-mounting are given on page 20.

Maintenance report

It is advisable to record all the data relevant to a particular bearing position in a maintenance report. This should contain, for example, the condition of the bearing arrangement, the lubricant to be used, the relubrication intervals, the date of the last relubrication etc. Drawings of the bearing arrangement or the machine and a list of spare parts should also be included. This type of report gives a good picture of the situation and allows future maintenance work to be well planned.

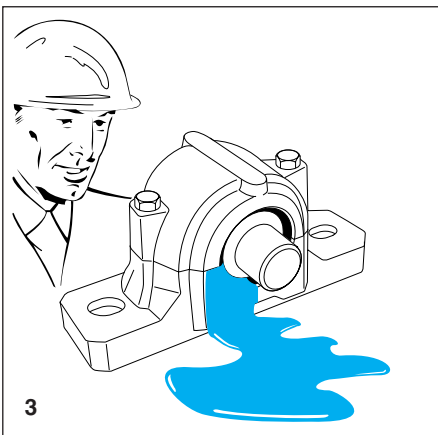

How to lubricate properly

The purpose of the lubricant is to prevent direct contact occurring between the rolling elements, raceways and cage(s), and thus to keep friction and wear at a minimum. Lubricant should also protect the bearing surfaces against corrosion. In addition, grease is often used to enhance sealing, and oil to remove heat from the bearing position (circulating oil).

The choice of the particular lubricant and application method to be used for a given application depends on the operating conditions, but may also be dictated by the lubrication requirements of neighbouring components. Environmental factors such as dust, water spray, condensation or aggressive media and the orientation of the shaft (horizontal or vertical) also play a part. The lubricant must also be compatible with the cage material of the bearing and any seals. More details will be found in the adjacent table.

Grease lubrication

Open bearings, i.e. without shields or seals, must be greased on mounting. When and how this should be done depends on the type of bearing and on the design of the housing.

The rings, with or without cage and roller assembly, of separable bearings, e.g. cylindrical roller bearings or taper roller bearings, should be greased as they are mounted.

After mounting the first ring, the space behind it should be greased (fig 1). The raceways of the separate rings should be lightly greased to prevent the raceway becoming damaged when the bearing is “assembled”. After the ring with roller and cage assembly has been mounted, the free space between the rollers should be filled with grease.

Non-separable bearings should be filled with grease from both sides. After self-aligning bearings have been mounted on the shaft, the outer ring can be swivelled out and grease be introduced into the space between the two sets of balls or rollers. Only if it is impossible to evenly distribute grease in a bearing once it has been mounted should it be greased before mounting.

For split bearing housings (plummer blocks), the bearing is first mounted on the

shaft and filled with grease from both sides (fig 2). Then the bearing with the shaft is lowered into the housing and the prescribed amount of grease put into the free space in the housing.

For one-piece housings and non-separable bearings, the free space behind the bearing should first be filled with grease. After fitting the bearing (normally ungreased), the bearing should be greased from the open side of the housing. Greasing bearings with annular groove and/or lubrication holes in the outer or inner ring (or both) is particularly easy if appropriate means of lubricant supply are provided in the housing and/or shaft. Finally, the free space in front of the bearing should be filled with grease.

Permissible operating temperatures for cages of glass fibre reinforced polyamide 6,6 with various bearing lubricants

Lubricant	Permissible operating temperature ¹⁾
Mineral oils	
Oil without EP additives e.g. machine oils, hydraulic oils	120 °C
EP oils e.g. industrial and automotive gearbox oils	110 °C
EP oils e.g. rear axle and differential gear oils (automotive), hypoid gear oils	100 °C
Synthetic oils	
Polyglycols, poly- α -olefins	120 °C
Diesters, silicones	110 °C
Greases	
Lithium base ²⁾ , polyurea, bentonite, calcium complex	120 °C

¹⁾ Measured on the outside surface of the outer ring

²⁾ For sodium and calcium base grease as well as bearing greases with EP additives, the maximum temperature for the polyamide cage is the same as the maximum temperature for the grease

Relubrication

The maintenance instructions issued by the machine builders should be followed when relubricating the bearing positions. Before relubrication, make sure that any grease nipples are clean. If there are no grease nipples on the housing, the housing cap (upper half) or side cover should be removed. The used grease is then taken out and replaced by fresh grease of the same type or by an equivalent SKF grease, see page 33. SKF can also supply hand-operated grease guns (fig 3) which are useful when relubricating via a grease nipple. Full details are available on request.

Grease quantity

Generally, the used grease in the bearing should be replaced by fresh grease. The quantity required depends on the bearing size. If no instructions are available, the requisite quantity can be obtained using the following rule of thumb.

$$G = 0,005 D B$$

where

G = grease quantity, g

D = bearing outside diameter, mm

B = total bearing width or height, mm

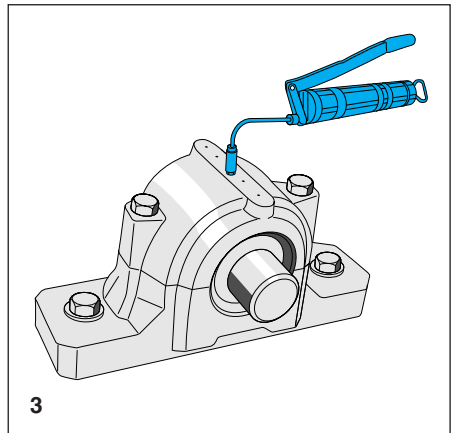
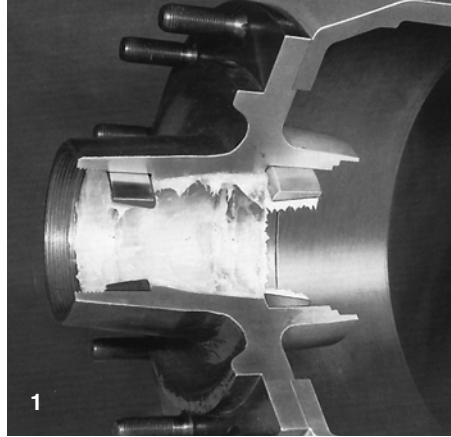

Recommendations and advice

Oil lubrication

Care should be taken when mounting bearings which are to be lubricated with oil to see that the raceways and rolling elements are oiled and also that after mounting, but before oil is supplied (fig 4), the bearings are not rotated at speed, and above all are not rotated under load.

Oil change

How often the oil must be changed depends mainly on the operating conditions and the oil quantity. Generally the machine builder will specify suitable intervals.

If the oil is cloudy, discoloured or does not flow easily, it will contain water and other contaminants. In such cases, the oil should be completely replaced, and preferably the bearing position should be washed out, or flushed with clean oil. The correct oil must

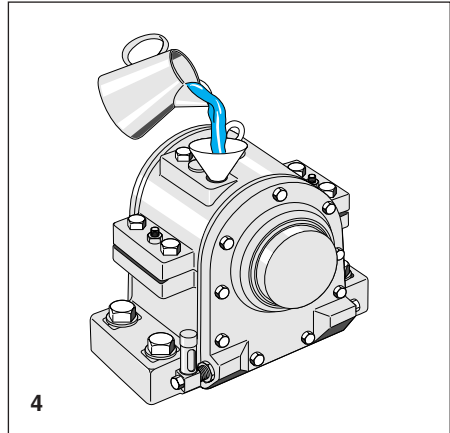

SKF lubricating greases

Properties Description Suitability	Lubricating greases (Designations)					
	LGMT 2	LGMT 3	LGEP 2	LGWM 1	LGMB 2	LGHB 2
Thickener	Lithium soap	Lithium soap	Lithium soap	Lithium soap	Lithium/calcium soap	Calcium sulphonate complex
Base oil	Mineral oil	Mineral oil	Mineral oil	Mineral oil	Mineral oil	Mineral oil
Temperature range, °C	-30/+120	-30/+120	-20/+110	-30/+110	-20/+120	-20/+150
Kinematic viscosity, mm ² /s, of base oil at 40 °C	110	120	190	200	780	420
Description	Multi-purpose industrial and automotive grease	Multi-purpose industrial and automotive grease	Extreme pressure grease	Extreme pressure, low temperature grease	Highly viscous extreme pressure grease	Highly viscous high temperature extreme pressure grease
Suitable for:						
very high speeds	☐	☐	☐	☐	—	☐
very slow oscillation	☐	☐	☐	☐	■	■
low friction	■	☐	☐	☐	—	☐
strong vibrations shock loads	☐	☐	■	—	■	☐
heavy loads	☐	☐	■	■	■	■
preventing corrosion	☐	☐	■	■	■	■
resisting water	☐	☐	■	■	■	■
	■ Recommended	☐ Suitable	— Unsuitable	When no symbol is given, the grease		

be used and filled to the correct level. It is also necessary to check that the ventilation holes are not blocked.

SKF lubricating greases

The effect of contamination on bearing life is known. This is the reason why SKF is active, not only in sealing technology, but also in the development of lubricating greases for bearings. This has resulted in the 13 SKF greases shown in the matrix below and which cover a wide range of applications.

The benefits of SKF greases include

- the high and consistent quality which is continuously checked,
- the full range of multi-purpose and special greases, and
- the worldwide availability via the SKF sales network.

Full details of SKF greases will be found in the brochure MP 318 “SKF Bearing Lubricants” which is available on request.

LGEM 2	LGEV 2	LGLT 2	LGLC 2	LGHQ 3	LGWA 2	LGFC 2
Lithium soap	Lithium/calcium soap	Lithium soap	Calcium complex soap	Lithium complex soap	Lithium complex soap	Calcium soap
Mineral oil	Mineral oil	Diester oil	Ester/mineral oil	Mineral oil	Mineral oil	Vegetable oil
-20/+120	-20/+120	-55/+110	-40/+120	-20/+150	-30/+140	-20/+80
510	1000	15	23	110	185	40
Highly viscous grease with solid lubricant additives	Extremely viscous grease with solid lubricant additives	Low temperature grease	Low temperature grease for high speed operation	High temperature grease	Grease with extended temperature range	Grease suitable for use in food processing equipment
—	—	■	■		□	
■	■	—	—			□
—	—	■	■	□	□	□
■	■			□		□
■	■	—	□	□	■	□
□	■	□	■	□	■	■
□	■	■	■	□	■	■

may be suitable under certain conditions

What to remember when dismantling bearings

Remember: never remove an undamaged bearing unless it is absolutely necessary.

If it is necessary to dismantle a bearing then the same care is required as when mounting. This also applies to damaged bearings which are to be inspected after dismantling in order to deduce the cause of the damage.

If the bearing is to be re-used, it is recommended that its position should be marked, e.g. what part of the bearing is “top”, “front” etc.

Interference fit on the shaft

The shaft should first be properly supported so that the bearing will not be damaged by the force required to dismantle it.

Small and medium-sized bearings can be removed by applying a puller to the inner ring. The TMBS withdrawal kits (fig 1) from SKF have been specially developed for this. A hydraulic spindle will help.

Only in cases where it is impossible to apply a puller to the inner ring, is it permitted to withdraw the bearing via the outer ring. It is very important during this operation to continuously turn the outer ring as it is being withdrawn, to prevent the bearing components from being damaged by the dismantling force (fig 2). The use of self-centring pullers also reduces the risk of damage. SKF offers a wide range of withdrawal tools, with or without hydraulic support.

The SKF oil injection method considerably eases the removal of large bearings and bearings with a tapered bore. However, oil supply ducts and grooves must be in place (fig 3).

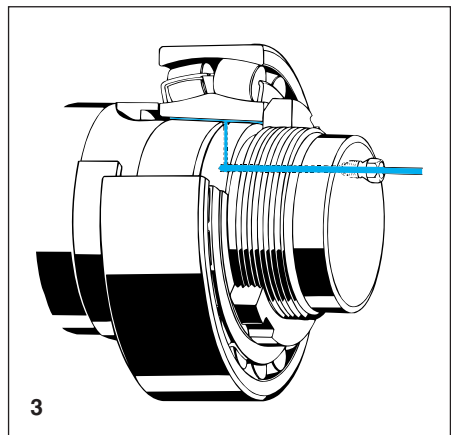
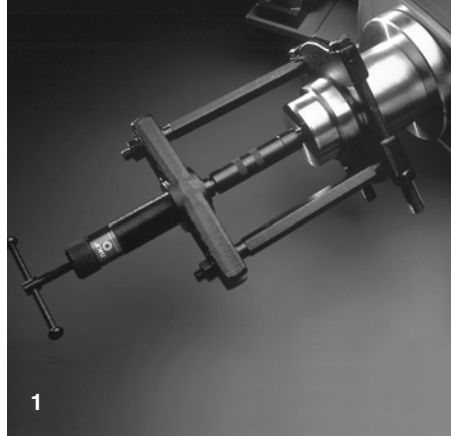

Interference fit in the housing

In many cases it is possible to press the bearing out of its housing using a press or mounting dolly and hammer applied to the outer ring. The SKF mounting kit TMFT 33 can also be used to dismount small bearings, see page 25.

Where the bearing abuts a fixed shoulder in the housing, a drift and hammer can be used. Small deep groove ball bearings can be quickly and easily removed using the SKF tool kit TMSC 6 (fig 4).

Interference fits in the housing and on the shaft

In such cases, when the bearing is not separable, it is preferable to press the bearing out of the housing together with the shaft. It is, of course, also possible to withdraw the bearing and housing together from the shaft.

The SKF bearing puller kit TMBP 7 can be used for small deep groove ball bearings (fig 5). The tool kit TMPB 20 can be used for larger deep groove and angular contact ball bearings. However, this should only be used to dismount bearings which are not to be re-used, as the cage will be destroyed.

Bearings on adapter sleeves

The work should always start with marking the position of the sleeve on the shaft. Then the tab of the locking washer which holds the nut should be bent upright and the nut should be unscrewed a few turns. A suitable drift (fig 6) should be applied to the bearing inner ring at the large diameter side of the sleeve and a hammer used to loosen the grip of the bearing on the sleeve. The blows should be applied evenly around the circumference. Finally, the nut should be completely unscrewed and the adapter sleeve removed from the shaft. This process is eased if the slot is widened, e.g. using a screwdriver.

If bearings on adapter sleeves are mounted against a shoulder, then dismounting will be much easier, particularly if an SKF hydraulic nut can be used.

Details of the withdrawal and dismounting tools mentioned in the above will be found in the publication MP 254 "SKF Bearing Pullers".

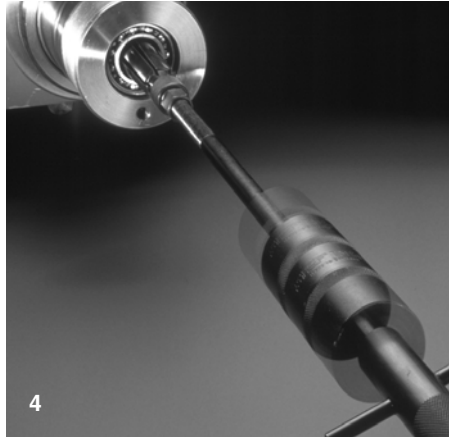

4



5

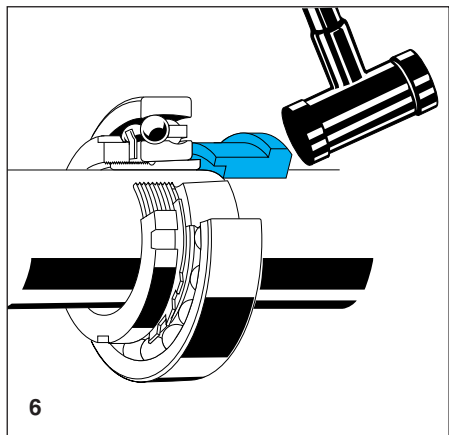

6

What to remember about sealing

Seals are those components of a bearing arrangement which have to retain the lubricant at the bearing position and to prevent contaminants from entering (fig 1). They should therefore be given special attention when mounting, maintaining and repairing.

Mounting

When mounting radial shaft seals (oil seals, garter seals) the following points should be remembered:

- the housing bore should be chamfered and smoothed;
- the seal should be coated with oil or grease before mounting;
- the seal must not be allowed to skew or tilt as it is being mounted;
- the counterface on the shaft should be free of bruises, scratches, cracks, rust or bumps;
- the edge(s) on the shaft over which the seal is to be passed should be chamfered and smoothed.

Maintenance

Radial shaft seals should always be inspected during routine maintenance as well as when an unplanned stoppage occurs. As soon as they show any signs of wear or leakage, they should be replaced. Signs of wear can be recognised by the seal making a track on the shaft and leakage by traces of lubricant on the wrong side of the seal. The lubricant itself will also indicate whether the seal is performing properly. If the lubricant has darkened in colour, is cloudy, or flows less easily, then this is a sign that one or more seals are worn or otherwise defect.

Replacement

During repair work, the seals should always be replaced. The sealing edge (lip) of the seal should not be allowed to run on the track made by the old seal. A simple way of achieving this is to use a CR Speedi-Sleeve (fig 2). This is pushed over the damaged counterface, making the shaft as good as new in a

matter of minutes, and at a fraction of the cost of other methods (fig 3).

CR Speedi-Sleeves are extremely thin-walled and allow the use of the same size of seal as the original. They are made of high-grade stainless steel. The counterface is machined without directionality and is often better than the original shaft surface.

Seal replacement should not just consist of replacing a seal with a new one of the same design. Efforts should be made to find out why the seal needed replacement, for example,

- was it wrongly installed,
- has a different lubricant been used, or are the additives different, or
- is the seal material unsuitable?

If operating conditions are exceptional, or if contamination of the environment has increased, it may be to advantage to generally upgrade the sealing. One way is to use a seal made of more wear-resistant material, or a second seal can be placed in front of the seal of the original design, to protect it from contaminants.

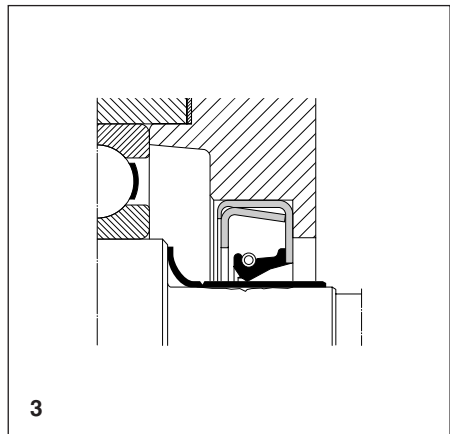
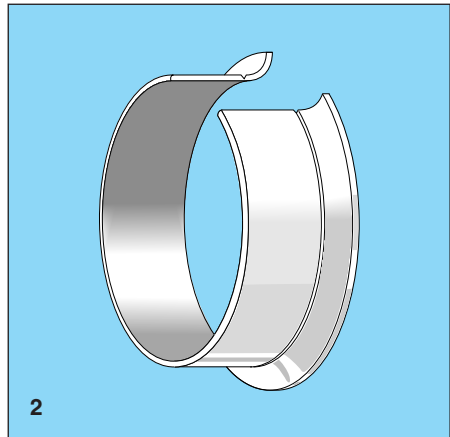
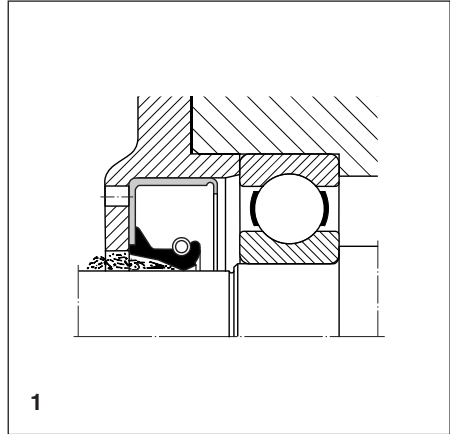

Product data

Deep groove ball bearings.....	page 40
Self-aligning ball bearings	page 50
Angular contact ball bearings	page 55
Four-point contact ball bearings.....	page 62
Single row cylindrical roller bearings	page 64
Full complement cylindrical roller bearings	page 71
Drawn cup needle roller bearings	page 74
Needle roller bearings	page 77
Spherical roller bearings	page 83
Taper roller bearings.....	page 90
Thrust ball bearings	page 99
Cylindrical roller thrust bearings	page 104
Needle roller thrust bearings.....	page 106
Spherical roller thrust bearings	page 108
Combined needle roller bearings.....	page 110
Precision bearings	page 114
Precision single row angular contact ball bearings	page 114
Precision double row cylindrical roller bearings	page 116
Precision double direction angular contact thrust ball bearings.....	page 120
Track runner bearings	page 122
Y-bearings	page 130
Y-bearing units	page 135
Pop Release® plummer block units.....	page 148
SNH plummer block housings	page 150
Adapter and withdrawal sleeves	page 158
Spherical plain bearings.....	page 165
Rod ends.....	page 171
GLYCODUR® plain bearings	page 179

Deep groove ball bearings

Deep groove ball bearings are simple in construction as well as easy to operate and maintain. They can run at high speeds and can support both radial and axial loads.

SKF deep groove ball bearings are available in single and double row designs. Their special benefits are

- robust quality,
- high load carrying capacity, and
- low friction and quiet operation.

A wide variety of types and sizes can be supplied; standard bearings for conventional as well as unconventional applications. The cost/performance ratio for deep groove ball bearings is excellent.

Range

Open (unsealed) bearings which are also available in sealed versions may, for reasons of manufacture, have seal recesses in the outer ring.

Bearings with shields or seals at both sides are filled with a lithium base grease. This has good rust inhibiting properties and

can be used at temperatures between -30 and $+110$ °C. The sealed bearings are lubricated for life and maintenance-free.

In addition to the bearings listed in the tables, the SKF range also includes

- bearings with snap ring groove in outer ring,
- bearings in inch sizes,
- “max” bearings with filling slot,
- conveyor roller bearings and
- bearings for high temperatures.

Further information on these bearings can be obtained from any SKF authorised distributor.

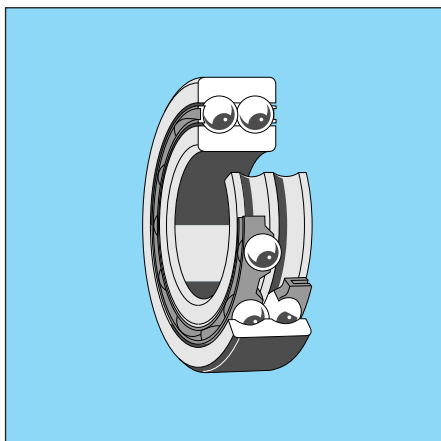
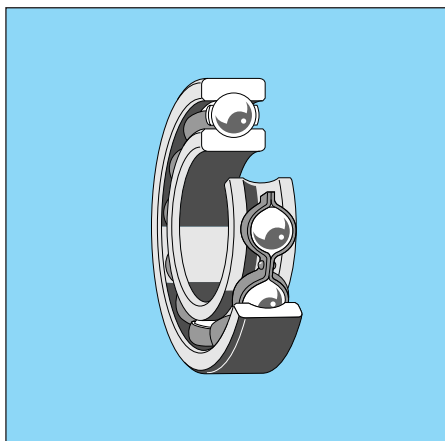

Dimensions

The boundary dimensions of the bearings listed in the tables are in accordance with ISO 15-1981.

Tolerances

SKF deep groove ball bearings are produced to Normal tolerances as standard. Some sizes are also available with increased accuracy to P6 or P5 specifications; please enquire. The tolerances conform to ISO 492:1994.

Internal clearance

SKF deep groove ball bearings have Normal radial internal clearance as standard. Many of the smaller sizes can also be supplied with smaller or larger clearance than Normal; please enquire. The clearance limits are as specified in ISO 5753:1991.

Cages

Depending on bearing series and size, SKF deep groove ball bearings incorporate

- a pressed steel cage (no suffix),
- a glass fibre reinforced polyamide 6,6 cage, or
- a machined brass cage.

Bearings with polyamide 6,6 cages can normally be used at temperatures up to +120 °C. For further information see page 30.

Supplementary designations

The supplementary designations which are frequently used for SKF deep groove ball bearings are explained in the following.

Prefix

W Bearing of stainless steel

Suffixes

A Modified internal geometry; double row bearing without filling slot

ATN9 A + TN9

C2 Radial internal clearance smaller than Normal

C3 Radial internal clearance greater than Normal

M Machined brass cage

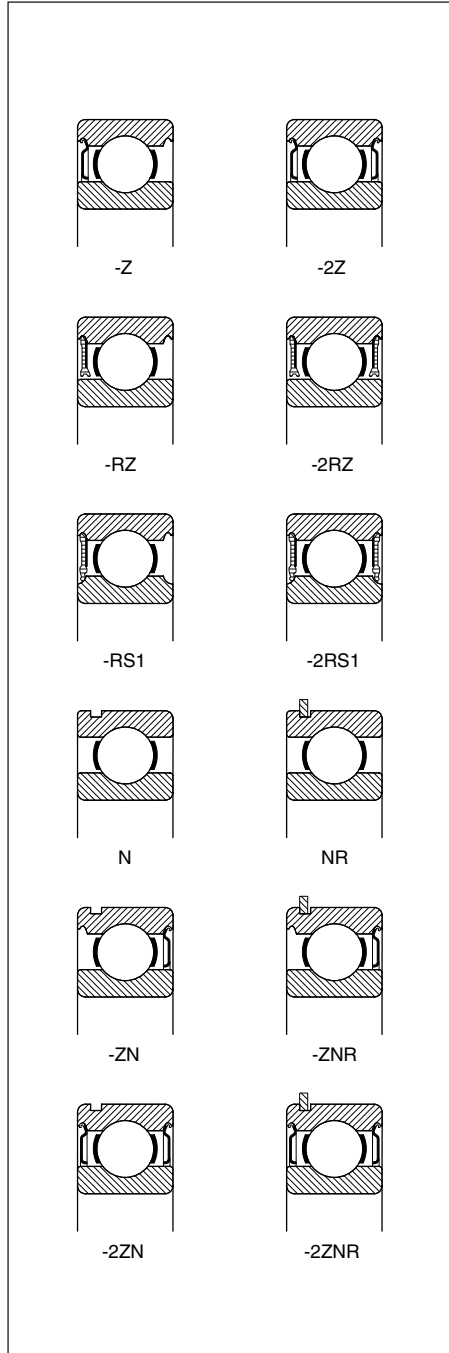

Deep groove ball bearings

MA	Machined brass cage, outer ring centred
N	Snap ring groove in outside diameter of outer ring
NR	Snap ring groove in outer ring, with snap ring
P5	Increased dimensional and running accuracy (better than P6) to ISO tolerance class 5
P6	Increased dimensional and running accuracy (better than Normal) to ISO tolerance class 6
P63	P6 + C3
-RS1	Synthetic rubber seal (rubbing seal) with sheet metal reinforcement at one side of bearing
-2RS1	RS1 seal at both sides of bearing
-RZ	Low-friction synthetic rubber seal with sheet steel reinforcement at one side of bearing
-2RZ	RZ seal at both sides of bearing
TN9	Injection moulded glass fibre reinforced polyamide 6,6 cage
Y	Pressed brass cage
-Z	Pressed steel shield (non-rubbing seal) at one side of bearing
-ZN	Z + N
-ZNR	Z + NR
-ZZ	Z shield at both sides of bearing
-2ZN	2Z + N
-2ZNR	2Z + NR

Deep groove ball bearings
single row
d 3–10 mm

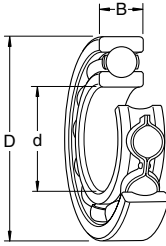

Dimensions			Basic load rating dynamic C	Mass kg	Designation	
d	D	B				
mm			kN	kg	–	
3	10	4	0,49	0,002	623	
	10	4	0,49	0,002	623-Z	
	10	4	0,49	0,002	623-2Z	
	10	4	0,49	0,002	623-2RS1	
4	9	2,5	0,54	0,001	618/4	
	9	3,5	0,54	0,001	628/4-2Z	
	9	3,5	0,45	0,001	W 628/4-2Z	
	11	4	0,65	0,002	619/4	
	11	4	0,65	0,002	619/4-2Z	
	11	4	0,61	0,002	W 619/4-2Z	
	13	5	0,98	0,003	624	
	13	5	0,98	0,003	624-Z	
	13	5	0,98	0,003	624-2Z	
	16	5	1,11	0,005	634	
	16	5	1,11	0,005	634-2Z	
	5	11	3	0,64	0,001	618/5
11		4	0,64	0,002	628/5-2Z	
11		4	0,54	0,002	W 628/5-2Z	
13		4	0,82	0,003	619/5	
13		4	0,82	0,003	619/5-2Z	
13		4	0,74	0,003	W 619/5-2Z	
16		5	1,11	0,005	625	
16		5	1,11	0,005	625-Z	
16		5	1,11	0,005	625-2Z	
16		5	1,11	0,005	625-2RS1	
19		6	2,21	0,009	635	
19		6	2,21	0,009	635-2Z	
6	13	3,5	0,88	0,002	618/6	
	13	5	0,88	0,003	628/6-2Z	
	13	5	0,74	0,003	W 628/6-2Z	
6	15	5	1,12	0,004	619/6	
	15	5	1,12	0,004	619/6-2Z	
	15	5	1,04	0,004	W 619/6-2Z	
	19	6	2,21	0,008	626	
	19	6	2,21	0,008	626-Z	
	19	6	2,21	0,008	626-2Z	
	19	6	2,21	0,008	626-2RZ	
	19	6	2,21	0,008	626-RS1	
	19	6	2,21	0,008	626-2RS1	
	7	14	3,5	0,96	0,002	618/7
		14	5	0,96	0,003	628/7-2Z
		14	5	0,81	0,003	W 628/7-2Z

Dimensions			Basic load rating dynamic C	Mass kg	Designation
d	D	B			
mm			kN	kg	–
7	17	5	1,35	0,005	619/7
	(cont.)	5	1,35	0,005	619/7-2Z
	17	5	1,12	0,005	W 619/7-2Z
	19	6	2,21	0,008	607
	19	6	2,21	0,008	607-Z
	19	6	2,21	0,008	607-2Z
	19	6	2,21	0,008	607-RS1
	19	6	2,21	0,008	607-2RS1
	22	7	3,25	0,013	627
	22	7	3,25	0,013	627-Z
	22	7	3,25	0,013	627-2Z
	22	7	3,25	0,012	627-2RS1
8	16	4	1,33	0,003	618/8
	16	5	1,33	0,004	628/8-2Z
	16	5	1,12	0,004	W 628/8-2Z
	19	6	1,72	0,007	619/8
	19	6	1,72	0,007	619/8-2Z
	19	6	1,59	0,007	W 619/8-2Z
	22	7	3,25	0,012	608
	22	7	3,25	0,012	608-Z
	22	7	3,25	0,012	608-2Z
	22	7	3,25	0,012	608-2RZ
	22	7	3,25	0,012	608-RS1
	22	7	3,25	0,012	608-2RS1
	22	11	3,25	0,016	630/8-2RS1
9	17	4	1,43	0,003	618/9
	17	5	1,43	0,004	628/9-2Z
	17	5	1,19	0,004	W 628/9-2Z
	20	6	1,90	0,008	619/9
	20	6	1,90	0,008	619/9-2Z
	24	7	3,71	0,014	609
	24	7	3,71	0,014	609-Z
	24	7	3,71	0,014	609-2Z
	24	7	3,71	0,014	609-RS1
	24	7	3,71	0,014	609-2RS1
	26	8	4,62	0,020	629
	26	8	4,62	0,020	629-Z
	26	8	4,62	0,020	629-2Z
	26	8	4,62	0,020	629-2RS1
10	19	5	1,38	0,006	61800
	19	5	1,38	0,006	61800-2Z
	19	5	1,38	0,006	61800-2RS1



Deep groove ball bearings
single row
d 20–40 mm

Dimensions					Designation	Dimensions					
d	D	B	Basic load rating dynamic C	Mass		d	D	B	Basic load rating dynamic C	Mass	Designation
mm			kN	kg	–	mm			kN	kg	–
20 (cont.)	42	8	6,89	0,050	16004	30 (cont.)	55	9	11,2	0,085	16006
	42	12	9,63	0,069	6004		55	13	13,3	0,12	6006
	42	12	9,63	0,069	6004-Z		55	13	13,3	0,12	6006-Z
	42	12	9,63	0,069	6004-2Z		55	13	13,3	0,12	6006-2Z
	42	12	9,63	0,069	6004-RS1		55	13	13,3	0,12	6006-RS1
	42	12	9,63	0,069	6004-2RS1		55	13	13,3	0,12	6006-2RS1
	42	16	9,63	0,086	63004-2RS1		55	19	13,3	0,16	63006-2RS1
	47	14	12,7	0,11	6204		62	16	19,5	0,20	6206
	47	14	12,7	0,11	6204-Z		62	16	19,5	0,20	6206-Z
	47	14	12,7	0,11	6204-2Z		62	16	19,5	0,20	6206-2Z
	47	14	12,7	0,11	6204-RS1		62	16	19,5	0,20	6206-RS1
	47	14	12,7	0,11	6204-2RS1		62	16	19,5	0,20	6206-2RS1
	47	18	12,7	0,13	62204-2RS1		62	20	19,5	0,24	62206-2RS1
	52	15	15,9	0,14	6304		72	19	28,1	0,35	6306
	52	15	15,9	0,14	6304-Z		72	19	28,1	0,35	6306-Z
	52	15	15,9	0,14	6304-2Z		72	19	28,1	0,35	6306-2Z
	52	15	15,9	0,14	6304-RS1		72	19	28,1	0,35	6306-RS1
	52	15	15,9	0,14	6304-2RS1		72	19	28,1	0,35	6306-2RS1
	52	21	15,9	0,20	62304-2RS1		72	27	28,1	0,48	62306-2RS1
	72	19	30,7	0,40	6404		90	23	43,6	0,74	6406
25	37	7	4,36	0,022	61805	35	47	7	4,75	0,030	61807
	37	7	4,36	0,022	61805-2RZ		47	7	4,75	0,030	61807-2RS1
	37	7	4,36	0,022	61805-2RS1		55	10	9,56	0,080	61907
	42	9	7,02	0,045	61905		55	10	9,56	0,080	61907-2RZ
	42	9	7,02	0,045	61905-2RZ		62	9	12,4	0,11	16007
	42	9	7,02	0,045	61905-2RS1		62	14	15,9	0,16	6007
	47	8	7,61	0,060	16005		62	14	15,9	0,16	6007-Z
	47	12	11,2	0,080	6005		62	14	15,9	0,16	6007-2Z
	47	12	11,2	0,080	6005-Z		62	14	15,9	0,16	6007-RS1
	47	12	11,2	0,080	6005-2Z		62	14	15,9	0,16	6007-2RS1
	47	12	11,2	0,080	6005-2ZNR		62	20	15,9	0,21	63007-2RS1
	47	12	11,2	0,080	6005-RS1		72	17	25,5	0,29	6207
	47	12	11,2	0,080	6005-2RS1		72	17	25,5	0,29	6207-Z
	47	16	11,2	0,10	63005-2RS1		72	17	25,5	0,29	6207-2Z
	52	15	14,0	0,13	6205		72	17	25,5	0,29	6207-RS1
	52	15	14,0	0,13	6205-Z		72	17	25,5	0,29	6207-2RS1
	52	15	14,0	0,13	6205-2Z		72	23	25,5	0,37	62207-2RS1
	52	15	14,0	0,13	6205-RS1		80	21	33,2	0,46	6307
	52	15	14,0	0,13	6205-2RS1		80	21	33,2	0,46	6307-Z
	52	18	14,0	0,15	62205-2RS1		80	21	33,2	0,46	6307-2Z
62	17	22,5	0,23	6305	80	21	33,2	0,46	6307-RS1		
62	17	22,5	0,23	6305-Z	80	21	33,2	0,46	6307-2RS1		
62	17	22,5	0,23	6305-2Z	80	31	33,2	0,66	62307-2RS1		
62	17	22,5	0,23	6305-RS1	80	31	33,2	0,66			
62	17	22,5	0,23	6305-2RS1	100	25	55,3	0,95	6407		
62	24	22,5	0,32	62305-2RS1							
80	21	35,8	0,53	6405	40	52	7	4,94	0,034	61808	
						52	7	4,94	0,034	61808-2RS1	
28	58	16	16,8	0,18		62/28	62	12	13,8	0,12	61908
	58	16	16,8	0,18		62/28-2RS1	62	12	13,8	0,12	61908-2RZ
30	42	7	4,49	0,027		61806	62	12	13,8	0,12	61908-2RS1
	42	7	4,49	0,027		61806-2RS1	68	9	13,3	0,13	16008
	47	9	7,28	0,051		61906	68	15	16,8	0,19	6008
	47	9	7,28	0,051		61906-2RZ	68	15	16,8	0,19	6008-Z
	47	9	7,28	0,051		61906-2RS1	68	15	16,8	0,19	6008-2Z
							68	15	16,8	0,19	6008-RS1
							68	15	16,8	0,19	6008-2RS1
							68	15	16,8	0,19	63008-2RS1
							68	21	16,8	0,26	



Deep groove ball bearings
single row
d 40–65 mm

Dimensions						Designation						
d	D	B	Basic load rating dynamic C	Mass		d	D	B	Basic load rating dynamic C	Mass		
mm			kN	kg	–	mm			kN	kg	–	
40 (cont.)	80	18	30,7	0,37	6208	50 (cont.)	110	27	61,8	1,05	6310	
	80	18	30,7	0,37	6208-Z		110	27	61,8	1,05	6310-Z	
	80	18	30,7	0,37	6208-2Z		110	27	61,8	1,05	6310-2Z	
	80	18	30,7	0,37	6208-RS1		110	27	61,8	1,05	6310-RS1	
	80	18	30,7	0,37	6208-2RS1		110	27	61,8	1,05	6310-2RS1	
	80	23	30,7	0,44	62208-2RS1		110	40	61,8	1,55	62310-2RS1	
	90	23	41,0	0,63	6308		130	31	87,1	1,90	6410	
	90	23	41,0	0,63	6308-Z		55	72	9	8,84	0,083	61811
	90	23	41,0	0,63	6308-2Z			72	9	8,84	0,083	61811-2RZ
	90	23	41,0	0,63	6308-RS1			72	9	8,84	0,083	61811-2RS1
90	23	41,0	0,63	6308-2RS1	80	13		15,9	0,19	61911		
90	33	41,0	0,89	62308-2RS1	90	11		19,5	0,26	16011		
	110	27	63,7	1,25	6408	90	18	28,1	0,39	6011		
45	58	7	6,05	0,040	61809	90	18	28,1	0,39	6011-Z		
	58	7	6,05	0,040	61809-2RS1	90	18	28,1	0,39	6011-2Z		
	68	12	14,0	0,14	61909	90	18	28,1	0,39	6011-RS1		
	68	12	14,0	0,14	61909-2RZ	90	18	28,1	0,39	6011-2RS1		
	68	12	14,0	0,14	61909-2RS1	100	21	43,6	0,61	6211		
	75	10	15,6	0,17	16009	100	21	43,6	0,61	6211-Z		
	75	16	20,8	0,25	6009	100	21	43,6	0,61	6211-2Z		
	75	16	20,8	0,25	6009-Z	100	21	43,6	0,61	6211-RS1		
	75	16	20,8	0,25	6009-2Z	100	21	43,6	0,61	6211-2RS1		
	75	16	20,8	0,25	6009-RS1	100	25	43,6	0,70	62211-2RS1		
	75	16	20,8	0,25	6009-2RS1	120	29	71,5	1,35	6311		
85	19	33,2	0,41	6209	120	29	71,5	1,35	6311-Z			
85	19	33,2	0,41	6209-Z	120	29	71,5	1,35	6311-2Z			
85	19	33,2	0,41	6209-2Z	120	29	71,5	1,35	6311-RS1			
85	19	33,2	0,41	6209-RS1	120	29	71,5	1,35	6311-2RS1			
85	19	33,2	0,41	6209-2RS1	60	140	33	99,5	2,30	6411		
85	23	33,2	0,48	62209-2RS1		78	10	8,71	0,11	61812		
100	25	52,7	0,83	6309		78	10	8,71	0,11	61812-2RS1		
100	25	52,7	0,83	6309-Z		85	13	16,5	0,20	61912		
100	25	52,7	0,83	6309-2Z		95	11	19,9	0,28	16012		
100	25	52,7	0,83	6309-RS1	95	18	29,6	0,42	6012			
100	25	52,7	0,83	6309-2RS1	95	18	29,6	0,42	6012-Z			
100	36	52,7	1,15	62309-2RS1	95	18	29,6	0,42	6012-2Z			
	120	29	76,1	1,55	6409	95	18	29,6	0,42	6012-RS1		
50	65	7	62,4	0,052	61810	95	18	29,6	0,42	6012-2RS1		
	65	7	62,4	0,052	61810-2RS1	110	22	52,7	0,78	6212		
	72	12	14,6	0,14	61910	110	22	52,7	0,78	6212-Z		
	72	12	14,6	0,14	61910-2RS1	110	22	52,7	0,78	6212-2Z		
	80	10	16,3	0,18	16010	110	22	52,7	0,78	6212-RS1		
	80	16	21,6	0,26	6010	110	22	52,7	0,78	6212-2RS1		
	80	16	21,6	0,26	6010-Z	110	28	52,7	0,97	62212-2RS1		
	80	16	21,6	0,26	6010-2Z	130	31	81,9	1,70	6312		
	80	16	21,6	0,26	6010-RS1	130	31	81,9	1,70	6312-Z		
	80	16	21,6	0,26	6010-2RS1	130	31	81,9	1,70	6312-2Z		
90	20	35,1	0,46	6210	130	31	81,9	1,70	6312-RS1			
90	20	35,1	0,46	6210-Z	130	31	81,9	1,70	6312-2RS1			
90	20	35,1	0,46	6210-2Z	65	150	35	108	2,75	6412		
90	20	35,1	0,46	6210-2ZNR		85	10	11,9	0,13	61813		
90	20	35,1	0,46	6210-RS1		85	10	11,9	0,13	61813-2RS1		
90	20	35,1	0,46	6210-2RS1		90	13	17,4	0,22	61913		
90	23	35,1	0,52	62210-2RS1								

Deep groove ball bearings
single row
d 95–220 mm

Dimensions					Basic load rating dynamic C	Mass	Designation	Dimensions						
d	D	B						d	D	B				
mm					kN	kg	–	mm						
95	145	16	42,3	0,89	16019	–	–	165	18	37,7	0,93	61826		
	145	24	60,5	1,20				6019	165	18	37,7		0,93	61826-2RS1
	145	24	60,5	1,20				6019-Z	200	22	79,3	2,35	16026	
	145	24	60,5	1,20				6019-2Z	200	33	106	3,15		6026
	145	24	60,5	1,20				6019-2RS1	230	40	156	5,80	6226	
	170	32	108	2,60	6219	280	58	229	18,0					
	170	32	108	2,60	6219-Z	140	175	18	39,0	0,99	61828			
	170	32	108	2,60	6219-2Z		175	18	39,0	0,99		61828-2RS1		
	200	45	153	5,65	6319	210	22	80,6	2,50	16028				
	100	125	13	19,9	0,31	61820	–	–	210		33	111	3,35	6028
125		13	19,9	0,31	61820-2RS1				250	42	165	7,45	6228	
150		16	44,2	0,91	16020	–	–	300	62	251	22,0	6328 M		
150		24	60,5	1,25				6020	150	190	20		48,8	1,40
150		24	60,5	1,25				6020-Z	225	24	92,2	3,15	16030	
150		24	60,5	1,25				6020-2Z	225	35	125	4,80		6030
150		24	60,5	1,25				6020-2RS1	270	45	174	9,40	6230	
180		34	124	3,15	6220	320	65	276	26,0	6330 M				
180		34	124	3,15	6220-Z	160	200	20	49,4		1,45	61832 MA		
180		34	124	3,15	6220-2Z		240	25	99,5	3,70	16032			
180	34	124	3,15	6220-2RS1	240	38	143	5,90	6032 M					
215	47	174	7,00	6320	290	48	186	14,5		6232 M				
105	130	13	20,8	0,32	61821	–	–	215	22		61,8	1,90	61834	
	130	13	20,8	0,32				61821-2RS1	260	28	119	5,00		16034
	160	18	52,0	1,20	16021	–	–	260	42	168	7,90	6034 M		
	160	26	72,8	1,60				6021	310	52	212		17,5	6234 M
	160	26	72,8	1,60				6021-2Z	180	225	22	62,4	2,00	
	160	26	72,8	1,60				6021-2RS1		280	31	138	6,60	16036
	190	36	133	3,70				6221	280	46	190	10,5	6036 M	
	190	36	133	3,70	6221-2Z	320	52	229	18,5	6236 M				
	225	49	182	8,25	6321	190	240	24	76,1		2,60	61838 MA		
	110	140	16	28,1	0,60		61822	–	–	290	31		148	7,90
140		16	28,1	0,60	61822-2RS1	290				46	195	11,0	6038 M	
170		19	57,2	1,45	16022	–	–	340	55	255	23,0	6238 M		
170		28	81,9	1,95				6022	200	250	24		76,1	2,70
170		28	81,9	1,95				6022-Z	310	34	168	8,85	16040	
170		28	81,9	1,95				6022-2Z	310	51	216	14,0		6040 M
170		28	81,9	1,95				6022-2RS1	360	58	270	28,0	6240 M	
200		38	143	4,35	6222	220	270	24	78	3,00	61844 MA			
200		38	143	4,35	6222-2Z		340	37	174	11,5		16044		
240		50	203	9,55	6322	340	56	247	18,5	6044 M				
120	150	16	29,1	0,65	61824	–	–	200	250		24	76,1	2,70	
	150	16	29,1	0,65						61824-2RS1				
	180	19	60,5	1,60	16024	–	–							
	180	28	85,2	2,05						6024				
	180	28	85,2	2,05						6024-Z				
	180	28	85,2	2,05						6024-2Z				
	180	28	85,2	2,05						6024-2RS1				
	215	40	146	5,15	6224									
	260	55	208	14,5	6324									

**Deep groove ball bearings
single row**
d 240–380 mm

Dimensions			Basic load rating dynamic C	Mass	Designation
d	D	B			
mm			kN	kg	–
240	300	28	108	4,50	61848 MA
	360	37	178	14,5	16048 MA
	360	56	255	19,5	6048 M
260	320	28	111	4,80	61852 MA
280	350	33	138	7,40	61856 MA
300	380	38	172	10,5	61860 MA
320	400	38	172	11,0	61864 MA
340	420	38	178	11,5	61868 MA
360	440	38	182	12,0	61872 MA
380	480	46	242	20,0	61876 MA

**Deep groove ball bearings
double row**
d 10–80 mm

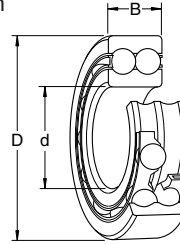

Dimensions			Basic load rating dynamic C	Mass	Designation
d	D	B			
mm			kN	kg	–
10	30	14	9,23	0,049	4200 ATN9
12	32	14	10,6	0,053	4201 ATN9
	42	17	14,8	0,12	4202 ATN9 4302 ATN9
17	40	16	14,8	0,09	4203 ATN9
	47	19	19,5	0,16	4303 ATN9
20	47	18	17,8	0,14	4204 ATN9
	52	21	23,4	0,21	4304 ATN9
25	52	18	19,0	0,16	4205 ATN9
	62	24	31,9	0,34	4305 ATN9
30	62	20	26,0	0,26	4206 ATN9
	72	27	41,0	0,50	4306 ATN9
35	72	23	35,1	0,40	4207 ATN9
	80	31	50,7	0,69	4307 ATN9
40	80	23	37,1	0,50	4208 ATN9
	90	33	55,9	0,95	4308 ATN9
45	85	23	39,0	0,54	4209 ATN9
	100	36	68,9	1,25	4309 ATN9
50	90	23	41,0	0,58	4210 ATN9
	110	40	81,9	1,70	4310 ATN9
55	100	25	44,9	0,80	4211 ATN9
	120	43	97,5	2,15	4311 ATN9
60	110	28	57,2	1,10	4212 ATN9
	130	46	112	2,65	4312 ATN9
65	120	31	67,6	1,45	4213 ATN9
70	125	31	70,2	1,50	4214 ATN9
75	130	31	72,8	1,60	4215 ATN9
80	140	33	80,6	2,00	4216 ATN9



Self-aligning ball bearings

Self-aligning ball bearings can accommodate angular misalignments of the shaft with respect to the housing and can withstand shaft bending in operation.

SKF self-aligning ball bearings have an optimised internal design and extremely low friction as well as

- enhanced load carrying capacity, and
- extended life, or
- enhanced reliability.

The excellent price/performance ratio of the SKF bearings as well as the comprehensive range are further advantages.

Range

SKF self-aligning ball bearings are available in open (no seals) and sealed designs as well as with an extended inner ring. They are produced with cylindrical as well as tapered bore (taper 1:12).

The bearings with seals at both sides are filled with a lithium base grease. This has good rust inhibiting properties and can be used at temperatures between -30 and

$+110$ °C. The sealed bearings are lubricated for life and maintenance-free.

Adapter sleeves, see page 158, can be supplied for use with bearings having a tapered bore. The sleeves enable quick and easy location of the bearings on smooth or stepped shafts. Bearings of the -2RS1KTN9 design require C-design adapter sleeves. Suitable mounting tools are also available from SKF, see page 25.

Dimensions

The boundary dimensions of the bearings listed in the tables are in accordance with ISO 15-1981; those of the bearings with extended inner ring are in accordance with DIN 630 Part 2, 1960.

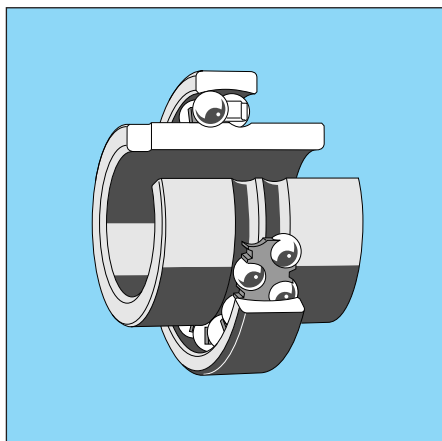
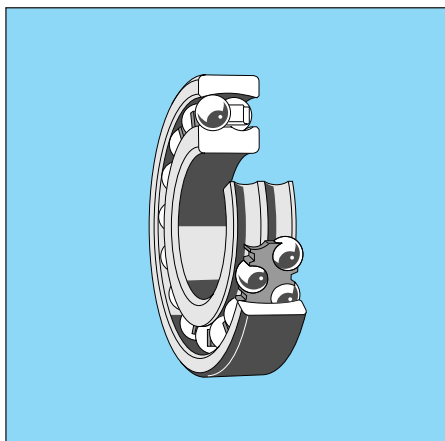

Tolerances

SKF self-aligning ball bearings are produced to Normal tolerances to ISO 492:1994 as standard. To make mounting easy, the bore of bearings with extended inner ring is, however, to tolerance J7.

Internal clearance

SKF self-aligning ball bearings with cylindrical bore are produced with Normal radial internal clearance and those with tapered bore with C3 radial internal clearance as standard. The clearance limits are as specified in ISO 5753:1991. The bearings of series 112 have a radial internal clearance of 10 to 30 µm.

Cages

Depending on series and size, SKF self-aligning ball bearings incorporate

- a polyamide 6,6 cage,
- a glass fibre reinforced polyamide 6,6 cage,
- a pressed steel cage, or
- a machined brass cage.

Some bearings which normally have a polyamide 6,6 cage or a pressed steel cage can also be supplied with a machined brass cage instead. Bearings with polyamide cages can normally be used at temperatures up to +120 °C. For further information see page 30.

Supplementary designations

The suffixes which are frequently used for SKF self-aligning ball bearings are explained in the following.

C3	Radial internal clearance greater than Normal
E	Optimised internal design
EKTN9	E + K + TN9
EM	E + M
ETN9	E + TN9
K	Tapered bore, taper 1:12
KM	K + M
KTN9	K + TN9
M	Machined brass cage
-2RS1	Synthetic rubber seal (rubbing seal) with sheet steel reinforcement at both sides of bearing
-2RS1KTN9	2RS1 + K + TN9
-2RS1TN9	2RS1 + TN9
TN	Injection moulded polyamide 6,6 cage
TN9	Injection moulded glass fibre reinforced polyamide 6,6 cage

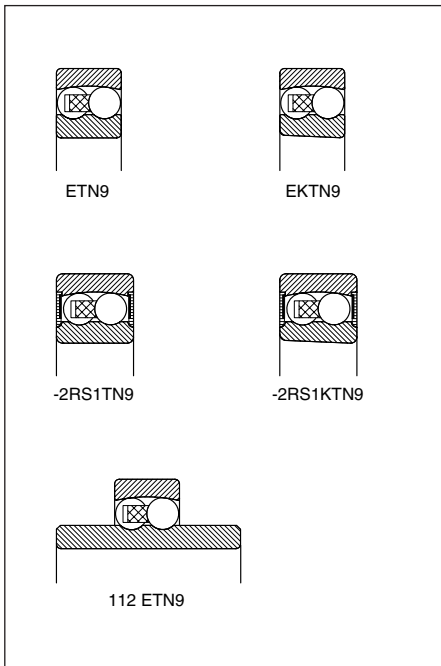

Self-aligning ball bearings

d 5–25 mm

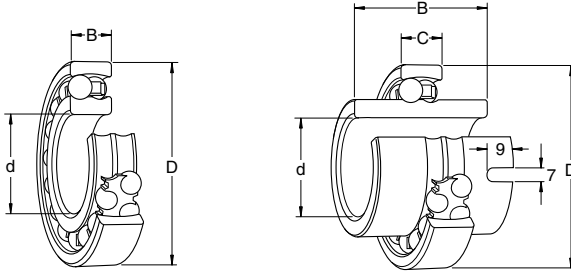

Dimensions			Basic load rating dynamic C	Mass	Designations	
d	D	B/C			Bearing with cylindrical bore	tapered bore
mm			kN	kg	–	
5	19	6	2,51	0,009	135 TN	–
6	19	6	2,51	0,009	126 TN	–
7	22	7	2,65	0,014	127 TN	–
8	22	7	2,65	0,014	108 TN	–
9	26	8	3,90	0,022	129 TN	–
10	30	9	5,53	0,034	1200 ETN9	–
	30	14	8,06	0,047	2200 ETN9	–
	30	14	5,53	0,048	2200 E-2RS1TN9	–
12	32	10	6,24	0,040	1201 ETN9	–
	32	14	8,52	0,053	2201 ETN9	–
	32	14	6,24	0,053	2201 E-2RS1TN9	–
	37	12	9,36	0,067	1301 ETN9	–
	37	17	11,7	0,095	2301	–
15	35	11	7,41	0,049	1202 ETN9	–
	35	14	8,71	0,060	2202 ETN9	–
	35	14	7,41	0,058	2202 E-2RS1TN9	–
	42	13	10,8	0,094	1302 ETN9	–
	42	17	11,9	0,110	2302	–
	42	17	10,8	0,110	2302 E-2RS1TN9	–
17	40	12	8,84	0,073	1203 ETN9	–
	40	16	10,6	0,088	2203 ETN9	–
	40	16	8,84	0,089	2203 E-2RS1TN9	–
	47	14	12,7	0,13	1303 ETN9	–
	47	19	14,6	0,16	2303	–
	47	19	12,7	0,16	2303 E-2RS1TN9	–
20	47	14	12,7	0,12	1204 ETN9	–
	47	40/14	12,7	0,18	11204 ETN9	–
	47	18	16,8	0,14	2204 ETN9	–
	47	18	12,7	0,14	2204 E-2RS1TN9	–
	52	15	14,3	0,16	1304 ETN9	–
	52	21	18,2	0,22	2304 TN	–
	52	21	14,3	0,21	2304 E-2RS1TN9	–
25	52	15	14,3	0,14	1205 ETN9	1205 EKTN9/C3
	52	44/15	14,3	0,22	11205 ETN9	–
	52	18	16,8	0,16	2205 ETN9	2205 EKTN9/C3
	52	18	14,3	0,16	2205 E-2RS1TN9	2205 E-2RS1KTN9/C3
	62	17	19	0,26	1305 ETN9	1305 EKTN9
	62	24	24,2	0,34	2305 ETN9	–
	62	24	24,2	0,34	2305 M	–
	62	24	19	0,34	2305 E-2RS1TN9	–

Self-aligning ball bearings

d 30–65 mm

Dimensions			Basic load rating dynamic C	Mass	Designations Bearing with cylindrical bore	tapered bore	
d	D	B/C					
mm			kN	kg	–		
30	62	16	15,6	0,22	1206 ETN9	1206 EKTN9/C3	
	62	48/16	15,6	0,35	11206 ETN9	–	
	62	20	23,8	0,26	2206 ETN9	2206 EKTN9/C3	
	62	20	15,6	0,26	2206 E-2RS1TN9	2206 E-2RS1KTN9/C3	
	72	19	22,5	0,39	1306 ETN9	1306 EKTN9/C3	
	72	27	31,2	0,50	2306	2306 K/C3	
	72	27	31,2	0,50	2306 M	–	
	72	27	22,5	0,51	2306 E-2RS1TN9	–	
	35	72	17	19	0,32	1207 ETN9	1207 EKTN9/C3
		72	52/17	19	0,54	11207 ETN9	–
72		23	30,7	0,40	2207 ETN9	2207 EKTN9/C3	
72		23	19	0,41	2207 E-2RS1TN9	2207 E-2RS1KTN9/C3	
80		21	26,5	0,51	1307 ETN9	1307 EKTN9/C3	
80		31	39,7	0,68	2307 ETN9	2307 EKTN9/C3	
80		31	39,7	0,70	2307 EM	–	
80		31	26,5	0,70	2307 E-2RS1TN9	–	
40	80	18	19,9	0,42	1208 ETN9	1208 EKTN9/C3	
	80	56/18	19,9	0,72	11208 ETN9	–	
	80	23	31,9	0,51	2208 ETN9	2208 EKTN9/C3	
	80	23	19,9	0,50	2208 E-2RS1TN9	2208 E-2RS1KTN9/C3	
	90	23	33,8	0,72	1308 ETN9	1308 EKTN9/C3	
	90	33	54	0,93	2308 ETN9	2308 EKTN9/C3	
	90	33	54	0,93	2308 EM	–	
	90	33	33,8	0,96	2308 E-2RS1TN9	–	
	45	85	19	22,9	0,47	1209 ETN9	1209 EKTN9/C3
		85	58/19	22,9	0,77	11209 ETN9	–
85		23	32,5	0,55	2209 ETN9	2209 EKTN9/C3	
85		23	22,9	0,53	2209 E-2RS1TN9	2209 E-2RS1KTN9/C3	
100		25	39	0,96	1309 ETN9	1309 EKTN9/C3	
100		36	63,7	1,25	2309 ETN9	2309 EKTN9/C3	
100		36	63,7	1,30	2309 EM	–	
100		36	39	1,30	2309 E-2RS1TN9	–	
50	90	20	26,5	0,53	1210 ETN9	1210 EKTN9/C3	
	90	58/20	26,5	0,85	11210 ETN9	–	
	90	23	33,8	0,60	2210 ETN9	2210 EKTN9/C3	
	90	23	26,5	0,57	2210 E-2RS1TN9	2210 E-2RS1KTN9/C3	
	110	27	43,6	1,20	1310 ETN9	1310 EKTN9/C3	
	110	50	63,7	1,65	2310	2310 K/C3	
	110	40	63,7	1,70	2310 M	–	
	110	40	43,6	1,65	2310 E-2RS1TN9	–	
55	100	21	27,6	0,71	1211 ETN9	1211 EKTN9/C3	
	100	25	39	0,81	2211 ETN9	2211 EKTN9/C3	
	100	25	27,6	0,79	2211 E-2RS1TN9	2211 E-2RS1KTN9/C3	
	120	29	50,7	1,60	1311 ETN9	1311 EKTN9/C3	
	120	43	76,1	2,10	2311	2311 EKTN9/C3	
	60	110	22	31,2	0,90	1212 ETN9	1212 EKTN9/C3
110		28	48,8	1,10	2212 ETN9	2212 EKTN9/C3	
110		28	31,2	1,05	2212 E-2RS1TN9	–	
130		31	58,5	1,95	1312 ETN9	1312 EKTN9/C3	
130		46	87,1	2,60	2312	2312 K/C3	
65	120	23	35,1	1,15	1213 ETN9	1213 EKTN9/C3	
	120	31	57,2	1,45	2213 ETN9	2213 EKTN9/C3	
	120	31	35,1	1,40	2213 E-2RS1TN9	2213 E-2RS1KTN9/C3	



Self-aligning ball bearings

d 65–110 mm

Dimensions			Basic load rating dynamic C	Mass	Designations Bearing with cylindrical bore	tapered bore																																																																																																																																																																																																											
d	D	B ¹⁾																																																																																																																																																																																																															
mm			kN	kg	–																																																																																																																																																																																																												
65 (cont.)	140	33	65	2,45	1313 ETN9 2313	1313 EKTN9/C3 2313 EKTN9/C3																																																																																																																																																																																																											
	140	48	95,6	3,25			70	125	24	34,5	1,25	1214	1214 K/C3	125	31	44,2	1,50	2214	–	125	31	34,5	1,50	2214-2RS1	–	150	35	74,1	3,00	1314	–	150	51	111	3,90	2314	–	150	51	111	4,00	2314 M	–	75	130	25	39	1,35	1215	1215 K/C3	130	31	44,2	1,60	2215 ETN9	2215 EKTN9/C3	160	37	79,3	3,55	1315	1315 K/C3	160	55	124	4,70	2315	2315 K/C3	160	55	124	4,70	2315 M	–	80	140	26	39,7	1,65	1216	1216 K/C3	140	33	65	2,00	2216 ETN9	2216 EKTN9/C3	170	39	88,4	4,20	1316	1316 K/C3	170	58	135	6,10	2316	2316 K/C3	170	58	135	6,30	2316 M	–	85	150	28	48,8	2,05	1217	1217 K/C3	150	36	58,5	2,50	2217	2217 K/C3	180	41	97,5	5,00	1317	1317 K/C3	180	60	140	7,05	2317 M	2317 KM/C3	90	160	30	57,2	2,50	1218	1218 K/C3	160	40	70,2	3,40	2218	2218 K/C3	190	43	117	5,80	1318	1318 K/C3	190	64	153	8,45	2318 M	2318 KM/C3	95	170	32	63,7	3,10	1219	1219 K/C3	170	43	83,2	4,10	2219 M	–	200	45	133	6,70	1319	–	100	180	34	68,9	3,70	1220	1220 K/C3	180	46	97,5	5,00	2220 M	2220 KM/C3	215	47	143	8,30	1320	1320 K/C3	110	200	38	88,4	5,15	1222	1222 K/C3	200	53	124	7,10	2222 M	2222 KM/C3	240	50	163
70	125	24	34,5	1,25	1214	1214 K/C3																																																																																																																																																																																																											
	125	31	44,2	1,50	2214	–																																																																																																																																																																																																											
	125	31	34,5	1,50	2214-2RS1	–																																																																																																																																																																																																											
	150	35	74,1	3,00	1314	–																																																																																																																																																																																																											
	150	51	111	3,90	2314	–																																																																																																																																																																																																											
	150	51	111	4,00	2314 M	–																																																																																																																																																																																																											
75	130	25	39	1,35	1215	1215 K/C3																																																																																																																																																																																																											
	130	31	44,2	1,60	2215 ETN9	2215 EKTN9/C3																																																																																																																																																																																																											
	160	37	79,3	3,55	1315	1315 K/C3																																																																																																																																																																																																											
	160	55	124	4,70	2315	2315 K/C3																																																																																																																																																																																																											
	160	55	124	4,70	2315 M	–																																																																																																																																																																																																											
	80	140	26	39,7	1,65	1216	1216 K/C3																																																																																																																																																																																																										
140		33	65	2,00	2216 ETN9	2216 EKTN9/C3																																																																																																																																																																																																											
170		39	88,4	4,20	1316	1316 K/C3																																																																																																																																																																																																											
170		58	135	6,10	2316	2316 K/C3																																																																																																																																																																																																											
170		58	135	6,30	2316 M	–																																																																																																																																																																																																											
85		150	28	48,8	2,05	1217	1217 K/C3																																																																																																																																																																																																										
	150	36	58,5	2,50	2217	2217 K/C3																																																																																																																																																																																																											
	180	41	97,5	5,00	1317	1317 K/C3																																																																																																																																																																																																											
	180	60	140	7,05	2317 M	2317 KM/C3																																																																																																																																																																																																											
	90	160	30	57,2	2,50	1218	1218 K/C3																																																																																																																																																																																																										
		160	40	70,2	3,40	2218	2218 K/C3																																																																																																																																																																																																										
190		43	117	5,80	1318	1318 K/C3																																																																																																																																																																																																											
190		64	153	8,45	2318 M	2318 KM/C3																																																																																																																																																																																																											
95	170	32	63,7	3,10	1219	1219 K/C3																																																																																																																																																																																																											
	170	43	83,2	4,10	2219 M	–																																																																																																																																																																																																											
	200	45	133	6,70	1319	–																																																																																																																																																																																																											
	100	180	34	68,9	3,70	1220	1220 K/C3																																																																																																																																																																																																										
180		46	97,5	5,00	2220 M	2220 KM/C3																																																																																																																																																																																																											
215		47	143	8,30	1320	1320 K/C3																																																																																																																																																																																																											
110	200	38	88,4	5,15	1222	1222 K/C3																																																																																																																																																																																																											
	200	53	124	7,10	2222 M	2222 KM/C3																																																																																																																																																																																																											
	240	50	163	12,0	1322 M	1322 KM/C3																																																																																																																																																																																																											

¹⁾ The balls of bearings 1318 (K) to 1322 (K) protrude 1 to 2,6 mm from the side faces

Angular contact ball bearings

Angular contact ball bearings have raceways in the inner and outer rings which are displaced with respect to each other in the direction of the bearing axis. This means that they are particularly suitable for the accommodation of combined loads, i.e. simultaneously acting radial and axial loads. The single row bearings can take up axial loads acting in one direction only, and are therefore usually adjusted against a second bearing.

The range and performance of SKF angular contact ball bearings are remarkable. There is a wide choice of single row bearings for mounting singly as well as “universal” bearings for mounting in paired arrangements, and the size range is large. This is also true of the double row bearings which are available in open and sealed versions. The performance and reliability of SKF angular contact ball bearings result from

- their optimised internal design,
- high running accuracy, and
- robust quality.

The benefits are high load carrying capacity

and speed capability, low operating temperatures, long relubrication intervals and quiet operation.

Range

The SKF popular range includes both single and double row angular contact ball bearings.

Single row bearings

The single row angular contact ball bearings shown in the tables have a contact angle of 40° , are non-separable and can be operated at relatively high speeds. Two executions are available which are intended for different types of arrangement. The “normal” execution is used where a single bearing is required at each bearing position. The “universal” execution is used where two or more bearings are to be mounted immediately adjacent to each other in random order.

Single row “universal” bearings are produced specially so that they can be mounted in pairs immediately adjacent to each other in any order and will then have a given posit-

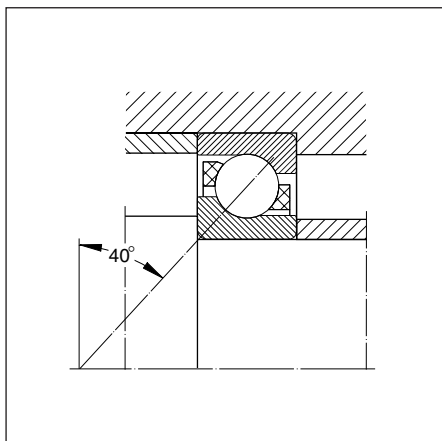
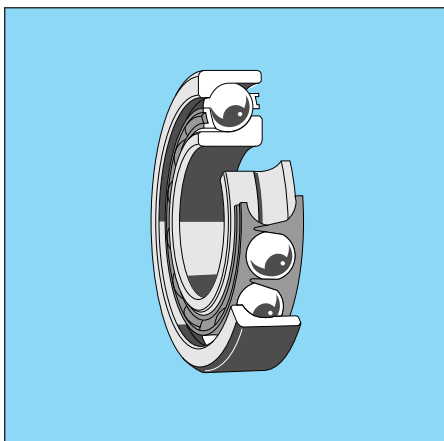

Angular contact ball bearings

ive or negative operational clearance and/or an even load distribution. Shims or other spacers are not required. Paired mounting is chosen when the load carrying capacity of a single bearing is insufficient or when the arrangement is subjected to axial loads acting in both directions.

Double row bearings

SKF double row angular contact ball bearings of the A design are the most recent. Their internal geometry has been optimised, they have a contact angle of 32° and are without filling slots. The other SKF double row bearings have filling slots at one side, but this design is being gradually replaced by the A design. Bearings with filling slots should be mounted so that the main axial load is taken by the raceways on the side without filling slots.

The sealed bearings are filled with a lithium base grease. This has good rust inhibiting properties and can be used at temperatures between -30 and $+110$ °C. The sealed bearings are lubricated for life and maintenance-free.

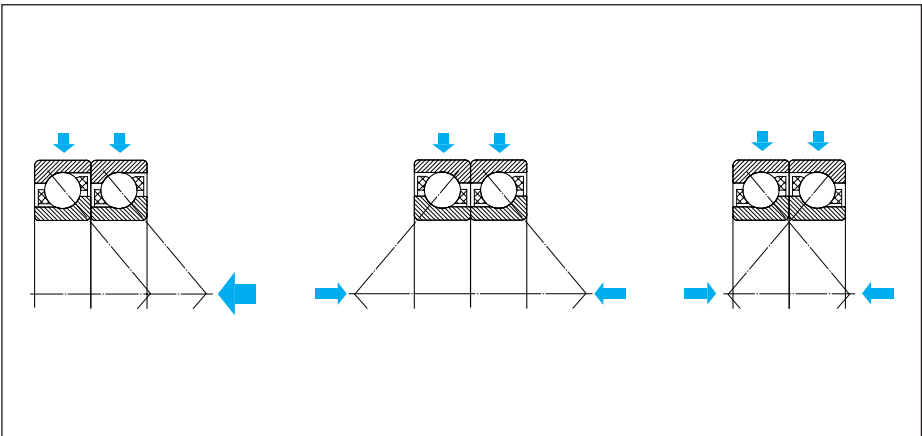
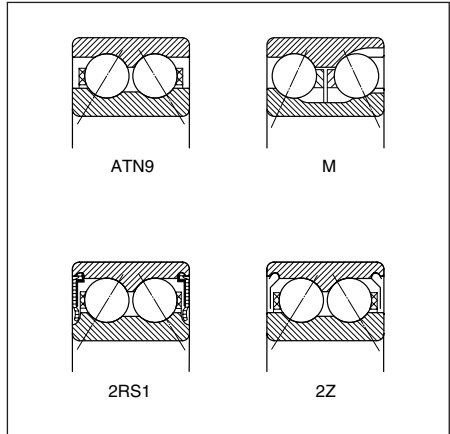
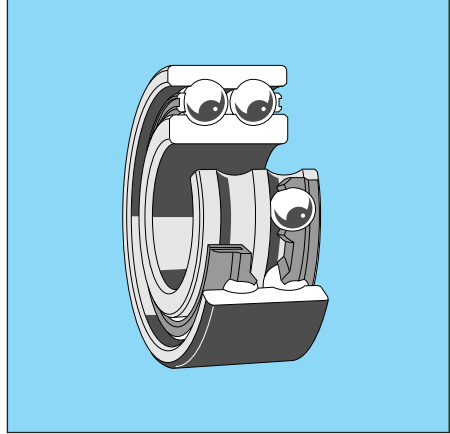

Dimensions

The boundary dimensions of the single and double row angular contact ball bearings listed in the tables are in accordance with ISO 15-1981, except for the width of bearing 3200 A.

Tolerances

SKF angular contact ball bearings are produced to Normal tolerances as standard. The single row “universal” bearings, however, have higher accuracy to class P6 as standard. The tolerances conform to ISO 492:1994.

Internal clearance

Single row bearings

The “universal” bearings of the CB type are the SKF standard bearings for paired mounting. After they are mounted in back-to-back or face-to-face arrangements they will have a small axial clearance.

Double row bearings

SKF double row angular contact ball bearings have Normal axial internal clearance as standard, which, depending on bearing size is from 5 to 53 μm . Some bearings are available with larger or smaller axial internal clearance. Availability should be checked before ordering.

Cages

Depending on bearing series and size, SKF angular contact ball bearings incorporate a

- a glass fibre reinforced polyamide 6,6 cage,
- a pressed steel cage (standard for double row bearings, therefore no suffix), or
- a machined brass cage.

Some single row bearings with polyamide 6,6 cages can also be supplied with a machined brass cage instead. Bearings with polyamide cages can normally be used at temperatures up to +120 °C. For further information, see page 30.

Angular contact ball bearings

Supplementary designations

The suffixes which are frequently used for SKF row angular contact ball bearings are explained in the following.

A	Optimised internal design, without filling slots	P	Injection moulded glass fibre reinforced polyamide 6,6 cage
ATN9	A + TN9	P6	Increased dimensional and running accuracy (better than Normal) to ISO tolerance class 6
B	40° contact angle	-2RS1	Synthetic rubber seal (rubbing seal) with sheet metal reinforcement at both sides of bearing
BCBM	B + CB + M	-2RS1TN9	2RS1 + TN9
BECBM	B + E + CB + M	TN9	Injection moulded glass fibre reinforced polyamide 6,6 cage
BECBP	B + E + CB + P	-2Z	Pressed steel shield (non-rubbing seal) at both sides of bearing
BEM	B + E + M	-2ZTN9	2Z + TN9
BEP	B + E + P		
BGM	B + G + M		
BM	B + M		
C2	Radial internal clearance smaller than Normal		
C3	Radial internal clearance greater than Normal		
CA	Bearings for universal pairing with a smaller than normal axial clearance after mounting back-to-back or face-to-face		
CB	Bearings for universal pairing with a normal axial clearance after mounting back-to-back or face-to-face		
CC	Bearings for universal pairing with a greater than normal axial clearance after mounting back-to-back or face-to-face		
E	Optimised internal design		
F	Machined steel cage		
G	Larger bearings for universal pairing with a normal axial clearance after mounting back-to-back or face-to-face		
GA	Bearings for universal pairing with a light preload after mounting back-to-back or face-to-face		
GB	Bearings for universal pairing with a moderate preload after mounting back-to-back or face-to-face		
GC	Bearings for universal pairing with a heavy preload after mounting back-to-back or face-to-face		
M	Machined brass cage, ball centred		

Angular contact ball bearings

single row

d 10–70 mm

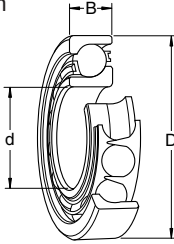

Dimensions			Basic load rating dynamic C	Mass kg	Designation
d	D	B			
mm			kN	kg	–
10	30	9	7,02	0,030	7200 BEP
12	32	10	7,61	0,036	7201 BEP
	32	10	7,61	0,036	7201 BECBP
15	35	11	8,84	0,045	7202 BEP
	35	11	8,84	0,045	7202 BECBP
42	13	13	0,080		7302 BEP
	42	13	0,080		7302 BECBP
17	40	12	11,1	0,065	7203 BEP
	40	12	11,1	0,065	7203 BECBP
20	47	14	15,9	0,11	7303 BEP
	47	14	14	0,11	7204 BEP
	47	14	14	0,11	7204 BECBP
52	15	19	0,14		7304 BEP
	52	15	19	0,14	7304 BECBP
	52	15	17,4	0,14	7304 BECBM
25	52	15	15,6	0,13	7205 BEP
	52	15	15,6	0,13	7205 BECBP
	52	15	14,8	0,13	7205 BECBM
62	17	26	0,23		7305 BEP
	62	17	26	0,23	7305 BECBP
	62	17	24,2	0,23	7305 BECBM
30	62	16	23,8	0,20	7206 BEP
	62	16	23,8	0,20	7206 BECBP
	62	16	22,5	0,20	7206 BECBM
72	19	34,5	0,34		7306 BEP
	72	19	34,5	0,34	7306 BECBP
	72	19	32,5	0,34	7306 BECBM
35	72	17	30,7	0,28	7207 BEP
	72	17	30,7	0,28	7207 BECBP
	72	17	29,1	0,28	7207 BECBM
80	21	39	0,45		7307 BEP
	80	21	39	0,45	7307 BECBP
	80	21	39	0,45	7307 BECBM
40	80	18	36,4	0,37	7208 BEP
	80	18	36,4	0,37	7208 BECBP
	80	18	34,5	0,37	7208 BECBM
90	23	49,4	0,63		7308 BEP
	90	23	49,4	0,63	7308 BECBP
	90	23	46,2	0,63	7308 BECBM

Dimensions			Basic load rating dynamic C	Mass kg	Designation
d	D	B			
mm			kN	kg	–
40	110	27	70,2	1,40	7408 BM
	(cont.) 110	27	70,2	1,40	7408 BGM
45	85	19	37,7	0,42	7209 BEP
	85	19	37,7	0,42	7209 BECBP
	85	19	35,8	0,42	7209 BECBM
100	25	60,5	0,85		7309 BEP
	100	25	60,5	0,85	7309 BECBP
	100	25	55,9	0,83	7309 BECBM
50	90	20	39	0,47	7210 BEP
	90	20	39	0,47	7210 BECBP
	90	20	37,7	0,47	7210 BECBM
110	27	74,1	1,10		7310 BEP
	110	27	74,1	1,10	7310 BECBP
	110	27	68,9	1,10	7310 BECBM
130	31	95,6	2,25	7410 BGM	
55	100	21	48,8	0,62	7211 BEP
	100	21	48,8	0,62	7211 BECBP
	100	21	46,2	0,62	7211 BECBM
120	29	85,2	1,40		7311 BEP
	120	29	85,2	1,40	7311 BECBP
	120	29	79,3	1,40	7311 BECBM
140	33	111	2,75	7411 BGM	
60	110	22	57,2	0,80	7212 BEP
	110	22	57,2	0,80	7212 BECBP
	110	22	57,2	0,80	7212 BECBM
130	31	95,6	1,75		7312 BEP
	130	31	95,6	1,75	7312 BECBP
	130	31	95,6	1,75	7312 BECBM
65	120	23	66,3	1,00	7213 BEP
	120	23	66,3	1,00	7213 BECBP
	120	23	66,3	1,00	7213 BECBM
140	33	108	2,15		7313 BEP
	140	33	108	2,15	7313 BECBP
	140	33	108	2,15	7313 BECBM
70	125	24	71,5	1,10	7214 BEP
	125	24	71,5	1,10	7214 BECBP
	125	24	67,6	1,10	7214 BECBM
150	35	119	2,65		7314 BEP
	150	35	119	2,65	7314 BECBP
	150	35	119	2,65	7314 BECBM



Angular contact ball bearings
single row
d 75–280 mm

Dimensions			Basic load rating dynamic C	Mass	Designation
d	D	B			
mm			kN	kg	–
75	130	25	72,8	1,20	7215 BEP
	130	25	72,8	1,20	7215 BECBP
	130	25	70,2	1,20	7215 BECBM
	160	37	133	3,20	7315 BEP
	160	37	133	3,20	7315 BECBP
	160	37	125	3,20	7315 BECBM
80	140	26	83,2	1,45	7216 BEP
	140	26	83,2	1,45	7216 BECBP
	140	26	80,6	1,45	7216 BECBM
	170	39	143	3,80	7316 BEP
	170	39	143	3,80	7316 BECBP
	170	39	135	3,80	7316 BEM
	170	39	135	3,80	7316 BECBM
85	150	28	95,6	1,85	7217 BEP
	150	28	95,6	1,85	7217 BECBP
	150	28	95,6	1,85	7217 BECBM
	180	41	153	4,45	7317 BEP
	180	41	153	4,45	7317 BECBP
	180	41	146	4,45	7317 BEM
	180	41	146	4,45	7317 BECBM
90	160	30	108	2,30	7218 BEP
	160	30	108	2,30	7218 BECBP
	160	30	108	2,30	7218 BECBM
	190	43	165	5,20	7318 BEP
	190	43	165	5,20	7318 BECBP
	190	43	156	5,20	7318 BEM
	190	43	156	5,20	7318 BECBM
95	170	32	124	2,70	7219 BEP
	170	32	124	2,70	7219 BECBP
	170	32	124	2,70	7219 BEM
	170	32	124	2,70	7219 BECBM
	200	45	178	6,05	7319 BEP
200	45	178	6,05	7319 BECBP	
200	45	168	6,05	7319 BEM	
200	45	168	6,05	7319 BECBM	
100	180	34	135	3,30	7220 BEP
	180	34	135	3,30	7220 BECBP
	180	34	135	3,25	7220 BECBM
	215	47	203	7,50	7320 BEP
	215	47	203	7,50	7320 BECBP
	215	47	203	7,50	7320 BEM
	215	47	203	7,50	7320 BECBM
105	190	36	148	3,95	7221 BEP
	190	36	148	3,95	7221 BECBP
	190	36	148	3,85	7221 BECBM
	225	49	212	8,55	7321 BEP
	225	49	212	8,55	7321 BECBP
	225	49	203	8,45	7321 BECBM
110	200	38	163	4,60	7222 BEP
	200	38	163	4,60	7222 BECBP
	200	38	153	4,60	7222 BEM
	200	38	153	4,60	7222 BECBM

Dimensions			Basic load rating dynamic C	Mass	Designation
d	D	B			
mm			kN	kg	–
110 (cont.)	240	50	225	10,0	7322 BEP
	240	50	225	10,0	7322 BECBP
	240	50	225	10,0	7322 BEM
	240	50	225	10,0	7322 BECBM
120	180	28	87,1	2,40	7024 BGM
	215	40	165	6,10	7224 BM
	260	55	238	14,5	7324 BCBM
130	230	40	186	6,95	7226 BM
	280	58	251	17,5	7326 BM
	280	58	251	17,5	7326 BCBM
140	210	33	111	3,85	7028 BGM
	250	42	182	8,85	7228 BM
	250	42	182	8,85	7228 BCBM
	300	62	276	21,5	7328 BCBM
150	270	45	195	11,5	7230 BCBM
	320	65	302	26,0	7330 BCBM
160	290	48	199	14,0	7232 BCBM
	310	52	221	17,5	7234 BCBM
170	360	72	358	36,0	7334 BCBM
	320	52	251	18,0	7236 BCBM
240	360	56	260	19,0	7048 BGM
280	420	65	319	30,0	7056 BGM

Angular contact ball bearings

double row

d 10–110 mm

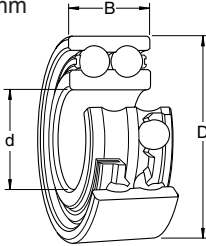

Dimensions			Basic load rating dynamic C	Mass	Designation
d	D	B			
mm	mm	mm	kN	kg	–
10	30	14	7,41	0,051	3200 ATN9
	30	14	7,41	0,051	3200 A-2RS1TN9
	30	14	7,41	0,051	3200 A-2ZTN9
12	32	15,9	10,1	0,058	3201 ATN9
	32	15,9	10,1	0,058	3201 A-2RS1TN9
	32	15,9	10,1	0,058	3201 A-2ZTN9
15	35	15,9	11,2	0,066	3202 ATN9
	35	15,9	11,2	0,066	3202 A-2RS1TN9
	35	15,9	11,2	0,066	3202 A-2ZTN9
17	42	19	15,1	0,13	3302 ATN9
	42	19	15,1	0,13	3302 A-2RS1TN9
	42	19	15,1	0,13	3302 A-2ZTN9
	47	22,2	21,2	0,18	3303 ATN9
17	40	17,5	14	0,096	3203 ATN9
	40	17,5	14	0,096	3203 A-2RS1TN9
	40	17,5	14	0,096	3203 A-2ZTN9
20	47	22,2	21,2	0,18	3303 ATN9
	47	22,2	21,2	0,18	3303 A-2RS1TN9
	47	22,2	21,2	0,18	3303 A-2ZTN9
20	47	20,6	18,6	0,16	3204 ATN9
	47	20,6	18,6	0,16	3204 A-2RS1TN9
	47	20,6	18,6	0,16	3204 A-2ZTN9
25	52	22,2	22,1	0,22	3304 ATN9
	52	22,2	22,1	0,22	3304 A-2RS1TN9
	52	22,2	22,1	0,22	3304 A-2ZTN9
	52	20,6	20,3	0,18	3205 ATN9
25	52	20,6	20,3	0,18	3205 A-2RS1TN9
	52	20,6	20,3	0,18	3205 A-2ZTN9
	62	25,4	31,2	0,35	3305 ATN9
30	62	25,4	31,2	0,35	3305 A-2RS1TN9
	62	25,4	31,2	0,35	3305 A-2ZTN9
	62	23,8	28,1	0,29	3206 ATN9
30	62	23,8	28,1	0,29	3206 A-2RS1TN9
	62	23,8	28,1	0,29	3206 A-2ZTN9
	72	30,2	41	0,53	3306 ATN9
30	72	30,2	41	0,53	3306 A-2RS1TN9
	72	30,2	41	0,53	3306 A-2ZTN9
	72	27	37,1	0,44	3207 ATN9
35	72	27	37,1	0,44	3207 A-2RS1TN9
	72	27	37,1	0,44	3207 A-2ZTN9
	80	34,9	48,8	0,73	3307 ATN9
35	80	34,9	48,8	0,73	3307 A-2RS1TN9
	80	34,9	48,8	0,73	3307 A-2ZTN9

Dimensions			Basic load rating dynamic C	Mass	Designation
d	D	B			
mm	mm	mm	kN	kg	–
40	80	30,2	44,9	0,58	3208 ATN9
	80	30,2	44,9	0,58	3208 A-2RS1TN9
	80	30,2	44,9	0,58	3208 A-2ZTN9
45	90	36,5	59,2	0,95	3308 ATN9
	90	36,5	59,2	0,95	3308 A-2RS1TN9
	90	36,5	59,2	0,95	3308 A-2ZTN9
50	90	30,2	47,5	0,66	3210 ATN9
	90	30,2	47,5	0,66	3210 A-2RS1TN9
	90	30,2	47,5	0,66	3210 A-2ZTN9
55	110	44,4	88	1,95	3310
	120	49,2	95,2	2,55	3311
60	110	36,5	72,1	1,40	3212
	130	54	112	3,25	3312
65	120	38,1	78,1	1,75	3213
	140	58,7	128	4,10	3313
70	125	39,7	76,5	1,90	3214
	150	63,5	147	5,05	3314
75	130	41,3	84,2	2,10	3215
	160	68,3	157	6,15	3315
80	140	44,4	101	2,65	3216
	170	68,3	176	6,95	3316
85	150	49,2	110	3,40	3217
	180	73	194	8,30	3317
90	160	52,4	128	4,15	3218
	190	73	220	9,25	3318
95	170	55,6	147	5,00	3219
	200	77,8	238	11,0	3319 M
100	180	60,3	157	6,10	3220
	215	82,6	255	13,5	3320 M
110	200	69,8	190	8,80	3222
	240	92,1	292	19,0	3322 M



Four-point contact ball bearings

Four-point contact ball bearings are single row angular contact ball bearings which are designed to carry heavy axial loads in both directions. They are not suitable for loads which are predominantly radial.

SKF four-point contact ball bearings have a split inner ring, a contact angle of 35° and a large number of large balls. The benefits are

- high axial load carrying capacity,
- high speed capability, and
- simple mounting.

Range

SKF four-point contact ball bearings having an outside diameter of 160 mm and above have two locating slots in the outer ring. This enables a simple means of preventing rotation of the outer ring which is mounted with a loose fit in the housing. Depending on bearing size, the slot width is 6,5 to 10,5 mm and the height is 8 to 12,7 mm. The angle is 45° .

Dimensions

The boundary dimensions of the bearings listed in the table are in accordance with ISO 15-1981.

Tolerances

SKF four-point contact ball bearings are produced to Normal tolerances as standard. The tolerances conform to ISO 492:1994.

Internal clearance

SKF four-point contact ball bearings have Normal axial internal clearance as standard. Depending on bearing size, this lies between 55 and 200 μm . Some sizes are also available with larger or smaller clearance; availability should be checked before ordering.

Cages

The bearings are fitted with an outer ring centred window-type cage of brass.

Supplementary designations

The suffixes which are frequently used for SKF four-point contact ball bearings are explained in the following.

C2	Axial internal clearance smaller than Normal
C2L	Axial internal clearance in lower half of C2 range
C3	Axial internal clearance greater than Normal
MA	Brass window-type cage, outer ring centred
N2	Two locating slots at 180° to each other in outer ring
N2MA	N2 + MA

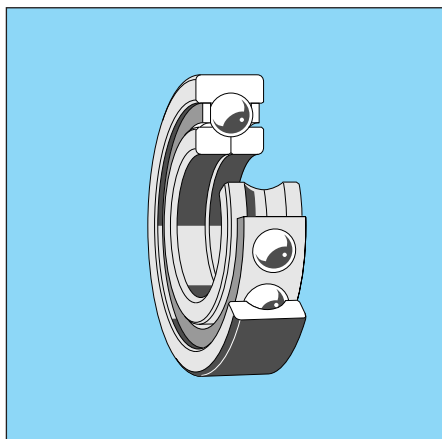

Four-point contact ball bearings d 20–170 mm

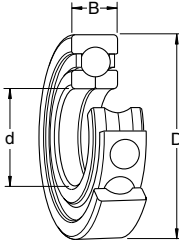

Dimensions			Basic load rating dynamic C	Mass kg	Designation
d	D	B			
mm			kN	kg	–
20	52	15	29,6	0,18	QJ 304 MA
30	62	16	35,1	0,24	QJ 206 MA
	72	19	49,4	0,42	QJ 306 MA
35	72	17	46,2	0,35	QJ 207 N2MA
	80	21	59,2	0,57	QJ 307 MA
40	80	18	52,7	0,45	QJ 208 MA
	90	23	71,5	0,78	QJ 308 MA
45	85	19	58,5	0,52	QJ 209 MA
	100	25	93,6	1,05	QJ 309 MA
50	90	20	61,8	0,59	QJ 210 MA
	110	27	111	1,35	QJ 310 MA
55	100	21	79,3	0,77	QJ 211 MA
	120	29	127	1,75	QJ 311 MA
60	110	22	92,3	0,99	QJ 212 MA
	130	31	146	2,15	QJ 312 MA
65	120	23	104	1,20	QJ 213 MA
	140	33	165	2,70	QJ 313 MA
70	125	24	114	1,30	QJ 214 MA
	150	35	186	3,15	QJ 314 MA
75	130	25	117	1,45	QJ 215 MA
	160	37	199	3,90	QJ 315 N2MA
80	140	26	138	1,85	QJ 216 MA
	170	39	216	4,60	QJ 316 N2MA
85	150	28	148	2,25	QJ 217 MA
	180	41	234	5,45	QJ 317 N2MA
90	160	30	174	2,75	QJ 218 N2MA
	190	43	265	6,45	QJ 318 N2MA
95	170	32	199	3,35	QJ 219 N2MA
	200	45	286	7,45	QJ 319 N2MA
100	180	34	225	4,05	QJ 220 N2MA
	215	47	307	9,30	QJ 320 N2MA
110	200	38	265	5,60	QJ 222 N2MA
	240	50	364	12,5	QJ 322 N2MA
120	215	40	286	6,95	QJ 224 N2MA
	260	55	390	16,0	QJ 324 N2MA
130	230	40	296	7,75	QJ 226 N2MA
	280	58	423	19,5	QJ 326 N2MA

Dimensions			Basic load rating dynamic C	Mass kg	Designation
d	D	B			
mm			kN	kg	–
140	250	42	325	9,85	QJ 228 N2MA
150	270	45	338	12,5	QJ 230 N2MA
	320	65	494	29,0	QJ 330 N2MA
160	290	48	390	15,5	QJ 232 N2MA
170	360	72	618	41,5	QJ 334 N2MA

Single row cylindrical roller bearings

Single row cylindrical roller bearings are produced in several different designs which differ in the arrangement and number of flanges. The cage and roller assembly is guided between integral flanges on one of the two bearing rings. The ring with these integral flanges and the cylindrical roller and cage assembly form a non-separable unit which can be mounted separately from the other bearing ring. This simplifies mounting, particularly in cases where both rings are to have an interference fit.

SKF cylindrical roller bearings represent the latest state of the art. The contact geometry between roller and raceway has been considerably improved by using the “log-arithmetic profile” and the optimised bearing surfaces promote lubricant film formation and the correct movement of the rollers. The favourable design of the roller end/flange contact increases the axial load carrying capacity and reduces running temperature. These features heighten the performance of SKF cylindrical roller bearings and the resulting benefits include even greater reliability and less sensitivity to misalignment.

Range

Cylindrical roller bearings of the NU, N, NJ and NUP designs are in continuous production at SKF and angle rings are produced for some of the NU and NJ bearings. The use of angle rings facilitates mounting and dismounting and enables the tight fit of the inner ring on its seating to be retained under heavy loads.

Dimensions

The boundary dimensions of the bearings listed in the tables are in accordance with ISO 15-1981 and the dimensions of the angle rings conform to ISO 246-1978.

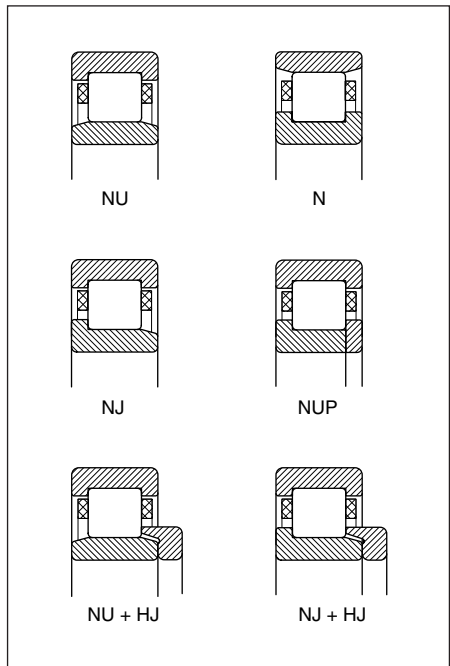
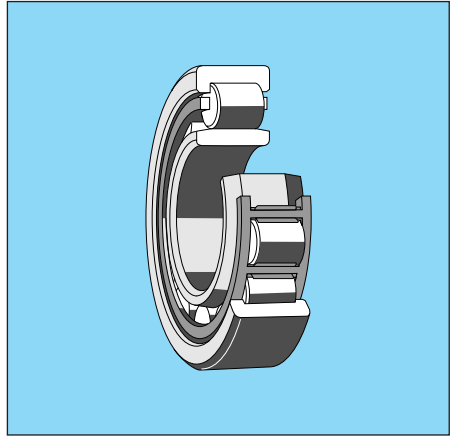

Tolerances

SKF single row cylindrical roller bearings are produced to Normal tolerances as standard. The tolerances conform to ISO 492:1994.

Internal clearance

SKF single row cylindrical roller bearings have Normal radial internal clearance as standard. Many sizes are also available with the larger C3 clearance. The clearance limits are as specified in ISO 5753:1991.

Cages

Depending on bearing series and size, SKF single row cylindrical roller bearings incorporate

- a glass fibre reinforced polyamide 6,6 cage,
- a pressed steel cage, or
- a machined brass cage.

Some bearings which normally have a polyamide 6,6 cage or a pressed steel cage can also be supplied with a machined brass cage instead. Bearings with polyamide 6,6 cages can normally be used at temperatures up to +120 °C. For further information see page 30.

Supplementary designations

The suffixes which are frequently used for SKF cylindrical roller bearings are explained in the following.

C2	Radial internal clearance smaller than Normal
C3	Radial internal clearance greater than Normal
E	Optimised internal design, more and/or larger rollers
EC	Optimised internal design, more and/or larger rollers and improved roller/end flange contact
ECJ	EC + J
ECM	EC + M
ECMA	EC + MA
ECMB	EC + MB
ECML	EC + ML
ECMP	EC + MP
ECP	EC + P
J	Pressed steel cage
M	Machined brass cage, two-part, roller centred

MA	Machined brass cage, two-part, outer ring centred
MB	Machined brass cage, two-part, inner ring centred
ML	Optimised form-turned brass window-type cage, inner or outer ring centred
MP	Brass window-type cage (with pierced, milled or reamed pockets), inner or outer ring centred
P	Injection moulded glass fibre reinforced polyamide 6,6 cage

Cylindrical roller bearings

single row

d 15–45 mm

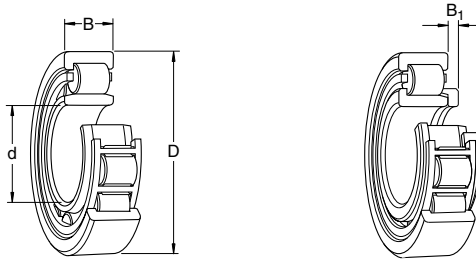

Dimensions				Basic load rating dynamic C	Mass kg	Designations Type		NUP	N	Angle ring HJ
d	D	B	B ₁			NU	NJ			
mm				kN	kg	–				
15	35	11	–	12,5	0,047	NU 202 ECP	NJ 202 ECP	–	–	–
17	40	12	–	17,2	0,068	NU 203 ECP	NJ 203 ECP	NUP 203 ECP	N 203 ECP	–
	40	16	–	23,8	0,092	NU 2203 ECP	NJ 2203 ECP	NUP 2203 ECP	–	–
	47	14	–	24,6	0,12	NU 303 ECP	NJ 303 ECP	–	–	–
20	47	14	–	25,1	0,11	NU 204 ECP	NJ 204 ECP	NUP 204 ECP	N 204 ECP	–
	47	18	–	29,7	0,14	NU 2204 ECP	NJ 2204 ECP	–	–	–
20	52	15	4	30,8	0,15	NU 304 ECP	NJ 304 ECP	NUP 304 ECP	N 304 ECP	HJ 304 EC
	52	21	–	43,1	0,21	NU 2304 ECP	NJ 2304 ECP	–	–	–
25	52	15	3	28,6	0,13	NU 205 ECP	NJ 205 ECP	NUP 205 ECP	N 205 ECP	HJ 205 EC
	52	18	3	34,1	0,16	NU 2205 ECP	NJ 2205 ECP	NUP 2205 ECP	–	HJ 2205 EC
	62	17	4	40,2	0,24	NU 305 ECP	NJ 305 ECP	NUP 305 ECP	N 305 ECP	HJ 305 EC
25	62	24	4	56,1	0,25	NU 2305 ECP	NJ 2305 ECP	–	–	HJ 2305 EC
	62	24	4	56,1	0,36	–	NJ 2305 ECJ	–	–	HJ 2305 EC
	62	24	4	56,1	0,36	–	–	–	–	–
30	55	13	–	17,9	0,12	NU 1006	–	–	–	–
	62	16	4	38	0,20	NU 206 ECP	NJ 206 ECP	NUP 206 ECP	N 206 ECP	HJ 206 EC
	62	20	–	48,4	0,26	NU 2206 ECP	NJ 2206 ECP	NUP 2206 ECP	–	–
30	72	19	5	51,2	0,36	NU 306 ECP	NJ 306 ECP	NUP 306 ECP	N 306 ECP	HJ 306 EC
	72	19	5	51,2	0,37	NU 306 ECJ	–	–	–	HJ 306 EC
	72	27	–	73,7	0,53	NU 2306 ECP	NJ 2306 ECP	–	–	–
	72	27	–	73,7	0,54	–	NJ 2306 ECJ	–	–	–
	72	27	–	73,7	0,54	–	–	–	–	–
35	72	17	4	48,4	0,30	NU 207 ECP	NJ 207 ECP	NUP 207 ECP	N 207 ECP	HJ 207 EC
	72	23	–	59,4	0,40	NU 2207 ECP	NJ 2207 ECP	NUP 2207 ECP	–	–
	80	21	6	64,4	0,48	NU 307 ECP	NJ 307 ECP	NUP 307 ECP	N 307 ECP	HJ 307 EC
35	80	21	6	64,4	0,49	NU 307 ECJ	–	–	–	HJ 307 EC
	80	31	–	91,3	0,73	NU 2307 ECP	NJ 2307 ECP	NUP 2307 ECP	–	–
	80	31	–	91,3	0,73	–	–	–	–	–
40	68	15	–	25,1	0,22	NU 1008 MP	–	–	–	–
	80	18	5	53,9	0,37	NU 208 ECP	NJ 208 ECP	NUP 208 ECP	N 208 ECP	HJ 208 EC
	80	18	5	53,9	0,39	–	NJ 208 ECJ	NUP 208 ECM	–	HJ 208 EC
40	80	23	5	70,4	0,49	NU 2208 ECP	NJ 2208 ECP	NUP 2208 ECP	–	HJ 2208 EC
	80	23	5	70,4	0,51	–	NJ 2208 ECJ	–	–	HJ 2208 EC
	90	23	7	80,9	0,65	NU 308 ECP	NJ 308 ECP	NUP 308 ECP	N 308 ECP	HJ 308 EC
40	90	23	7	80,9	0,66	NU 308 ECJ	NJ 308 ECJ	–	–	HJ 308 EC
	90	33	–	112	0,94	NU 2308 ECP	NJ 2308 ECP	NUP 2308 ECP	–	–
	90	33	–	112	0,95	NU 2308 ECJ	NJ 2308 ECJ	–	–	–
	90	33	–	112	0,95	–	–	–	–	–
	90	33	–	112	0,95	–	–	–	–	–
45	85	19	5	60,5	0,43	NU 209 ECP	NJ 209 ECP	NUP 209 ECP	N 209 ECP	HJ 209 EC
	85	19	5	60,5	0,44	NU 209 ECJ	–	–	–	HJ 209 EC
	85	23	–	73,7	0,52	NU 2209 ECP	NJ 2209 ECP	NUP 2209 ECP	–	–
	85	23	–	73,7	0,53	NU 2209 ECJ	NJ 2209 ECJ	–	–	–

Cylindrical roller bearings

single row

d 45–75 mm

Dimensions				Basic load rating dynamic C	Mass	Designations				Angle ring HJ	
d	D	B	B ₁			Type	NU	NJ	NUP		N
mm				kN	kg	–					
45 (cont.)	100	25	7	99	0,90	NU 309 ECP	NJ 309 ECP	NUP 309 ECP	N 309 ECP	HJ 309 EC	
	100	25	7	99	0,92	NU 309 ECJ	NJ 309 ECJ	NUP 309 ECJ	–	HJ 309 EC	
	100	36	–	138	1,30	NU 2309 ECP	NJ 2309 ECP	NUP 2309 ECP	–	–	
50	80	16	–	30,8	0,31	NU 1010 MP	–	–	–	–	
	90	20	5	64,4	0,48	NU 210 ECP	NJ 210 ECP	NUP 210 ECP	N 210 ECP	HJ 210 EC	
	90	20	5	64,4	0,48	NU 210 ECJ	NJ 210 ECJ	–	–	HJ 210 EC	
	90	23	–	78,1	0,56	NU 2210 ECP	NJ 2210 ECP	NUP 2210 ECP	–	–	
	90	23	–	78,1	0,58	–	NJ 2210 ECJ	NUP 2210 ECJ	–	–	
	110	27	8	110	1,15	NU 310 ECP	NJ 310 ECP	NUP 310 ECP	N 310 ECP	HJ 310 EC	
	110	27	8	110	1,15	NU 310 ECJ	NJ 310 ECJ	NUP 310 ECJ	–	HJ 310 EC	
55	110	40	–	161	1,70	NU 2310 ECP	NJ 2310 ECP	NUP 2310 ECP	–	–	
	110	40	–	161	2,00	NU 2310 ECML	–	–	–	–	
	100	21	6	84,2	0,66	NU 211 ECP	NJ 211 ECP	NUP 211 ECP	N 211 ECP	HJ 211 EC	
60	100	21	6	84,2	0,67	–	NJ 211 ECJ	NUP 211 ECJ	–	HJ 211 EC	
	100	25	6	99	0,79	NU 2211 ECP	NJ 2211 ECP	NUP 2211 ECP	–	HJ 2211 EC	
	120	29	9	138	1,45	NU 311 ECP	NJ 311 ECP	NUP 311 ECP	N 311 ECP	HJ 311 EC	
	120	29	9	138	1,45	NU 311 ECJ	NJ 311 ECJ	–	–	HJ 311 EC	
	120	43	9	201	2,20	NU 2311 ECP	NJ 2311 ECP	NUP 2311 ECP	–	HJ 2311 EC	
65	95	18	–	37,4	0,48	NU 1012 MA	–	–	–	–	
	110	22	6	93,5	0,81	NU 212 ECP	NJ 212 ECP	NUP 212 ECP	N 212 ECP	HJ 212 EC	
	110	22	6	93,5	0,81	NU 212 ECJ	NJ 212 ECJ	–	–	HJ 212 EC	
	110	28	6	128	1,10	NU 2212 ECP	NJ 2212 ECP	NUP 2212 ECP	–	HJ 2212 EC	
	110	28	6	128	1,10	NU 2212 ECJ	–	–	–	HJ 2212 EC	
	130	31	9	151	1,80	NU 312 ECP	NJ 312 ECP	NUP 312 ECP	N 312 ECP	HJ 312 EC	
	130	31	9	151	1,80	NU 312 ECJ	NJ 312 ECJ	–	–	HJ 312 EC	
	130	31	9	151	1,80	NU 312 ECM	–	–	–	HJ 312 EC	
	130	46	–	224	2,75	NU 2312 ECP	NJ 2312 ECP	NUP 2312 ECP	–	–	
	130	46	–	224	3,15	–	NJ 2312 ECML	–	–	–	
65	100	18	–	38	0,51	NU 1013 MA	–	–	–	–	
	120	23	6	106	1,05	NU 213 ECP	NJ 213 ECP	NUP 213 ECP	N 213 ECP	HJ 213 EC	
	120	23	6	106	1,05	NU 213 ECJ	–	–	–	HJ 213 EC	
	120	31	6	147	1,40	NU 2213 ECP	NJ 2213 ECP	NUP 2213 ECP	–	HJ 2213 EC	
	120	31	6	147	1,40	NU 2213 ECJ	–	–	–	HJ 2213 EC	
	140	33	10	183	2,25	NU 313 ECP	NJ 313 ECP	NUP 313 ECP	N 313 ECP	HJ 313 EC	
	140	33	10	183	2,25	NU 313 ECJ	NJ 313 ECJ	–	–	HJ 313 EC	
	140	48	–	251	3,30	NU 2313 ECP	NJ 2313 ECP	–	–	–	
	70	110	20	5	56,1	0,70	NU 1014 ML	–	–	–	HJ 1014
		125	24	7	119	1,15	NU 214 ECP	NJ 214 ECP	NUP 214 ECP	N 214 ECP	HJ 214 EC
125		24	7	119	1,15	–	NJ 214 ECJ	–	–	HJ 214 EC	
125		31	–	154	1,50	NU 2214 ECP	NJ 2214 ECP	NUP 2214 ECP	–	–	
150		35	10	205	2,75	NU 314 ECP	NJ 314 ECP	NUP 314 ECP	N 314 ECP	HJ 314 EC	
150		35	10	205	2,75	NU 314 ECJ	NJ 314 ECJ	–	–	HJ 314 EC	
150		35	10	205	3,20	NU 314 ECM	–	–	–	HJ 314 EC	
150		51	10	275	4,00	NU 2314 ECP	NJ 2314 ECP	–	–	HJ 2314 EC	
75	115	20	–	58,3	0,74	NU 1015 ML	–	–	–	–	
	130	25	7	130	1,25	NU 215 ECP	NJ 215 ECP	NUP 215 ECP	N 215 ECP	HJ 215 EC	
	130	25	7	130	1,25	NU 215 ECJ	–	–	–	HJ 215 EC	
	130	31	7	161	1,60	NU 2215 ECP	NJ 2215 ECP	NUP 2215 ECP	–	–	
	130	31	7	161	1,60	–	NJ 2215 ECJ	–	–	–	



Cylindrical roller bearings
single row
d 75–105 mm

Dimensions				Basic load rating dynamic C	Mass kg	Designations Type				Angle ring HJ	
d	D	B	B ₁			NU	NJ	NUP	N		
mm				kN	kg	–					
75 (cont.)	160	37	11	242	3,30	NU 315 ECP	NJ 315 ECP	NUP 315 ECP	N 315 ECP	HJ 314 EC	
	160	37	11	242	3,80	NU 315 ECM	NJ 315 ECJ	–	–	HJ 314 EC	
	160	37	11	330	4,90	NU 2315 ECP	NJ 2315 ECP	–	–	HJ 2315 EC	
80	125	22	–	66	0,90	NU 1016	–	–	–	–	
	140	26	8	138	1,50	NU 216 ECP	NJ 216 ECP	NUP 216 ECP	N 216 ECP	HJ 216 EC	
	140	26	8	138	1,55	NU 216 ECJ	NJ 216 ECJ	–	–	HJ 216 EC	
	140	26	8	138	1,80	NU 216 ECM	–	–	–	HJ 216 EC	
	140	33	8	187	2,00	NU 2216 ECP	NJ 2216 ECP	NUP 2216 ECP	–	HJ 2216 EC	
	140	33	8	187	2,00	NU 2216 ECJ	NJ 2216 ECJ	–	–	HJ 2216 EC	
	170	39	11	260	3,95	NU 316 ECP	NJ 316 ECP	NUP 316 ECP	N 316 ECP	HJ 316 EC	
	170	39	11	260	3,95	NU 316 ECJ	–	–	–	HJ 316 EC	
	170	39	11	260	4,65	NU 316 ECM	–	–	–	HJ 316 EC	
	170	58	11	358	5,85	NU 2316 ECP	NJ 2316 ECP	–	–	HJ 2316 EC	
	85	130	22	–	68,2	1,05	NU 1017 ML	–	–	–	–
150		28	8	165	1,90	NU 217 ECP	NJ 217 ECP	NUP 217 ECP	N 217 ECP	HJ 217 EC	
150		28	8	165	2,15	NU 217 ECJ	NJ 217 ECM	–	–	HJ 217 EC	
150		36	8	216	2,45	NU 2217 ECP	NJ 2217 ECP	NUP 2217 ECP	–	HJ 2217 EC	
150		36	8	216	2,45	NU 2217 ECJ	–	–	–	HJ 2217 EC	
180		41	12	297	4,70	NU 317 ECP	NJ 317 ECP	NUP 317 ECP	N 317 ECP	HJ 317 EC	
180		41	12	297	4,70	NU 317 ECJ	–	–	–	HJ 317 EC	
180		41	12	297	5,40	NU 317 ECM	–	–	–	HJ 317 EC	
180		60	12	396	7,00	NU 2317 ECP	NJ 2317 ECP	–	–	HJ 2317 EC	
90		140	24	–	80,9	1,35	NU 1018 ML	–	–	–	–
	160	30	9	183	2,35	NU 218 ECP	NJ 218 ECP	NUP 218 ECP	N 218 ECP	HJ 218 EC	
	160	30	9	183	2,35	NU 218 ECJ	–	–	–	HJ 218 EC	
	160	40	9	242	3,15	NU 2218 ECP	NJ 2218 ECP	NUP 2218 ECP	–	HJ 2218 EC	
	160	40	9	242	3,15	NU 2218 ECJ	–	–	–	HJ 2218 EC	
	190	43	12	319	5,45	NU 318 ECP	NJ 318 ECP	–	N 318 ECP	HJ 318 EC	
	190	43	12	319	5,45	NU 318 ECJ	NJ 318 ECJ	–	–	HJ 318 EC	
	190	43	12	319	6,30	NU 318 ECM	–	–	–	HJ 318 EC	
	190	64	12	440	8,00	NU 2318 ECP	NJ 2318 ECP	–	–	HJ 2318 EC	
	190	64	12	440	8,00	NU 2318 ECJ	–	–	–	HJ 2318 EC	
	95	145	24	–	84,2	1,40	NU 1019 ML	–	–	–	–
170		32	9	220	2,85	NU 219 ECP	NJ 219 ECP	NUP 219 ECP	N 219 ECP	HJ 219 EC	
170		43	9	286	3,85	NU 2219 ECP	NJ 2219 ECP	–	–	–	
200		45	13	341	6,25	NU 319 ECP	NJ 319 ECP	–	N 319 ECP	HJ 319 EC	
200		45	13	341	6,25	NU 319 ECJ	NJ 319 ECJ	–	–	HJ 319 EC	
200		45	13	341	7,30	NU 319 ECM	–	–	–	HJ 319 EC	
200		67	13	468	9,35	NU 2319 ECP	NJ 2319 ECP	–	–	HJ 2319 EC	
200		67	13	468	9,35	NU 2319 ECJ	NJ 2319 ECJ	–	–	HJ 2319 EC	
100	150	24	–	85,8	1,45	NU 1020 ML	–	–	–	–	
	180	34	10	251	3,45	NU 220 ECP	NJ 220 ECP	NUP 220 ECP	N 220 ECP	HJ 220 EC	
	180	34	10	251	3,45	NU 220 ECJ	NJ 220 ECJ	–	–	HJ 220 EC	
	180	46	10	336	4,75	NU 2220 ECP	NJ 2220 ECP	–	–	HJ 2220 EC	
	215	47	13	391	7,60	NU 320 ECP	–	–	N 320 ECP	HJ 320 EC	
	215	47	13	391	7,60	NU 320 ECJ	NJ 320 ECJ	–	–	HJ 320 EC	
	215	47	13	391	8,95	NU 320 ECM	–	–	–	HJ 320 EC	
	215	73	13	583	12,0	NU 2320 ECP	–	–	–	HJ 2320 EC	
	215	73	13	583	12,0	NU 2320 ECJ	NJ 2320 ECJ	–	–	HJ 2320 EC	
	105	160	26	–	101	1,85	NU 1021 ML	–	–	–	–
		190	36	–	264	4,00	NU 221 ECP	NJ 221 ECP	–	N 221 ECP	–
225		49	–	440	8,75	NU 321 ECP	–	–	N 321 ECP	–	
225		49	–	440	8,75	NU 321 ECJ	NJ 321 ECJ	–	–	–	
225		49	–	440	8,75	NU 321 ECM	–	–	–	–	

Cylindrical roller bearings

single row

d 110–170 mm

Dimensions				Basic load rating dynamic C	Mass kg	Designations Type					Angle ring HJ	
d	D	B	B ₁				NU	NJ	NUP	N		
mm				kN	kg	–						
110	170	28	–	128	2,30	NU 1022 ML	–	–	–	–	–	
	200	38	11	292	4,80	NU 222 ECP	NJ 222 ECP	NUP 222 ECP	N 222 ECP	HJ 222 EC		
	200	38	11	292	4,85	NU 222 ECJ	NJ 222 ECJ	–	–	HJ 222 EC		
	200	53	–	380	6,70	NU 2222 ECP	NJ 2222 ECP	–	–	–		
	200	53	–	380	7,00	NU 2222 ECJ	–	–	–	–		
	200	53	–	380	7,70	NU 2222 ECM	–	–	–	–		
	240	50	14	468	10,5	NU 322 ECP	–	–	N 322 ECP	HJ 322 EC		
	240	50	14	468	10,8	NU 322 ECJ	NJ 322 ECJ	NUP 322 ECJ	–	HJ 322 EC		
	240	50	14	468	12,0	NU 322 ECM	–	–	–	HJ 322 EC		
	240	50	14	468	12,0	NU 322 ECMA	–	–	–	HJ 322 EC		
	240	80	–	682	17,0	NU 2322 ECP	–	–	–	–		
	240	80	–	682	18,7	NU 2322 ECMA	–	–	–	–		
	120	180	28	–	134	2,45	NU 1024 ML	–	–	–	–	
		215	40	11	341	5,75	NU 224 ECP	NJ 224 ECP	–	N 224 ECP	HJ 224 EC	
		215	40	11	341	5,85	NU 224 ECJ	NJ 224 ECJ	–	–	HJ 224 EC	
215		58	11	457	8,30	NU 224 ECP	–	–	–	HJ 224 EC		
215		58	11	457	8,60	NU 224 ECJ	NJ 224 ECJ	–	–	HJ 224 EC		
215		58	11	457	9,70	NU 224 ECMA	–	–	–	HJ 224 EC		
260		55	14	539	13,5	NU 324 ECP	–	–	N 324 ECP	HJ 324 EC/VA301		
260		55	14	539	13,5	NU 324 ECJ	NJ 324 ECJ	–	–	HJ 324 EC/VA301		
260		55	14	539	15,2	NU 324 ECMA	–	–	–	HJ 324 EC/VA301		
260		86	14	792	24,0	NU 2324 ECMA	–	–	–	HJ 2324 EC		
130	200	33	–	165	3,75	NU 1026 ML	–	–	–	–		
	230	40	11	358	6,45	NU 226 ECP	NJ 226 ECP	–	–	HJ 226 EC		
	230	40	11	358	6,75	NU 226 ECJ	NJ 226 ECJ	NUP 226 ECJ	–	HJ 226 EC		
	230	40	11	358	7,60	NU 226 ECMA	–	–	–	HJ 226 EC		
	230	64	11	528	10,5	NU 226 ECP	–	–	–	HJ 226 EC		
	230	64	11	528	12,0	NU 226 ECMA	–	–	–	HJ 226 EC		
	280	58	14	627	16,5	NU 326 ECP	–	–	N 326 ECP	HJ 326 EC/VA301		
	280	58	14	627	18,0	NU 326 ECJ	–	–	–	HJ 326 EC/VA301		
	280	58	14	627	19,0	NU 326 ECM	–	–	–	HJ 326 EC/VA301		
	280	58	14	627	19,0	NU 326 ECMA	–	–	–	HJ 326 EC/VA301		
280	93	14	935	30,0	NU 2326 ECMA	–	–	–	HJ 2326 EC			
140	210	33	–	172	4,05	NU 1028 ML	–	–	–	–		
	250	42	11	391	8,60	NU 228 ECJ	NJ 228 ECJ	NUP 228 ECJ	–	HJ 228 EC		
	250	42	11	391	9,10	NU 228 ECMA	–	–	–	HJ 228 EC		
	250	68	11	572	15,0	NU 2282 ECMA	–	–	–	HJ 2282 EC		
	300	62	15	682	20,5	NU 328 ECJ	–	–	–	HJ 328 EC/VA301		
	300	62	15	682	22,7	NU 328 ECM	–	–	–	HJ 328 EC/VA301		
	225	35	–	194	4,85	NU 1030 MA	–	–	–	–		
150	270	45	12	446	11,0	NU 230 ECJ	NJ 230 ECJ	NUP 230 ECJ	–	HJ 230 EC		
	270	73	12	627	20,0	NU 230 ECM	–	–	–	HJ 230 EC		
	320	65	–	781	27,5	NU 330 ECM	–	–	–	–		
	240	38	10	229	5,95	NU 1032 MA	–	–	–	HJ 1032/VA301		
160	290	48	12	501	15,2	NU 232 ECMA	NJ 232 ECMA	–	–	HJ 232 EC		
	290	80	12	809	24,0	NU 2322 ECMA	–	–	–	HJ 2322 EC		
	340	68	15	880	33,0	NU 332 ECMA	–	–	–	HJ 332 EC/VA301		
170	260	42	11	275	7,90	NU 1034 ML	–	–	–	HJ 1034		
	310	52	12	616	19,0	NU 234 ECMA	NJ 234 ECMA	–	–	HJ 234 EC		
	310	86	–	968	30,0	NU 234 ECMA	–	–	–	–		



Cylindrical roller bearings
single row
d 180–300 mm

Dimensions				Basic load rating dynamic C	Mass	Designations		Angle ring HJ
d	D	B	B ₁			Type		
mm				kN	kg	–		
180	280	46	–	336	10,5	NU 1036 MA	–	–
	320	52	12	627	19,5	NU 236 ECMA	NJ 236 ECMA	HJ 236 EC
	320	86	–	1 010	31,5	NU 2236 ECMA	–	–
	380	75	–	913	45,0	NU 336 ECM	–	–
190	290	46	–	347	11,0	NU 1038 MA	–	–
	340	55	13	693	24,5	–	NJ 238 ECMA	HJ 238 EC
	400	78	18	1 140	50,0	NU 338 ECM	–	HJ 338 EC/VA301
200	310	51	13	380	14,5	NU 1040 MA	–	HJ 1040
	360	58	14	765	28,5	–	NJ 240 ECMA	HJ 240 EC
220	340	56	14	495	19,0	NU 1044 MA	–	HJ 1044/VA301
240	360	56	14	523	20,0	NU 1048 MA	–	HJ 1048
260	400	65	16	627	29,5	NU 1052 MA	–	HJ 1052/VA301
280	420	65	16	660	32,5	NU 1056 MA	–	HJ 1056
300	460	74	–	858	44,0	NU 1060 MA	–	–

Full complement cylindrical roller bearings

Full complement cylindrical roller bearings do not have a cage and therefore incorporate the maximum number of rollers, thus permitting compact bearing arrangements to be made for very heavy loads. Because of the special kinematic conditions, however, full complement bearings cannot be operated at such high speeds as the corresponding caged bearings.

The SKF full complement cylindrical roller bearings have the same optimised internal geometry as the bearings with cage. The logarithmic contact profile of the roller/raceway contact improves stress distribution in the bearing. The optimised bearing surfaces favour lubricant film formation and correct rolling conditions. The “opened” flanges improve the conditions in the roller end/flange contact. The benefits deriving from these features include

- high radial and axial load carrying capacity,
- enhanced operational reliability, and
- long service life.

Range

The SKF popular range of full complement cylindrical roller bearings includes single row as well as double row bearings.

The single row bearings are of series NCF 29 V. These have two integral flanges on the inner ring and one integral flange on the outer ring. A retaining ring at the flangeless side of the outer ring prevents the bearing from coming apart.

The double row bearings of series NNF 50 also belong to the SKF popular range. These bearings have a two-part inner ring which is held together by a retaining ring. The outer ring has an integral central flange and two snap ring grooves are provided in the outside diameter. The bearings are sealed at both sides and filled with a lithium base grease which has good rust inhibiting properties. The operating temperature range is dictated by the seal material and is from -40 to $+80$ °C. Under certain conditions the NNF bearings require no maintenance. If the bearings operate in moist or contaminated environments, however, they should be relubricated periodically.

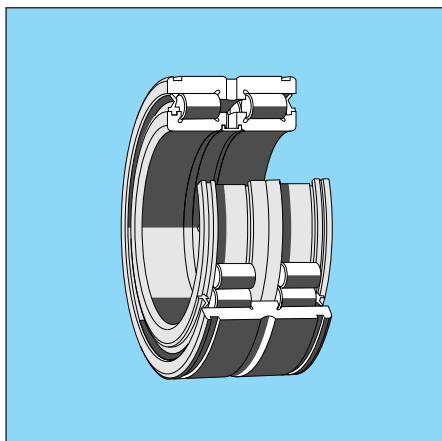
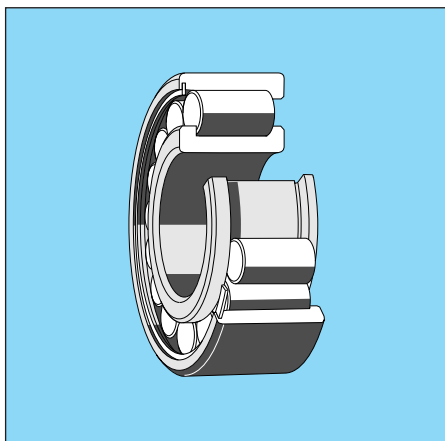

Full complement cylindrical roller bearings

Other single and double row full complement cylindrical roller bearings are also available from SKF. Further information will be supplied on request.

Dimensions

The boundary dimensions of the bearings listed in the tables are in accordance with ISO 15-1981.

The width of the outer ring of series NNF 50 bearings is an exception as it is 1 mm narrower than the inner ring.

Tolerances

SKF full complement cylindrical roller bearings are produced to Normal tolerances as standard. The tolerances conform to ISO 492:1994.

Internal clearance

SKF full complement cylindrical roller bearings have Normal radial internal clearance as standard. They can also be supplied with the larger C3 clearance. Availability should be checked before ordering. The clearance limits are as specified in ISO 5753:1991.

Supplementary designations

The suffixes which are frequently used for SKF full complement cylindrical roller bearings are explained in the following.

A	Extended snap ring grooves in outer ring
ADA	A + DA
C3	Radial internal clearance greater than Normal
C4	Radial internal clearance greater than C3
C5	Radial internal clearance greater than C4
DA	Two-part inner ring held together by retaining ring
H	Self-retaining roller set
-2LS	Polyurethane seal (rubbing seal) at both sides of bearing
-2LSV	2LS + V
V	Full complement bearing (without cage)
VH	V + H

Full complement cylindrical roller bearings single row

d 60–300 mm

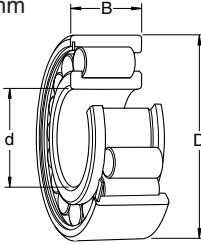

Full complement cylindrical roller bearings double row

d 25–140 mm

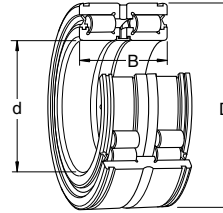

Dimensions			Basic load rating dynamic C	Mass	Designation
d	D	B			
mm			kN	kg	–
60	85	16	53,9	0,28	NCF 2912 V
70	100	19	76,5	0,48	NCF 2914 V
80	110	19	80,9	0,53	NCF 2916 V
90	125	22	105	0,82	NCF 2918 V
100	140	24	132	1,15	NCF 2920 V
110	150	24	140	1,25	NCF 2922 V
120	165	27	172	1,70	NCF 2924 V
130	180	30	205	2,30	NCF 2926 V
140	190	30	220	2,40	NCF 2928 V
150	210	36	286	3,85	NCF 2930 V
160	220	36	297	4,05	NCF 2932 V
170	230	36	308	4,25	NCF 2934 V
180	250	42	391	6,25	NCF 2936 V
190	260	42	440	6,55	NCF 2938 V
200	280	48	528	9,15	NCF 2940 V
220	300	48	512	9,90	NCF 2944 V
240	320	48	583	11,0	NCF 2948 V
260	360	60	737	18,5	NCF 2952 V
280	380	60	897	20,0	NCF 2956 V
300	420	72	1 120	31,5	NCF 2960 V

Dimensions			Basic load rating dynamic C	Mass	Designation
d	D	B			
mm			kN	kg	–
25	47	30	44,6	0,23	NNF 5005 ADA-2LSV
30	55	34	52,8	0,35	NNF 5006 ADA-2LSV
35	62	36	66,0	0,45	NNF 5007 ADA-2LSV
40	68	38	79,2	0,53	NNF 5008 ADA-2LSV
45	75	40	95,2	0,68	NNF 5009 ADA-2LSV
50	80	40	101	0,73	NNF 5010 ADA-2LSV
55	90	46	119	1,10	NNF 5011 ADA-2LSV
60	95	46	123	1,20	NNF 5012 ADA-2LSV
65	100	46	128	1,30	NNF 5013 ADA-2LSV
70	110	54	190	1,85	NNF 5014 ADA-2LSV
75	115	54	201	2,00	NNF 5015 ADA-2LSV
80	125	60	233	2,70	NNF 5016 ADA-2LSV
85	130	60	251	2,75	NNF 5017 ADA-2LSV
90	140	67	297	3,80	NNF 5018 ADA-2LSV
100	150	67	308	4,05	NNF 5020 ADA-2LSV
110	170	80	380	6,45	NNF 5022 ADA-2LSV
120	180	80	402	6,90	NNF 5024 ADA-2LSV
130	200	95	572	10,5	NNF 5026 ADA-2LSV
140	210	95	594	11,0	NNF 5028 ADA-2LSV

Drawn cup needle roller bearings

As the name suggests, drawn cup needle roller bearings have a deep drawn, relatively thin outer ring. Their main characteristics are their very low cross sectional height and high load carrying capacity. They must be mounted with an interference fit in the housing bore.

Two designs are available: one which is open at both sides and one with a closed end intended for shaft ends. The profiled form of the closed end allows small axial guidance forces to be accommodated.

The outer ring of hardened steel sheet and the needle roller and cage assembly of SKF drawn cup needle roller bearings form a non-separable unit. The needle rollers have a modified profile so that damaging edge stresses are avoided. There is adequate free space for lubricant so that long relubrication intervals can be achieved.

Range

Sealed drawn cup needle roller bearings have rubbing seals of polyurethane or synthetic rubber and are filled with a lithium base grease having good rust inhibiting properties. They can be used at temperatures from -20 to $+100$ °C.

SKF can also supply other sizes of drawn cup needle roller bearings with or without seals. Further information will be supplied on request.

Dimensions

The boundary dimensions of the drawn cup needle roller bearings listed in the table are in accordance with ISO 3245-1974.

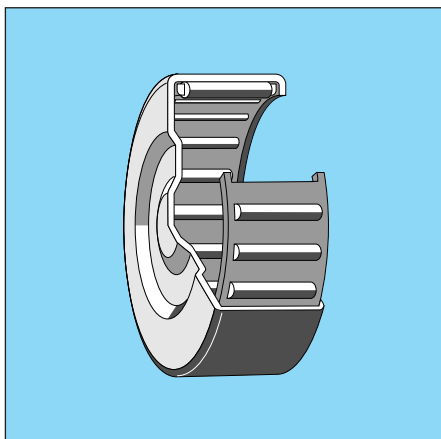
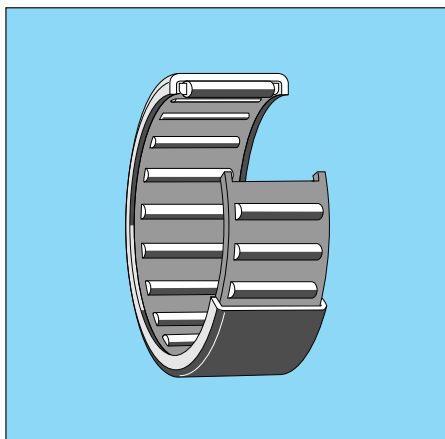

Tolerances

The tolerance for the diameter F_w – the diameter inside the roller set when the rollers are in contact with the outer ring – will be F7 when the bearing is mounted.

Cages

SKF drawn cup needle roller bearings incorporate

- a steel or pressed steel cage, or
- a glass fibre reinforced polyamide 6,6 cage.

Bearings with polyamide cages can normally be used at temperatures up to +120 °C. For further information, see page 30.

Supplementary designations

The suffixes which are frequently used for SKF drawn cup needle roller bearings are explained in the following.

- AS1** Lubrication hole in outer ring
- RS** Polyurethane or synthetic rubber seal (rubbing seal) at one side of bearing
- .2RS** RS seal at both sides of bearing
- TN** Injection moulded glass fibre reinforced polyamide 6,6 cage

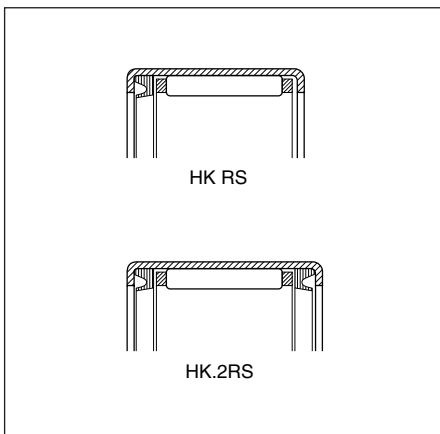

Drawn cup needle roller bearings

F_w 3–60 mm

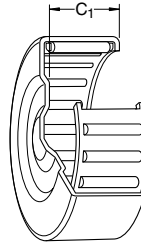
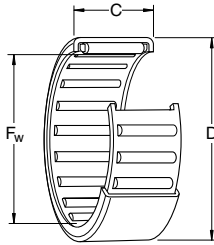

Dimensions			Basic load rating dynamic C	Mass g	Designation Open ends (HK) Closed end (BK)
F _w	D	C/C ₁			
mm			kN		–
3	6,5	6	1,23	1,0	HK 0306 TN
4	8	8	1,72	1,6	HK 0408
	8	8/6,4	1,72	1,8	BK 0408
5	9	9	2,38	2,0	HK 0509
	9	9/7,2	2,38	2,1	BK 0509
6	10	8	2,01	2,1	HK 0608
	10	9	2,81	2,5	HK 0609
	10	9/7,4	2,81	2,6	BK 0609
7	11	9	3,03	2,6	HK 0709
	11	9/7,4	3,03	2,9	BK 0709
8	12	8	2,70	2,7	HK 0808
	12	10	3,69	3,0	HK 0810
	12	12	2,70	3,5	HK 0812.2RS
9	13	8	3,80	3,0	HK 0908
10	14	10	4,29	4,1	HK 1010
	14	12	5,39	4,8	HK 1012
	14	15	6,60	6,0	HK 1015
12	16	10	4,84	4,6	HK 1210
	18	12	6,27	9,1	HK 1212
	18	14	6,27	11	HK 1214 RS
	18	16	6,27	11,5	HK 1216.2RS
13	19	12	6,60	9,5	HK 1312
14	20	12	6,82	10,5	HK 1412
	20	12	6,82	10,5	HK 1412
15	21	12	7,65	11	HK 1512
	21	16	10,1	15	HK 1516
16	22	12	7,37	12	HK 1612
	22	14	7,37	13,5	HK 1614 RS
	22	16	10,5	16	HK 1616
	22	20	11,0	17	HK 1620.2RS
	22	22	12,8	22	HK 1622
17	23	12	7,65	12	HK 1712
18	24	12	7,92	13	HK 1812
	24	16	11,2	18	HK 1816
20	26	10	6,16	12	HK 2010
	26	12	8,42	14	HK 2012
	26	16	12,3	19	HK 2016
	26	18	12,3	21,5	HK 2018 RS
	26	20	15,1	24	HK 2020
	26	30	20,9	35	HK 2030

Dimensions			Basic load rating dynamic C	Mass g	Designation Open ends (HK)
F _w	D	C			
mm			kN		–
22	28	12	8,80	15	HK 2212
	28	16	13,0	21	HK 2216
	28	18	13,0	23,5	HK 2218 RS
	28	20	15,7	26	HK 2220
25	32	16	15,1	27	HK 2516
	32	20	19,0	34	HK 2520
	32	20	15,1	33	HK 2520.2RS
	32	26	24,2	45	HK 2526
28	35	16	15,7	30	HK 2816
	35	20	20,1	38	HK 2820
30	37	12	11,7	24	HK 3012
	37	16	16,5	32	HK 3016
	37	20	20,9	40	HK 3020
	37	26	27,0	53	HK 3026
37	37	38	35,8	76	HK 3038
	37	38	35,8	76	HK 3038
35	42	16	17,9	37	HK 3516
	42	18	17,9	37,5	HK 3518 RS
	42	20	22,9	46	HK 3520
	42	20	17,9	41	HK 3520.2RS
40	47	16	19,0	42	HK 4016
	47	18	19,0	47	HK 4018 RS
	47	20	24,2	52	HK 4020
45	52	16	20,5	46	HK 4516
	52	20	26,0	58	HK 4520
50	58	25	36,9	90	HK 5025
55	63	20	30,3	110	HK 5520
60	68	20	31,9	135	HK 6020

Needle roller bearings

Needle roller bearings are very low section bearings with relatively high load carrying capacity. They may be used with or without inner ring.

Needle roller bearings without inner ring provide the optimum bearing arrangement where shafts can be hardened and ground.

Needle roller bearings with inner ring are used where it is not possible, or not economically viable, to harden and grind the shaft. They permit axial displacement within the bearing.

SKF needle roller bearings are available in several designs and sizes. All the bearings have needle rollers with modified profile so that damaging edge stresses are avoided.

Range

SKF needle roller bearings having an outside diameter of up to and including 19 mm have flanges in the outer ring which are either integral, or take the form of inserted rings. All the larger bearings have integral flanges and an annular groove and one lubrication hole in the outer ring. They are available in single and double row designs. The

double row bearings of series (R)NA 69 having an outside diameter of 55 mm and above have three integral flanges in the outer ring. These guide the two roller sets.

The sealed bearings have synthetic rubber seals. They are filled with a lithium base grease as standard. The grease has good rust inhibiting properties and the bearings can be used at operating temperatures between -20 and $+100$ °C. The inner rings of the sealed bearings are 1 mm wider than the outer rings and they have a lubrication hole.

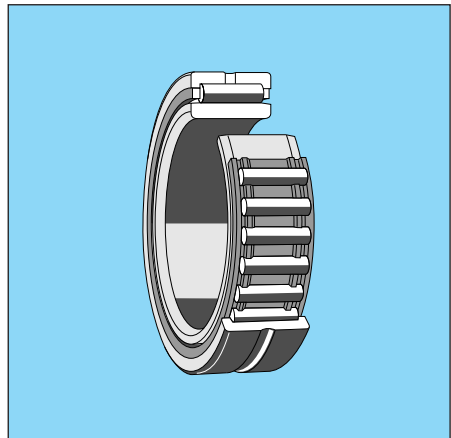
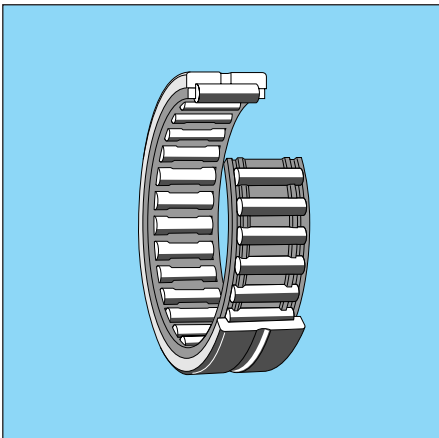

Needle roller bearings

Dimensions

The boundary dimensions of bearings of the NA design are in accordance with ISO 15-1981. Bearings of the RNA design are without inner ring but are otherwise dimensionally equivalent to the corresponding NA design bearings. The other bearings listed in the tables are common industrial sizes.

Tolerances

SKF needle roller bearings are produced to Normal tolerances as standard. The tolerances conform to ISO 492:1994.

Internal clearance

SKF needle roller bearings have Normal radial internal clearance as standard. The clearance limits are as specified in ISO 5373:1991.

Cages

Depending on size, SKF needle roller bearings incorporate

- a steel or pressed steel cage, or
- a glass fibre reinforced polyamide 6,6 cage.

Bearings with polyamide cages can normally be used at temperatures up to +120 °C. For further information see page 30.

Supplementary designations

The suffixes which are frequently used for SKF needle roller bearings are explained in the following.

- RS** Synthetic rubber seal (rubbing seal) at one side of the bearing
- .2RS** RS seal at both sides of bearing
- TN** Injection moulded glass fibre reinforced polyamide 6,6 cage

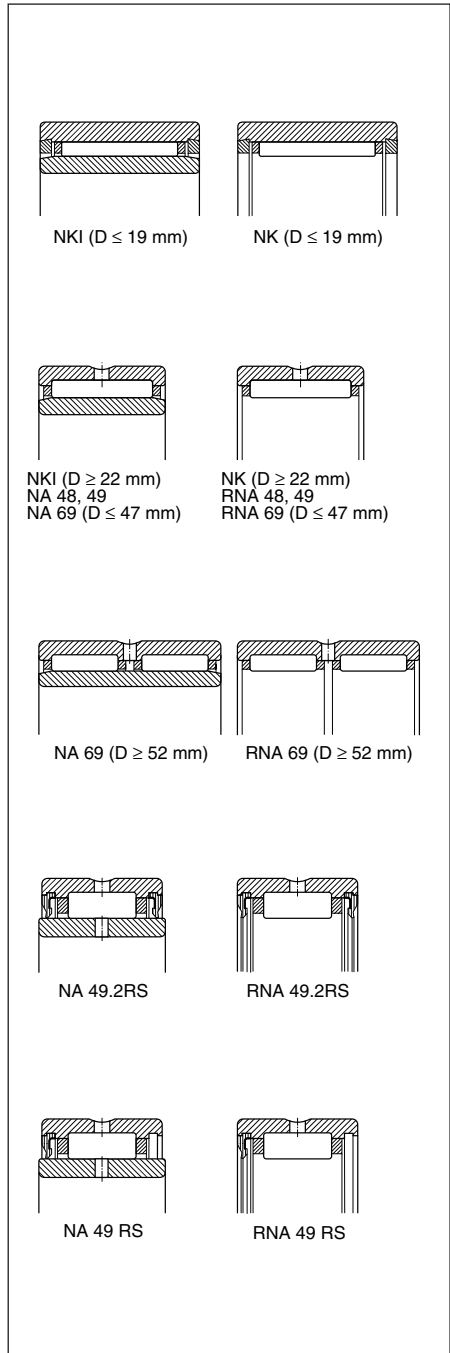

Needle roller bearings with flanges without inner ring

F_w 5–40 mm

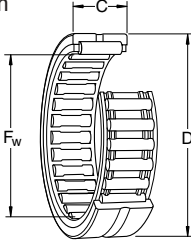

Dimensions				Basic load rating dynamic C	Mass	Designation	Dimensions																		
F _w	D	C					F _w	D	C																
mm			kN	kg	–	mm			kN	kg	–														
5	10	10	2,29	0,003	NK 5/10 TN	24	32	16	15,4	0,032	NK 24/16														
	10	12	2,92	0,005	NK 5/12 TN		32	20	19	0,040	NK 24/20														
6	12	10	2,55	0,005	NK 6/10 TN	25	33	16	15,1	0,033	NK 25/16														
	12	12	3,30	0,006	NK 6/12 TN		33	20	19	0,042	NK 25/20														
7	14	10	2,81	0,007	NK 7/10 TN	37	17	21,6	0,052	RNA 4904															
8	15	12	3,80	0,009	NK 8/12 TN	37	17	19,4	0,056	RNA 4904.2RS															
		16	5,01	0,012	NK 8/16 TN	37	30	35,2	0,10	RNA 6904															
						38	20	27,5	0,068	NKS 25															
9	16	12	4,40	0,010	NK 9/12 TN	26	34	16	15,7	0,034	NK 26/16														
		17	5,94	0,013	NK 10/16 TN		34	20	19,4	0,042	NK 26/20														
12	19	12	6,71	0,014	NK 12/12	28	37	20	22	0,052	NK 28/20														
		16	9,13	0,016	NK 12/16		37	30	31,9	0,082	NK 28/30														
14	22	13	8,80	0,018	RNA 4900	39	17	23,3	0,050	RNA 49/22															
	22	13	7,37	0,016	RNA 4900.2RS	39	30	36,9	0,098	RNA 69/22															
	22	16	10,2	0,021	NK 14/16	42	20	28,6	0,084	NKS 28															
	22	20	12,8	0,026	NK 14/20																				
15	23	16	11	0,022	NK 15/16	29	38	20	22	0,054	NK 29/20														
		20	13,8	0,027	NK 15/20																				
16	24	13	9,90	0,020	RNA 4901	30	40	20	22,9	0,065	NK 30/20														
		13	8,09	0,018	RNA 4901.2RS							40	30	33	0,098	NK 30/30									
		16	11,7	0,022	NK 16/16												42	17	24,2	0,061	RNA 4905				
		20	14,5	0,032	NK 16/20																	42	17	21,6	0,060
22	16,1	0,032	RNA 6901	42	30	38	0,11	RNA 6905																	
17	25	16	12,1						0,024	NK 17/16	32	42	20	23,3	0,068	NK 32/20									
		20	15,1						0,030	NK 17/20							42	30	34,1	0,10	NK 32/30				
18	26	16	12,8						0,025	NK 18/16	47	22	34,1	0,11	NKS 32										
		20	16,1	0,032	NK 18/20																				
19	27	16	13,4	0,026	NK 19/16	35	45	20	24,6	0,074	NK 35/20														
												45	30	35,8	0,11	NK 35/30									
20	28	13	11,2	0,022	RNA 4902	47	17	25,5	0,070	RNA 4906															
		13	9,13	0,022	RNA 4902.2RS						47	17	23,3	0,069	RNA 4906.2RS										
		16	13,2	0,027	NK 20/16											47	30	42,9	0,13	RNA 6906					
		20	16,5	0,034	NK 20/20																50	22	35,2	0,12	NKS 35
		23	17,2	0,040	RNA 6902																				
21	29	16	13,8	0,028	NK 21/16	37	47	20	25,1	0,077															
		20	17,2	0,035	NK 21/20																				
22	30	13	11,4	0,022	RNA 4903	38	48	20	25,5	0,080	NK 38/20														
		13	9,52	0,023	RNA 4903.2RS																				
		16	14,2	0,030	NK 22/16																				
		20	17,9	0,037	NK 22/20																				
		23	18,7	0,042	RNA 6903																				
40	50	20	26,4	0,083	NK 40/20	52	20	30,8	0,090	RNA 49/32															
		30	38	0,13	NK 40/30						52	36	47,3	0,16	RNA 69/32										



Needle roller bearings with flanges without inner ring

F_w 40–165 mm

Dimensions			Basic load rating dynamic C	Mass	Designation
F _w	D	C			
mm			kN	kg	–
40	55	22	38	0,13	NKS 40
42 (cont.)	52	20	27	0,086	NK 42/20
	52	30	39,1	0,13	NK 42/30
	55	20	31,9	0,11	RNA 4907
	55	20	27	0,11	RNA 4907.2RS
	55	36	48,4	0,19	RNA 6907
45	55	20	27,5	0,092	NK 45/20
	55	30	40,2	0,14	NK 45/30
	60	22	40,2	0,15	NKS 45
47	57	20	29,2	0,095	NK 47/20
	57	30	41,8	0,14	NK 47/30
48	62	22	42,9	0,14	RNA 4908
	62	40	67,1	0,26	RNA 6908
50	62	25	38	0,16	NK 50/25
	62	35	49,5	0,22	NK 50/35
	65	22	42,9	0,16	NKS 50
52	68	22	45,7	0,18	RNA 4909
	68	40	70,4	0,34	RNA 6909
55	68	25	40,2	0,18	NK 55/25
	68	35	52,3	0,25	NK 55/35
58	72	22	47,3	0,16	RNA 4910
	72	40	73,7	0,31	RNA 6910
60	72	25	41,8	0,19	NK 60/25
	72	35	55	0,26	NK 60/35
	80	28	62,7	0,34	NKS 60
63	80	25	57,2	0,26	RNA 4911
	80	45	89,7	0,47	RNA 6911
65	78	25	44	0,22	NK 65/25
68	82	25	44	0,24	NK 68/25
	82	35	60,5	0,34	NK 68/35
	85	25	60,5	0,28	RNA 4912
	85	45	93,5	0,49	RNA 6912
70	85	25	44,6	0,26	NK 70/25
	85	35	61,6	0,37	NK 70/35
72	90	25	61,6	0,31	RNA 4913
	90	45	95,2	0,58	RNA 6913
75	92	35	74,8	0,45	NK 75/35
80	95	25	56,1	0,30	NK 80/25
	95	35	76,5	0,43	NK 80/35
	100	30	84,2	0,46	RNA 4914
	100	54	128	0,86	RNA 6914
90	110	25	72,1	0,45	NK 90/25
	110	30	88	0,52	RNA 4916
	110	35	101	0,63	NK 90/35
	110	54	134	1,00	RNA 6916

Dimensions			Basic load rating dynamic C	Mass	Designation
F _w	D	C			
mm			kN	kg	–
100	120	35	108	0,66	RNA 4917
105	125	26	78,1	0,54	NK 105/26
	125	35	112	0,75	RNA 4918
	125	63	172	1,35	RNA 6918
110	130	63	172	1,45	RNA 6919
125	150	40	130	1,25	RNA 4922
130	150	30	99	0,73	RNA 4824
165	190	40	147	1,60	RNA 4830

Needle roller bearings with flanges with inner ring

d 5–45 mm

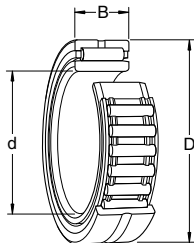

Dimensions			Basic load rating dynamic C	Mass	Designation
d	D	B ¹⁾			
mm			kN	kg	–
5	15	12	3,80	0,012	NKI 5/12 TN
6	16	12	4,40	0,014	NKI 6/12 TN
	16	16	5,72	0,018	NKI 6/16 TN
7	17	12	4,57	0,014	NKI 7/12
9	19	12	6,71	0,017	NKI 9/12
10	22	13	8,80	0,023	NA 4900
	22	13	7,37	0,025	NA 4900.2RS
	22	16	10,2	0,029	NKI 10/16
	22	20	12,8	0,037	NKI 10/20
12	24	13	9,90	0,026	NA 4901
	24	13	8,09	0,028	NA 4901.2RS
	24	16	11,7	0,033	NKI 12/16
	24	20	14,5	0,042	NKI 12/20
	24	20	16,1	0,046	NA 6901
15	27	16	13,4	0,039	NKI 15/16
	27	20	16,5	0,049	NKI 15/20
	28	13	11,2	0,034	NA 4902
28	13	9,13	0,037	NA 4902.2RS	
	23	17,2	0,064	NA 6902	
	17	29	16	13,8	0,043
29	20	17,2	0,054	NKI 17/20	
	30	13	11,4	0,037	NA 4903
30	13	9,52	0,040	NA 4903.2RS	
	23	18,7	0,072	NA 6903	
	37	20	26	0,098	NKIS 17
20	32	16	15,4	0,049	NKI 20/16
	32	20	19	0,061	NKI 20/20
37	17	21,6	0,075	NA 4904	
	17	19,4	0,080	NA 4904.2RS	
	30	35,2	0,14	NA 6904	
42	20	28,6	0,13	NKIS 20	
	22	34	16	15,7	0,052
34	20	19,4	0,065	NKI 22/20	
	25	38	20	22	0,080
38	30	31,9	0,12	NKI 25/30	
	42	17	24,2	0,088	NA 4905
42	17	21,6	0,090	NA 4905.2RS	
	30	38	0,16	NA 6905	

Dimensions			Basic load rating dynamic C	Mass	Designation
d	D	B ¹⁾			
mm			kN	kg	–
25	47	22	34,1	0,16	NKIS 25
	(cont.)	42	20	23,3	0,097
28	42	30	34,1	0,15	NKI 28/30
	30	45	20	24,6	0,11
45	30	35,8	0,17	NKI 30/30	
	47	17	25,5	0,10	NA 4906
47	17	23,3	0,11	NA 4906.2RS	
	30	42,9	0,19	NA 6906	
52	22	36	0,18	NKIS 30	
	32	47	20	25,1	0,12
47	30	36,9	0,18	NKI 32/30	
	52	20	30,8	0,16	NA 49/32
35	50	20	26,4	0,13	NKI 35/20
	30	38,0	0,19	NKI 35/30	
55	20	31,9	0,17	NA 4907	
	20	27,0	0,18	NA 4907 RS	
55	20	27,0	0,18	NA 4907.2RS	
	36	48,4	0,31	NA 6907	
58	22	39,1	0,22	NKIS 35	
	38	53	20	27,5	0,14
53	30	40,2	0,21	NKI 38/30	
	40	55	20	27,5	0,14
55	30	40,2	0,22	NKI 40/30	
	62	22	42,9	0,23	NA 4908
62	22	36,9	0,25	NA 4908.2RS	
	40	67,1	0,43	NA 6908	
65	22	42,9	0,28	NKIS 40	
	42	57	20	29,2	0,15
57	30	41,8	0,22	NKI 42/30	
	45	62	25	38,0	0,23
62	35	49,5	0,32	NKI 45/35	
	68	22	45,7	0,27	NA 4909
68	22	39,1	0,29	NA 4909.2RS	
	40	70,4	0,50	NA 6909	
72	22	44,6	0,34	NKIS 45	

¹⁾ The inner ring of bearings with seal(s) is 1 mm wider than B



Needle roller bearings with flanges with inner ring d 50–190 mm

Dimensions			Basic load rating dynamic C	Mass	Designation
d	D	B ¹⁾			
mm			kN	kg	–
50	68	25	40,2	0,27	NKI 50/25
	68	35	52,3	0,38	NKI 50/35
	72	22	47,3	0,27	NA 4910
	72	22	40,2	0,30	NA 4910.2RS
	72	40	73,7	0,52	NA 6910
	80	28	62,7	0,52	NKIS 50
55	72	25	41,8	0,27	NKI 55/25
	72	35	55,0	0,38	NKI 55/35
	80	25	57,2	0,40	NA 4911
	80	45	89,7	0,78	NA 6911
	85	28	66,0	0,56	NKIS 55
60	82	25	44,0	0,40	NKI 60/25
	82	35	60,5	0,55	NKI 60/35
	85	25	60,5	0,43	NA 4912
	85	45	93,5	0,81	NA 6912
	90	28	68,2	0,56	NKIS 60
65	90	25	61,6	0,46	NA 4913
	90	25	52,8	0,47	NKI 65/25
	90	35	73,7	0,66	NKI 65/35
	90	45	95,2	0,83	NA 6913
70	95	25	56,1	0,52	NKI 70/25
	95	35	76,5	0,74	NKI 70/35
	100	28	74,8	0,68	NKIS 70
	100	30	84,2	0,73	NA 4914
	100	54	128	1,35	NA 6914
75	105	25	69,3	0,64	NKI 75/25
	105	30	84,2	0,78	NA 4915
	105	35	96,8	0,91	NKI 75/35
80	110	25	72,1	0,68	NKI 80/25
	110	30	88,0	0,88	NA 4916
	110	35	101	0,96	NKI 80/35
85	115	26	73,7	0,75	NKI 85/26
	115	36	105	1,05	NKI 85/36
	120	35	108	1,25	NA 4917
90	120	26	76,5	0,78	NKI 90/26
	120	36	108	1,10	NKI 90/36
	125	35	112	1,30	NA 4918
95	125	26	78,1	0,82	NKI 95/26
	125	36	112	1,15	NKI 95/36
	130	35	114	1,40	NA 4919
100	130	30	96,8	1,00	NKI 100/30
	130	40	123	1,35	NKI 100/40
	135	32	91,3	1,35	NKIS 100
	140	40	125	1,90	NA 4920

Dimensions			Basic load rating dynamic C	Mass	Designation
d	D	B			
mm			kN	kg	–
110	140	30	93,5	1,10	NA 4822
120	150	30	99,0	1,15	NA 4824
130	165	35	119	1,80	NA 4826
140	175	35	121	1,95	NA 4828
150	190	40	147	2,70	NA 4830
160	200	40	157	2,90	NA 4832
170	215	45	179	4,00	NA 4834
180	225	45	190	4,20	NA 4836
190	240	50	220	5,60	NA 4838

¹⁾ The inner ring of bearings with seal(s) is 1 mm wider than B

Spherical roller bearings

Spherical roller bearings are self-aligning and therefore insensitive to angular misalignment of the shaft with respect to the housing or to shaft bending in operation. They share this feature with self-aligning ball bearings, but have considerably higher load carrying capacity for both radial and axial loads. Spherical roller bearings are universally applicable bearings for heavy loads.

SKF spherical roller bearings incorporate a large number of long, symmetrical rollers of large diameter and can carry extremely heavy loads. Their internal design represents the latest state of the art. The unique features such as the floating guide ring, special raceway form and optimised bearing surfaces allow SKF spherical roller bearings to

- run at low temperatures and relatively high speeds,
- accommodate relatively heavy axial loads, and
- have long life.

The reliability of SKF spherical roller bearings is exceptional, as is the extensiveness of the range.

Range

SKF spherical roller bearings are produced with cylindrical as well as with tapered bore. The taper is 1:12 except for the wide 240 and 241 series bearings where the taper is 1:30.

SKF also supplies appropriate adapter and withdrawal sleeves to fit the bearings with tapered bore. These enable the bearings to be simply mounted on smooth or stepped shafts, see page 158. Appropriate mounting and dismounting aids, particularly for large-sized bearings, are also available; see page 25.

Dimensions

The boundary dimensions of the bearings listed in the tables are in accordance with ISO 15-1981.

Tolerances

SKF spherical roller bearings are produced to Normal tolerances as standard. The tolerances conform to ISO 492:1994.

Internal clearance

SKF spherical roller bearings have Normal radial internal clearance as standard. They are also available with smaller or larger clearances, but availability should be checked before ordering. The clearance limits are as specified in ISO 5753:1991.

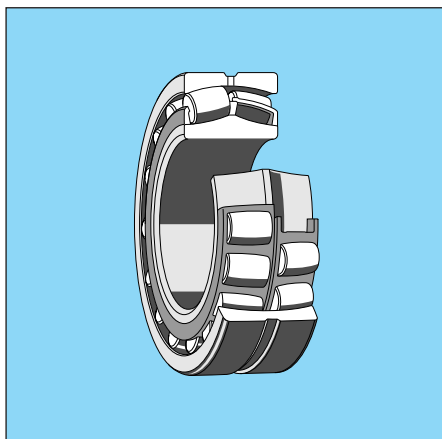

Spherical roller bearings

Designs

Depending on series and size, SKF spherical roller bearings are made to one of the designs shown in the adjacent drawings. The designs are briefly described under "Supplementary designations".

To promote effective lubrication, SKF spherical roller bearings, with a few exceptions, are provided with an annular groove and three lubrication holes in the outer ring (the W33 feature). This feature is standard on bearings of the E design.

Supplementary designations

The suffixes which are frequently used for SKF spherical roller bearings are explained in the following.

CA	Bearing with symmetrical rollers, retaining flanges on the inner ring, a floating guide ring centred on the inner ring between the two rows of rollers, and a machined brass double pronged cage centred on the guide ring
CAC	Bearing of CA design but with special form and finish of the raceways
CACK	CAC + K
CACK30	CAC + K30
CC	Bearing with symmetrical rollers, flangeless inner ring, a floating guide ring centred on the inner ring between the two rows of rollers, and two pressed steel window-type cages. With special form and finish of the raceways
CCJA	CC + JA
CCK	CC + K
CCK30	CC + K30
C2	Radial internal clearance smaller than Normal
C3	Radial internal clearance greater than Normal
C4	Radial internal clearance greater than C3
C5	Radial internal clearance greater than C4

E	Bearing with symmetrical rollers, flangeless inner ring, a guide ring between the two roller rows in which the two pressed steel window-type cages are centred; annular groove and three lubrication holes in the outer ring
EK	E + K
J	Pressed steel window-type cage
JA	Surface hardened pressed steel window-type cage, guided in the outer ring centred guide ring
K	Tapered bore, taper 1:12
K30	Tapered bore, taper 1:30
VA405	Bearing for vibrating machinery
VA406	As VA405 but with PTFE liner in bore
W	Bearing without annular groove and lubrication holes in outer ring
W20	Three lubrication holes in outer ring
W33	Annular groove and three lubrication holes in outer ring

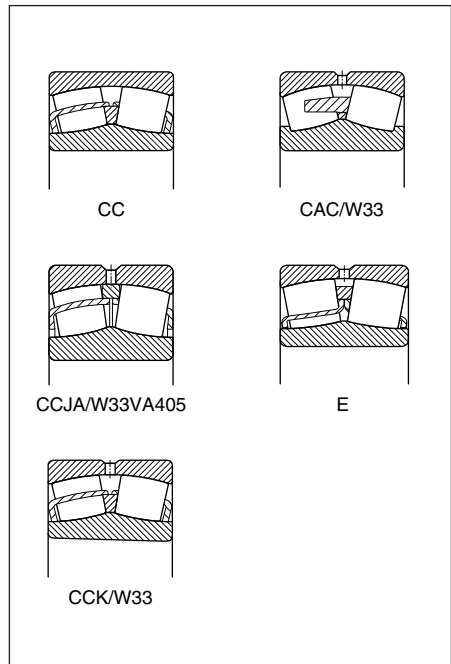

Spherical roller bearings

d 20–65 mm

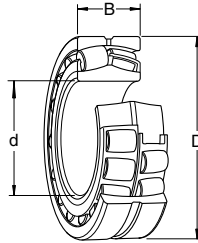

Dimensions			Basic load rating dynamic C	Mass	Designations Bearing with cylindrical bore	tapered bore
d	D	B				
mm			kN	kg	–	
20	52	15	30,5	0,16	21304 CC	–
25	52	18	35,7	0,18	22205 CC	22205 CCK
	52	18	35,7	0,18	22205 CC/W33	–
	62	17	41,4	0,25	21305 CC	–
30	62	20	48,9	0,28	22206 CC	22206 CCK
	62	20	48,9	0,28	22206 CC/W33	–
	72	19	55,2	0,38	21306 CC	–
35	72	23	67,3	0,43	22207 CC	22207 CCK
	72	23	67,3	0,43	22207 CC/W33	22207 CCK/W33
	80	21	65,6	0,51	21307 CC	–
40	80	23	89,7	0,52	22208 E	22208 EK
	90	23	82,8	0,71	21308 CC	21308 CCK
	90	33	127	1,00	22308 E	22308 EK
	90	33	115	1,00	22308 CC	22308 CCK
	90	33	115	1,00	22308 CC/W33	–
45	85	23	77,1	0,56	22209 CC	22209 CCK
	85	23	77,1	0,56	22209 CC/W33	22209 CCK/W33
	100	25	115	0,98	21309 E	21309 EK
	100	36	138	1,35	22309 CC	22309 CCK
	100	36	138	1,35	22309 CC/W33	22309 CCK/W33
50	90	23	97,8	0,60	22210 E	22210 EK
	90	23	84,5	0,60	22210 CC	22210 CCK
	90	23	84,5	0,60	22210 CC/W33	22210 CCK/W33
	110	27	140	1,30	21310 E	21310 EK
	110	40	199	1,85	22310 E	22310 EK
	110	40	176	1,85	22310 CC	22310 CCK
	110	40	176	1,85	22310 CC/W33	22310 CCK/W33
55	100	25	115	0,82	22211 E	22211 EK
	120	29	176	1,65	21311 E	21311 EK
	120	43	235	2,35	22311 E	22311 EK
	120	43	199	2,35	22311 CC/W33A15	22311 CCK/W33A15
60	110	28	140	1,15	22212 E	22212 EK
	130	31	184	2,05	21312 E	21312 EK
	130	46	271	2,90	22312 E	22312 EK
	130	46	235	2,95	22312 CC/W33A15	–
65	120	31	148	1,45	22213 CC	22213 CCK
	120	31	148	1,45	22213 CC/W33	22213 CCK/W33



Spherical roller bearings

d 65–120 mm

Dimensions			Basic load rating dynamic C	Mass	Designations Bearing with cylindrical bore	tapered bore
d	D	B				
mm			kN	kg	–	
65 (cont.)	140	33	207	2,55	21313 E	21313 EK
	140	48	299	3,55	22313 E	22313 EK
	140	48	253	3,55	22313 CC/W33A15	22313 CCK/W33A15
70	125	31	179	1,55	22214 E	22214 EK
	150	35	244	3,15	21314 E	21314 EK
	150	51	345	4,30	22314 E	22314 EK
	150	51	311	4,30	22314 CC/W33A15	–
75	130	31	184	1,70	22215 E	22215 EK
	160	37	244	3,80	21315 E	21315 EK
	160	55	385	5,25	22315 E	22315 EK
	160	55	345	5,25	22315 CCJA/W33VA405	–
80	140	33	207	2,10	22216 E	22216 EK
	170	39	282	4,55	21316 E	21316 EK
	170	58	431	6,20	22316 E	22316 EK
	170	58	374	6,20	22316 CCJA/W33VA405	–
85	150	36	244	2,65	22217 E	22217 EK
	180	41	282	5,35	21317 E	21317 EK
	180	60	477	7,25	22317 E	22317 EK
	180	60	420	7,25	22317 CCJA/W33VA405	–
90	160	40	282	3,40	22218 E	22218 EK
	160	52,4	311	4,60	23218 CC	23218 CCK
	160	52,4	311	4,60	23218 CC/W33	23218 CCK/W33
	190	43	334	6,25	21318 E	21318 EK
	190	64	535	8,60	22318 E	22318 EK
	190	64	477	8,60	22318 CCJA/W33VA405	22318 CCKJA/W33VA405
95	170	43	334	4,15	22219 E	22219 EK
	200	45	368	7,20	21319 E	–
	200	67	587	10,0	22319 E	22319 EK
	200	67	518	10,0	22319 CCJA/W33VA405	–
100	150	50	267	3,20	24020 CC	–
	165	52	322	4,40	23120 CC/W33	–
	180	46	368	4,90	22220 E	22220 EK
	180	60,3	414	6,70	23220 CC/W33	23220 CCK/W33
	215	47	368	8,80	21320 E	21320 EK
	215	73	702	13,0	22320 E	22320 EK
	215	73	610	13,0	22320 CCJA/W33VA405	22320 CCKJA/W33VA405
	215	73	610	13,0	22320 CCJA/W33VA405	22320 CCKJA/W33VA405
110	170	45	267	3,75	23022 CC/W33	–
	180	56	374	5,55	23122 CC/W33	23122 CCK/W33
	180	69	460	6,85	24122 CC/W33	24122 CCK30/W33
	200	53	489	7,00	22222 E	22222 EK
	200	69,8	518	9,70	23222 CC/W33	23222 CCK/W33
	240	80	828	17,5	22322 E	22322 EK
	240	80	725	18,0	22322 CCJA/W33VA405	22322 CCKJA/W33VA405
	240	80	725	18,0	22322 CCJA/W33VA405	22322 CCKJA/W33VA405
120	180	46	305	4,20	23024 CC/W33	23024 CCK/W33
	180	60	374	5,40	24024 CC/W33	–
	200	62	449	7,80	23124 CC/W33	23124 CCK/W33
	200	80	575	10,0	24124 CC/W33	24124 CCK30/W33
	200	80	575	10,0	24124 CC/W33	24124 CCK30/W33

Spherical roller bearings

d 120–170 mm

Dimensions			Basic load rating dynamic C	Mass	Designations Bearing with cylindrical bore	tapered bore
d	D	B				
mm			kN	kg	–	
120 (cont.)	215	58	552	8,85	22224 E	22224 EK
	215	76	610	12,0	23224 CC/W33	23224 CCK/W33
	260	86	845	22,0	22324 CC/W33	22324 CCK/W33
	260	86	845	22,0	22324 CCJA/W33VA405	22324 CCKJA/W33VA405
130	200	52	374	6,10	23026 CC/W33	23026 CCK/W33
	200	69	477	7,95	24026 CC/W33	–
	210	64	489	8,55	23126 CC/W33	23126 CCK/W33
	210	80	587	11,0	24126 CC/W33	24126 CCK30/W33
	230	64	644	11,0	22226 E	22226 EK
	230	80	690	14,0	23226 CC/W33	23226 CCK/W33
	280	93	978	28,5	22326 CC/W33	22326 CCK/W33
	280	93	978	28,5	22326 CCJA/W33VA405	22326 CCKJA/W33VA405
140	210	53	397	6,55	23028 CC/W33	23028 CCK/W33
	210	69	495	8,45	24028 CC/W33	24028 CCK30/W33
	225	68	546	10,5	23128 CC/W33	23128 CCK/W33
	225	85	673	13,0	24128 CC/W33	24128 CCK30/W33
	250	68	610	14,0	22228 CC/W33	22228 CCK/W33
	250	88	799	18,5	23228 CC/W33	23228 CCK/W33
	300	102	1 130	34,5	22328 CC/W33	22328 CCK/W33
	300	102	1 130	34,5	22328 CCJA/W33VA405	22328 CCKJA/W33VA405
150	225	56	437	7,95	23030 CC/W33	23030 CCK/W33
	225	75	564	10,5	24030 CC/W33	24030 CCK30/W33
	250	80	725	16,0	23130 CC/W33	23130 CCK/W33
	250	100	897	19,5	24130 CC/W33	24130 CCK30/W33
	270	73	736	18,0	22230 CC/W33	22230 CCK/W33
	270	96	937	24,0	23230 CC/W33	23230 CCK/W33
	320	108	1 270	41,5	22330 CC/W33	22330 CCK/W33
	320	108	1 270	41,5	22330 CCJA/W33VA405	–
160	240	60	506	9,70	23032 CC/W33	23032 CCK/W33
	240	80	656	13,0	24032 CC/W33	24032 CCK30/W33
	270	86	845	20,5	23132 CC/W33	23132 CCK/W33
	270	109	1 040	25,0	24132 CC/W33	24132 CCK30/W33
	290	80	863	22,5	22232 CC/W33	22232 CCK/W33
	290	104	1 070	30,0	23232 CC/W33	23232 CCK/W33
	340	114	1 380	50,0	22332 CC/W33	22332 CCK/W33
	340	114	1 380	50,0	22332 CCJA/W33VA405	–
170	260	67	621	13,0	23034 CC/W33	23034 CCK/W33
	260	90	799	17,5	24034 CC/W33	24034 CCK30/W33
	280	88	897	21,5	23134 CC/W33	23134 CCK/W33
	280	109	1 070	26,5	24134 CC/W33	24134 CCK30/W33
	310	86	978	28,5	22234 CC/W33	22234 CCK/W33
	310	110	1 220	36,5	23234 CC/W33	23234 CCK/W33
	360	120	1 540	58,5	22334 CC/W33	22334 CCK/W33
	360	120	1 540	58,5	22334 CCJA/W33VA405	–

Spherical roller bearings
d 180–240 mm

Dimensions			Basic load rating dynamic C	Mass	Designations Bearing with cylindrical bore	tapered bore	
d	D	B					
mm			kN	kg	–		
180	250	52	431	8,20	23936 CC/W33	–	
	280	74	725	17,0	23036 CC/W33	23036 CCK/W33	
	280	100	937	23,0	24036 CC/W33	24036 CCK30/W33	
	300	96	1 050	27,5	23136 CC/W33	23136 CCK/W33	
	300	118	1 220	33,5	24136 CC/W33	24136 CCK30/W33	
	320	86	1 010	29,5	22236 CC/W33	22236 CCK/W33	
	320	112	1 290	39,0	23236 CC/W33	23236 CCK/W33	
	380	126	1 730	69,0	22336 CC/W33	22336 CCK/W33	
	380	126	1 730	69,0	22336 CCJA/W33VA405	–	
	190	260	52	414	8,40	23938 CC/W33	–
290		75	753	18,0	23038 CC/W33	23038 CCK/W33	
290		100	978	24,0	24038 CC/W33	24038 CCK30/W33	
320		104	1 200	34,5	23138 CC/W33	23138 CCK/W33	
320		128	1 400	42,0	24138 CC/W33	24138 CCK30/W33	
340		92	1 110	36,5	22238 CC/W33	22238 CCK/W33	
340		120	1 460	47,5	23238 CC/W33	23238 CCK/W33	
400		132	1 870	80,0	22338 CC/W33	22338 CCK/W33	
400		132	1 870	80,0	22338 CCJA/W33VA405	–	
200		280	60	546	11,5	23940 CC/W33	–
	310	82	880	23,0	23040 CC/W33	23040 CCK/W33	
	310	109	1 130	30,5	24040 CC/W33	24040 CCK30/W33	
	340	112	1 380	42,5	23140 CC/W33	23140 CCK/W33	
	340	140	1 580	52,0	24140 CC/W33	24140 CCK30/W33	
	360	98	1 270	43,5	22240 CC/W33	22240 CCK/W33	
	360	128	1 610	57,0	23240 CC/W33	23240 CCK/W33	
	420	138	2 020	92,5	22340 CC/W33	22340 CCK/W33	
	420	138	2 020	92,5	22340 CCJA/W33VA405	–	
	220	300	60	546	13,0	23944 CC/W33	–
340		90	1 050	30,5	23044 CC/W33	23044 CCK/W33	
340		118	1 360	39,5	24044 CC/W33	24044 CCK30/W33	
370		120	1 580	53,0	23144 CC/W33	23144 CCK/W33	
370		150	1 840	65,0	24144 CC/W33	24144 CCK30/W33	
400		108	1 520	60,5	22244 CC/W33	22244 CCK/W33	
400		144	2 070	79,5	23244 CC/W33	23244 CCK/W33	
460		145	2 350	120	22344 CC/W33	22344 CCK/W33	
240		320	60	564	14,0	23948 CC/W33	–
		360	92	1 130	33,5	23048 CC/W33	23048 CCK/W33
	360	118	1 380	42,5	24048 CC/W33	24048 CCK30/W33	
	400	128	1 790	65,5	23148 CC/W33	23148 CCK/W33	
	400	160	2 100	80,5	24148 CC/W33	24148 CCK30/W33	
	440	120	1 910	83,0	22248 CC/W33	22248 CCK/W33	
	440	160	2 530	110	23248 CC/W33	23248 CCK/W33	
	500	155	2 670	155	22348 CC/W33	22348 CCK/W33	

Spherical roller bearings

d 260–420 mm

Dimensions			Basic load rating dynamic C	Mass	Designations Bearing with cylindrical bore	tapered bore
d	D	B				
mm			kN	kg	–	
260	360	75	880	24,0	23952 CC/W33	–
	400	104	1 400	48,5	23052 CC/W33	23052 CCK/W33
	400	140	1 760	64,5	24052 CC/W33	24052 CCK30/W33
	440	144	2 220	90,5	23152 CC/W33	23152 CCK/W33
	440	180	2 620	110	24152 CC/W33	24152 CCK30/W33
	480	174	2 820	140	23252 CAC/W33	23252 CACK/W33
280	380	75	845	26,0	23956 CC/W33	–
	420	106	1 520	52,5	23056 CC/W33	23056 CCK/W33
	420	140	1 870	68,5	24056 CC/W33	24056 CCK30/W33
	460	146	2 300	97,0	23156 CC/W33	23156 CCK/W33
	460	180	2 670	120	24156 CC/W33	24156 CCK30/W33
	500	176	2 820	150	23256 CAC/W33	23256 CACK/W33
300	420	90	1 200	40,5	23960 CC/W33	–
	460	118	1 840	71,5	23060 CC/W33	23060 CCK/W33
	460	160	2 350	97,0	24060 CC/W33	24060 CCK30/W33
	500	160	2 820	125	23160 CC/W33	23160 CCK/W33
320	440	90	1 240	42,0	23964 CAC/W33	–
	480	121	1 960	78,0	23064 CC/W33	23064 CCK/W33
340	460	90	1 270	45,5	23968 CC/W33	–
	520	133	2 350	105	23068 CC/W33	23068 CCK/W33
360	480	90	1 290	46,5	23972 CAC/W33	–
	540	134	2 390	110	23072 CC/W33	23072 CCK/W33
380	520	106	1 730	69,0	23976 CC/W33	–
	560	135	2 480	115	23076 CC/W33	23076 CCK/W33
400	540	106	1 730	71,0	23980 CAC/W33	–
420	560	106	1 760	74,5	23984 CAC/W33	–

Taper roller bearings

Taper roller bearings are designed to be able to take up combined (radial and axial) loads. Single row taper roller bearings can only accept axial loads acting in one direction. They are therefore adjusted against a second bearing which takes axial loads acting in the other direction. The bearings are separable, i.e. the inner ring with roller and cage assembly (cone) can be mounted separately from the outer ring (cup).

SKF taper roller bearings, particularly the TQ-Line bearings, represent the latest state of the art. The roller/raceway contact has the “logarithmic” profile. The optimised internal geometry, including the roller end/flange contact, and bearing surfaces provide the following advantages for SKF taper roller bearings:

- appreciably lower friction,
- increased load carrying capacity,
- reliable adjustment of bearings against each other, and
- appreciably improved operational reliability, even under heavy loads or misalignment.

SKF bearings of the CL7A and CL7C design, for bearing arrangements where axial loads are heavy, e.g. automotive rear axle gears, offer additional benefits. The bearings have high running accuracy and particularly favourable friction characteristics.

Designations

Metric sizes: these designations follow the normal pattern for metric bearings, i.e. they indicate the ISO Dimension Series and bore size.

Inch sizes: these designations follow ANSI-ABMA Standard 19.2-1994). The main difference here is that the bearing series is made up of several cups (outer rings) and cones (inner ring with roller and cage assembly)

which have the same roller and cage assembly. Any cup of a series can be combined with any cone of the same series to form a complete bearing. Because of this the cups and cones have separate designations. The designation of a complete bearing consists of the cone designation followed by the cup designation. The cone designation is separated from the cup designation by an oblique stroke.

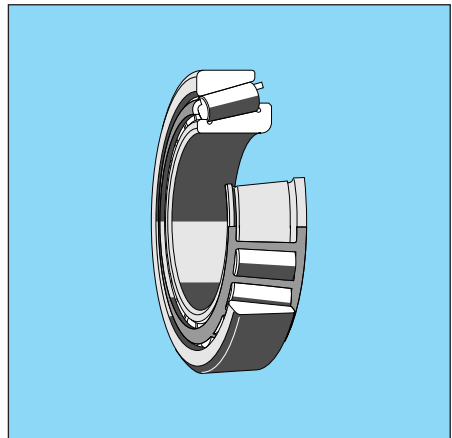

Range

SKF produces single row taper roller bearings in both metric and inch sizes.

In addition to the popular range shown in the tables, the SKF manufacturing programme covers many other taper roller bearings of various types and sizes. These include paired single row taper roller bearings. Further information will be supplied on request.

Dimensions

The boundary dimensions of the metric taper roller bearings listed in the tables are in accordance with ISO 355-1977 and those of the inch-size bearings correspond to ABMA Standard 19-1974.

Tolerances

SKF metric single row taper roller bearings are produced to Normal tolerances as standard. These conform to ISO 492:1994.

SKF inch-size taper roller bearings are produced to Normal tolerances in accordance with ISO 578:1987 and the AFBMA Standard 19-1974, class 4. Cups and cones having a width tolerance which deviates from the Normal are identified by a suffix, e.g. /2 or /3.

The tolerances of bearings to the CL7A and CL7C specifications correspond to Normal tolerances except for the tolerances for the ring width variation and for the radial runout and side face runout. These tolerances are approximately halved.

Cages

All the SKF taper roller bearings listed in this catalogue are fitted with a pressed steel window-type cage.

Supplementary designations

The suffixes which are frequently used for SKF taper roller bearings are explained in the following.

CL7A	Standard pinion bearing execution
CL7B	Special pinion bearing execution
CL7C	New standard pinion bearing execution
J	Pressed steel window-type cage. A figure following the J, e.g. J2, identifies a design which differs from the original
Q	Optimised contact geometry and bearing surfaces
QCL7A	Q + CL7A
QCL7B	Q + CL7B
QCL7C	Q + CL7C
VC027	Special heat and surface treatment
/W	Special ring width tolerance +0,051/0 mm
X	Dimensions changed to conform to ISO
XJ2	X + J2
/2	Special abutment width tolerance of cone assembled with master cup, or cup assembled with master cone +0,051/0 mm
/3	Special abutment width tolerance of cone assembled with master cup, or cup assembled with master cone +0,076/0 mm

Taper roller bearings

single row

d 15–40 mm

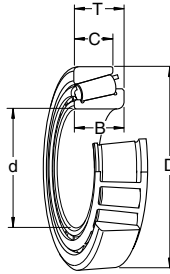

Dimensions					Basic load rating dynamic C	Mass	Designation
d	D	B	C	T			
mm					kN	kg	–
15	42	13	11	14,25	22,4	0,095	30302 J2
17	40	12	11	13,25	19	0,075	30203 J2
	47	14	12	15,25	28,1	0,13	30303 J2
	47	19	16	20,25	34,7	0,17	32303 J2
20	42	15	12	15	24,2	0,097	32004 X
	47	14	12	15,25	27,5	0,12	30204 J2
	52	15	13	16,25	34,1	0,17	30304 J2
	52	21	18	22,25	44	0,23	32304 J2
25	47	15	11,5	15	27	0,11	32005 X
	52	15	13	16,25	30,8	0,15	30205 J2
	62	17	15	18,25	44,6	0,26	30305 J2
	62	17	13	18,25	38	0,26	31305 J2
	62	24	20	25,25	60,5	0,36	32305 J2
28	52	16	12	16	31,9	0,15	320/28 X
30	55	17	13	17	35,8	0,17	32006 X/Q
	62	16	14	17,25	40,2	0,23	30206 J2/Q
	62	20	17	21,25	50,1	0,28	32206 J2
	62	25	19,5	25	64,4	0,37	33206
	72	19	16	20,75	56,1	0,39	30306 J2
	72	19	14	20,75	47,3	0,39	31306 J2/Q
	72	27	23	28,75	76,5	0,55	32306 J2
32	58	17	13	17	36,9	0,19	320/32 X/Q
35	62	18	14	18	42,9	0,22	32007 X
	72	17	15	18,25	51,2	0,32	30207 J2
	72	23	19	24,25	66	0,43	32207 J2/Q
	72	28	22	28	84,2	0,56	33207
	80	21	18	22,75	72,1	0,52	30307 J2
	80	21	15	22,75	61,6	0,52	31307 J2/Q
	80	31	25	32,75	95,2	0,73	32307 J2
40	68	19	14,5	19	52,8	0,27	32008 X/Q
	75	26	20,5	26	79,2	0,51	33108
	80	18	16	19,75	61,6	0,42	30208 J2
	80	23	19	24,75	74,8	0,53	32208 J2
	80	32	25	32	105	0,77	33208 Q

Taper roller bearings

single row

d 40–65 mm

Dimensions					Basic load rating dynamic C	Mass	Designation
d	D	B	C	T			
mm					kN	kg	–
40	90	23	20	25,25	85,8	0,72	30308 J2
	(cont.) 90	23	17	25,25	73,7	0,72	31308 J2/QCL7C
	90	33	27	35,25	117	1,00	32308 J2
45	75	20	15,5	20	58,3	0,34	32009 X/Q
	80	26	20,5	26	84,2	0,56	33109/Q
	85	19	16	20,75	66	0,48	30209 J2
	85	23	19	24,75	80,9	0,58	32209 J2
	85	32	25	32	108	0,82	33209
	100	25	22	27,25	108	0,97	30309 J2
	100	25	18	27,25	91,3	0,95	31309 J2/QCL7A
100	36	30	38,25	140	1,35	32309 J2	
50	80	20	15,5	20	60,5	0,37	32010 X/Q
	80	24	19	24	69,3	0,45	33010
	85	26	20	26	85,8	0,59	33110
	90	20	17	21,75	76,5	0,54	30210 J2
	90	23	19	24,75	82,5	0,61	32210 J2
	90	32	24,5	32	114	0,90	33210/Q
	110	27	23	29,25	125	1,25	30310 J2
110	27	19	29,25	106	1,20	31310 J2/QCL7A	
110	40	33	42,25	172	1,80	32310 J2	
55	90	23	17,5	23	80,9	0,55	32011 X
	90	27	21	27	89,7	0,67	33011
	95	30	23	30	110	0,86	33111/Q
	100	21	18	22,75	89,7	0,70	30211 J2
	100	25	21	26,75	106	0,83	32211 J2
	100	35	27	35	138	1,20	33211/Q
	120	29	25	31,5	142	1,55	30311 J2
120	29	21	31,5	121	1,55	31311 J2/Q	
120	43	35	45,5	198	2,30	32311 J2	
60	95	23	17,5	23	82,5	0,59	32012 X/Q
	95	27	21	27	91,3	0,71	33012
	100	30	23	30	117	0,92	33112
	110	22	19	23,75	99	0,88	30212 J2
	110	28	24	29,75	125	1,15	32212 J2
	110	38	29	38	168	1,60	33212
	130	31	26	33,5	168	1,95	30312 J2/Q
130	31	22	33,5	145	1,90	31312 J2/Q	
130	46	37	48,5	229	2,85	32312 J2	
65	100	23	17,5	23	84,2	0,63	32013 X
	100	27	21	27	96,8	0,78	33013
	110	34	26,5	34	142	1,30	33113
	120	23	20	24,75	114	1,15	30213 J2
	120	31	27	32,75	151	1,50	32213 J2
	120	41	32	41	194	2,05	33213/Q
	140	33	28	36	194	2,40	30313 J2
140	33	23	36	165	2,35	31313 J2/QCL7A	
140	48	39	51	264	3,45	32313 J2	

Taper roller bearings
single row
d 70–95 mm

Dimensions					Basic load rating dynamic C	Mass	Designation	
d	D	B	C	T				
mm					kN	kg	–	
70	110	25	19	25	101	0,84	32014 X/Q	
	110	31	25,5	31	130	1,10	33014	
	120	37	29	37	172	1,70	33114	
	125	24	21	26,25	125	1,25	30214 J2	
	125	31	27	33,25	157	1,60	32214 J2	
	125	41	32	41	201	2,10	33214/Q	
	150	35	30	38	220	2,90	30314 J2	
	150	35	25	38	187	2,95	31314 J2/QCL7A	
	150	51	42	54	297	4,30	32314 J2	
	75	115	25	19	25	106	0,90	32015 X/Q
115		31	25,5	31	134	1,15	33015	
125		37	29	37	176	1,80	33115	
130		25	22	27,25	140	1,40	30215 J2	
130		31	27	33,25	161	1,70	32215 J2	
130		41	31	41	209	2,25	33215/Q	
160		37	31	40	246	3,45	30315 J2	
160		37	26	40	209	3,50	31315 J2	
160		55	45	58	336	5,20	32315 J2	
80		125	29	22	29	138	1,30	32016 X
	125	36	29,5	36	168	1,65	33016	
	130	37	29	37	179	1,90	33116	
	140	26	22	28,25	151	1,60	30216 J2	
	140	33	28	35,25	187	2,05	32216 J2/Q	
	140	46	35	46	251	2,90	33216	
	170	39	33	42,5	270	4,10	30316 J2	
	170	39	27	42,5	224	4,05	31316 J1/QCL7A	
	170	58	48	61,5	380	6,20	32316 J2	
	85	130	29	22	29	140	1,35	32017 X
130		36	29,5	36	183	1,75	33017	
140		41	32	41	220	2,45	33117	
150		28	24	30,5	176	2,05	30217 J2	
150		36	30	38,5	212	2,60	32217 J2	
150		49	37	49	286	3,70	33217	
180		41	34	44,5	303	4,85	30317 J2	
180		41	28	44,5	242	4,60	31317 J2	
180		60	49	63,5	402	6,85	32317 J2	
90		140	32	24	32	168	1,75	32018 X/Q
	140	39	32,5	39	216	2,20	33018	
	150	45	35	45	251	3,10	33118/Q	
	160	30	26	32,5	194	2,55	30218 J2	
	160	40	34	42,5	251	3,35	32218 J2	
	190	43	30	46,5	264	5,90	31318 J2	
	190	64	53	67,5	457	8,40	32318 J2	
	95	145	32	24	32	168	1,80	32019 X
		145	39	32,5	39	220	2,30	33019
		170	32	27	34,5	216	3,00	30219 J2
170		43	37	45,5	281	4,05	32219 J2	

Taper roller bearings

single row

d 95–170 mm

Dimensions					Basic load rating dynamic C	Mass	Designation
d	D	B	C	T			
mm					kN	kg	–
95	200	45	32	49,5	292	6,95	31319 J2
(cont.)	200	67	55	71,5	501	11,0	32319 J2
100	150	32	24	32	172	1,90	32020 X/Q
	150	39	32,5	39	224	2,40	33020
	180	34	29	37	246	3,65	30220 J2
	180	46	39	49	319	4,90	32220 J2
	215	47	39	51,5	402	8,05	30320 J2
	215	73	60	77,5	572	12,5	32320 J2
105	160	35	26	35	201	2,40	32021 X
	190	36	30	39	270	4,25	30221 J2
	190	50	43	53	358	6,00	32221 J2
	225	77	63	81,5	605	14,5	32321 J2
110	170	38	29	38	233	3,05	32022 X
	170	47	37	47	281	3,85	33022
	180	56	43	56	369	5,55	33122
	200	38	32	41	308	5,10	30222 J2
	200	53	46	56	402	7,10	32222 J2
	240	50	42	54,5	473	11,0	30322 J2
	240	80	65	84,5	627	17,0	32322
120	180	38	29	38	242	3,25	32024 X
	180	48	38	48	292	4,20	33024
	215	40	34	43,5	341	6,15	30224 J2
	215	58	50	61,5	468	9,15	32224 J2
	260	55	46	59,4	561	14,0	30324 J2
	260	86	69	90,5	792	21,5	32324 J2
130	180	32	25	32	198	2,40	32926
	200	45	34	45	314	4,95	32026 X
	230	40	34	43,75	369	7,60	30226 J2
	230	64	54	67,75	550	11,5	32226 J2
140	190	32	25	32	205	2,55	32928
	210	45	34	45	330	5,25	32028 X
	250	42	36	45,75	418	8,65	30228 J2
	250	68	58	71,75	644	14,5	32228 J2
150	225	48	36	48	369	6,35	32030 X
	270	45	38	49	429	11,0	30230
	270	73	60	77	737	17,5	32230 J2
160	240	51	38	51	429	7,75	32032 X
	290	48	40	52	528	13,0	30232 J2
	290	80	67	84	880	25,5	32232 J2
170	230	38	30	38	286	4,50	32934
	260	57	43	57	512	10,5	32034 X
	310	86	71	91	1 010	28,5	32234 J2



Taper roller bearings
single row
d 180–280 mm

Dimensions					Basic load rating dynamic C	Mass	Designation
d	D	B	C	T			
mm					kN	kg	–
180	250	45	34	45	352	6,65	32936
	280	64	48	64	644	14,5	32036 X
190	260	45	34	45	358	7,00	32938
	290	64	48	64	660	15,0	32038 X
200	280	51	39	51	473	9,50	32940
	310	70	53	70	748	19,5	32040 X
220	340	76	57	76	897	25,5	32044 X
240	360	76	57	76	935	27,5	32048 X
260	400	87	65	87	1 170	40,0	32052 X
280	420	87	65	87	1 210	40,5	32056 X

Taper roller bearings
single row, inch sizes
d 15,875–45,242 mm

Dimensions					Basic load rating dynamic C	Mass	Designations Cone/cup	Series	
d	D	B	C	T					
mm					kN	kg	–		
15,875	42,862	14,288	9,525	14,288	17,6	0,10	11590/11520	11500	
17,462	39,878	14,605	10,668	13,843	21,2	0,081	LM 11749/LM 11710	LM 11700	
19,050	49,225	21,539	14,288	19,845	39,1	0,19	09074/09195	09000	
21,430	50,005	18,288	13,970	17,526	36,9	0,17	M 12649/M 12610	M 12600	
22,225	52,388	20,168	14,288	19,368	41,8	0,20	1380/1328	1300	
25,400	50,292	14,732	10,668	14,224	26	0,13	L 44643/L 44610	L 44600	
	50,800	14,260	12,700	15,011	28,1	0,13	07100 S/07210 X	07000	
26,988	50,292	14,732	10,668	14,224	26	0,11	L 44649/L 44610	L 44600	
28,575	57,150	19,355	15,875	19,845	47,3	0,20	1988/1922	1900	
	62,000	20,638	14,288	19,050	48,4	0,28	15112/15245	15000	
	63,500	20,638	15,875	20,638	48,4	0,31	15112/15250 X	15000	
	64,292	21,433	16,670	21,433	49,5	0,35	M 86647/M 86610/CL7C	M 86600	
30,162	64,292	21,433	16,670	21,433	49,5	0,33	M 86649/M 86610/CL7C	M 86600	
31,750	59,131	16,764	11,811	15,875	34,7	0,18	LM 67048/LM 67010/Q	LM 67000	
	62,000	19,050	14,288	18,161	48,4	0,24	15123/15243	15000	
	63,500	19,050	15,875	19,749	48,4	0,27	15123/15250 X	15000	
	73,025	27,783	23,020	29,370	70,4	0,62	HM 88542/2/HM 88510/2/QCL7A	HM 88500	
33,338	68,262	22,225	17,462	22,225	55	0,38	M 88048/M 88010/QCL7A	M 88000	
34,925	65,088	18,288	13,970	18,034	47,3	0,25	LM 48548/LM 48510	LM 48500	
	72,233	25,400	19,842	25,400	67,1	0,50	HM 88649/HM 88610/CL7B	HM 88600	
	76,200	28,575	23,020	29,370	78,1	0,66	HM 89446/2/HM 89410/2/QCL7A	HM 89400	
34,988	59,131	16,764	11,938	15,875	33	0,16	L 68149/L 68110/Q	L 68100	
	59,974	16,764	11,938	15,875	33	0,17	L 68149/L 68111/Q	L 68100	
36,487	73,025	24,608	19,050	23,812	72,1	0,45	25880/25820	25800	
36,512	76,200	28,575	23,020	29,370	78,1	0,64	HM 89449/HM 89410/2/QCL7C	HM 89400	
38,100	76,200	25,654	19,050	23,812	74,8	0,50	2788/2720/QCL7A	2700	
	79,375	29,771	23,812	29,370	91,3	0,67	SK-3490/3420/QCL7C	3400	
	82,550	28,575	23,020	29,370	85,8	0,78	HM 801346 X/HM 801310/CL7A	HM 801300	
41,275	73,431	19,812	14,732	19,558	55	0,33	LM 501349/LM 501310/Q	LM 501300	
	82,550	25,654	20,193	26,543	73,7	0,62	M 802048/M 802011/QCL7A	M 802000	
	87,312	30,866	23,812	30,162	102	0,82	3585/3525	3500	
	88,900	29,370	23,020	30,162	95,2	0,90	HM 803146/2/HM 803110/2	HM 803100	
	101,60	36,068	26,988	34,925	151	1,45	526/522	525	
42,875	82,931	25,400	19,050	23,812	80,9	0,57	25577/25520	25500	
	82,931	25,400	22,225	26,988	80,9	0,61	25577/25523	25500	
	83,058	25,400	19,114	23,876	80,9	0,57	25577/25522	25500	
44,450	82,931	25,400	19,050	23,812	80,9	0,57	25580/25520	25500	
	82,931	25,400	22,225	26,988	80,9	0,61	25580/25523	25500	
	83,058	25,400	19,114	23,876	80,9	0,57	25580/25522	25500	
	88,900	29,370	23,020	30,162	95,2	0,85	HM 803149/2/HM 803110/2	HM 803100	
	95,250	28,300	20,638	30,958	88	0,93	53176/53375	53000	
	95,250	28,300	20,638	30,958	88	0,93	53176/53377	53000	
	95,250	28,300	20,638	30,958	88	0,93	53178/53375	53000	
	95,250	28,300	20,638	30,958	88	0,93	53178/53377	53000	
	95,250	28,575	22,225	30,958	101	1,00	HM 903249/W/HM 903210/CL7A	HM 903200	
	44,988	85,000	21,692	17,462	20,638	70,4	0,50	358 X/354 X	355
		85,000	21,692	17,462	20,638	70,4	0,50	358 X/354 X	355
45,242	73,431	19,812	15,748	19,558	53,9	0,30	LM 102949/LM 102910	LM 102900	

Taper roller bearings
single row, inch sizes
d 45,618–127,000 mm

Dimensions					Basic load rating dynamic C	Mass	Designations Cone/cup	Series
d	D	B	C	T				
mm					kN	kg	–	
45,618	82,931 82,931 83,058	25,400 25,400 25,400	19,050 22,225 19,114	23,812 26,988 23,876	80,9 80,9 80,9	0,55 0,58 0,54	25590/25520 25590/25523 25590/25522	25500 25500 25500
46,038	79,375 85,000	17,462 21,692	13,495 17,462	17,462 20,638	49,5 70,4	0,33 0,49	18690/18620 359 S/354 X	18600 355
50,800	85,000 88,900 93,264 107,950	17,462 22,225 30,302 36,957	13,495 16,513 23,812 28,575	17,462 23,812 30,162 36,512	50,1 76,5 110 151	0,37 0,50 0,84 1,55	18790/18720 368 A/362 A 3780/3720 537/532 X	18700 365 3700 535
57,150	96,838 98,425 112,712 119,985	21,946 21,946 30,162 30,162	15,875 17,826 23,812 26,949	20,886 21,000 30,162 32,750	80,9 80,9 142 142	0,59 0,64 1,45 1,75	387 A/382 A 387 A/382 39580/39520 39580/39528	385 385 39500 39500
60,325	130,175	33,338	23,812	36,512	151	2,10	HM 911245/HM 911210	HM 911200
61,912	146,050 146,050	39,688 39,688	25,400 25,400	41,275 41,275	198 198	3,20 3,20	H 913842/H 913810 H 913843/H 913810	H 913800 H 913800
66,675	112,712 112,712 135,755	30,048 30,162 56,007	23,812 23,812 44,450	30,162 30,162 53,975	123 142 286	1,15 1,20 3,65	3984/3920 39590/39520 6386/K-6320	3900 39500 6300
69,850	112,712 120,000	25,400 29,007	19,050 24,237	25,400 29,795	99 132	0,98 1,35	29675/29620 482/472	29600 475
73,025	112,712	25,400	19,050	25,400	99	0,90	29685/2/29620/3	29600
76,200	133,350	33,338	26,195	33,338	165	1,90	47678/47620	47600
82,550	139,992 146,050	36,098 41,275	28,575 31,750	36,512 41,275	187 220	2,20 2,85	580/572 663/653	575 655
82,750	152,400	41,275	31,750	41,275	220	2,70	665/653	655
90,000	161,925	55,100	42,862	53,975	330	4,75	6581 X/6535	6500
92,075	152,400	36,322	30,162	39,688	194	2,65	598/592 A	595
95,250	152,400 152,400 168,275	36,322 36,322 41,275	30,162 30,162 30,162	39,688 39,688 41,275	194 194 233	2,55 2,55 3,75	594/592 A 594 A/592 A 683/672	595 595 675
99,975	156,975	42,000	34,000	42,000	246	2,90	HM 220149/HM 220110	HM 220100
101,600	168,275	41,275	30,162	41,275	233	3,45	687/672	675
107,950	165,100	36,512	26,988	36,512	209	2,80	56425/56650	56000
114,300	177,800	41,275	30,162	41,275	251	3,50	64450/64700	64000
127,000	182,562	38,100	33,338	39,688	229	3,30	48290/48220	48200

Thrust ball bearings

Thrust ball bearings are produced as single direction and double direction bearings. They are only able to accept axial loads but can be operated at relatively high speeds. The bearings are separable. Mounting is therefore simple as the various bearing components (shaft washer, housing washer, ball and cage) can be installed separately.

The benefits of using SKF thrust ball bearings derive from their

- high running accuracy and
- high load carrying capacity.

Range

SKF thrust ball bearings are in regular production in the following designs:

- single direction bearings (1),
- single direction bearings with sphered housing washer and support washer (2), and
- double direction bearings (3).

The bearings with sphered housing washers and seating washers enable errors of alignment between housing and shaft to be compensated for. Please enquire regarding double direction bearings with sphered housing washers.

Dimensions

The boundary dimensions of the bearings with flat housing washers listed in the tables are in accordance with ISO 104-1979. The dimensions of the bearings with sphered housing washer are according to DIN 711 and DIN 715.

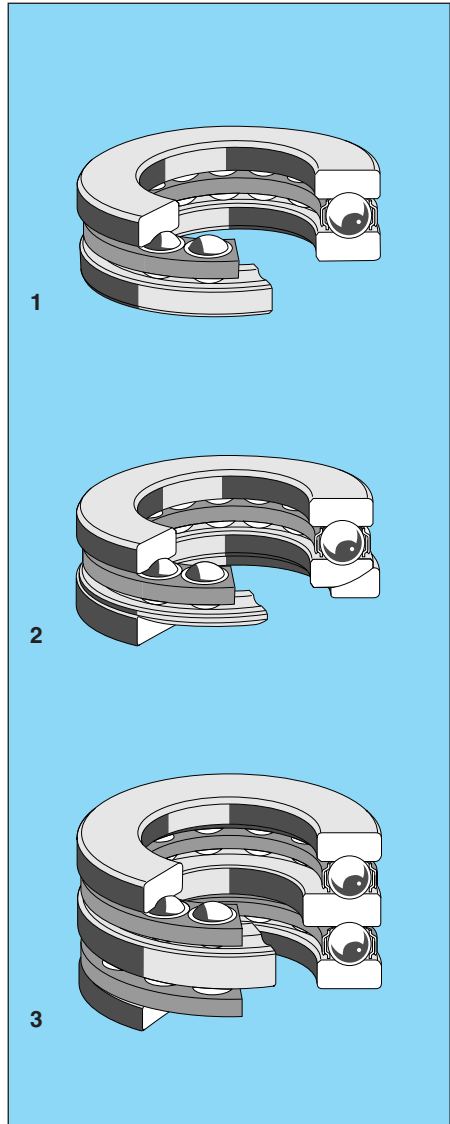

Thrust ball bearings

Tolerances

SKF thrust ball bearings are produced to Normal tolerances as standard. Some sizes are also available with increased accuracy; please check availability. The tolerances conform to ISO 199-1979.

Cages

Depending on bearing series and size, SKF thrust ball bearings incorporate

- a pressed steel cage,
- a machined brass cage, or
- a machined steel cage.

Supplementary designations

The suffixes which are frequently used for SKF thrust ball bearings are explained in the following.

- F** Machined steel cage
- M** Machined brass cage
- P5** Increased dimensional and running accuracy (better than P6) to ISO tolerance class 5
- P6** Increased dimensional and running accuracy (better than Normal) to ISO tolerance class 6

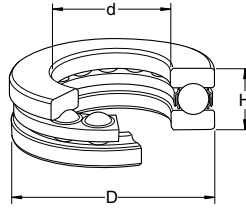

Thrust ball bearings single direction d 3–300 mm

Dimensions					Basic load rating dynamic C	Mass	Designation	Dimensions					
d	D	H						d	D	H			
mm					kN	kg	–	mm					
3	8	3,5			0,852	0,003	BA 3	70	105	27	65,0	0,79	51214
4	10	4			1,25	0,003	BA 4	(cont.)	125	40	135	2,00	51314
6	14	5			1,99	0,004	BA 6	75	100	19	44,2	0,40	51115
7	17	6			2,60	0,005	BA 7		110	27	67,6	0,83	51215
8	19	7			3,32	0,007	BA 8		135	44	163	2,60	51315
10	24	9			9,95	0,020	51100	80	105	19	44,9	0,42	51116
	26	11			12,7	0,031	51200		115	28	76,1	0,91	51216
12	26	9			10,4	0,022	51101		140	44	159	2,70	51316
	28	11			13,3	0,034	51201	85	110	19	46,2	0,44	51117
15	28	9			9,36	0,023	51102		125	31	97,5	1,20	51217
	32	12			16,5	0,046	51202		150	49	190	3,55	51317
17	30	9			9,75	0,025	51103	90	120	22	59,2	0,67	51118
	35	12			17,2	0,053	51203		135	35	119	1,70	51218
20	35	10			12,7	0,038	51104		155	50	195	3,80	51318
	40	14			22,5	0,083	51204	100	135	25	85,2	0,97	51120
25	42	11			15,9	0,056	51105		150	38	124	2,20	51220
	47	15			27,6	0,11	51205		170	55	229	4,95	51320
	52	18			34,5	0,17	51305	110	145	25	87,1	1,05	51122
30	47	11			16,8	0,063	51106		160	38	130	2,40	51222
	52	16			25,5	0,13	51206		190	63	276	7,85	51322 M
	60	21			37,7	0,26	51306	120	155	25	88,4	1,15	51124
	70	28			72,8	0,52	51406		170	39	140	2,65	51224
35	52	12			17,4	0,08	51107		210	70	325	11,0	51324 M
	62	18			35,1	0,22	51207	130	170	30	111	1,85	51126
	68	24			49,4	0,38	51307		190	45	186	4,00	51226
	80	32			87,1	0,76	51407		225	75	358	13,0	51326 M
40	60	13			23,4	0,12	51108	140	180	31	111	2,05	51128
	68	19			46,8	0,28	51208		200	46	190	4,35	51228
	78	26			61,8	0,53	51308		240	80	397	15,5	51328 M
	90	36			112	1,10	51408	150	190	31	111	2,20	51130 F
45	65	14			24,2	0,14	51109		215	50	238	6,10	51230 M
	73	20			39,0	0,30	51209	160	200	31	112	2,35	51132 F
	85	28			76,1	0,66	51309		225	51	242	6,55	51232 M
	100	39			130	1,40	51409	170	240	34	133	3,30	51134 F
50	70	14			25,5	0,16	51110		240	55	286	8,15	51234 M
	78	22			49,4	0,37	51210	180	225	34	135	3,50	51136 F
	95	31			88,4	0,94	51310		250	56	296	8,60	51236 M
	110	43			159	2,00	51410	190	240	37	172	4,05	51138 F
55	78	16			30,7	0,23	51111		270	62	332	12,0	51238 M
	90	25			61,8	0,59	51211	200	250	37	168	4,25	51140 F
	105	35			104	1,30	51311		280	62	338	12,0	51240 M
	120	48			178	2,55	51411	220	270	37	178	4,60	51144 F
60	85	17			35,8	0,20	51112		300	63	351	13,0	51244 M
	95	26			62,4	0,65	51212	240	300	45	234	7,55	51148 F
	110	35			101	1,35	51312		340	78	462	23,0	51248 M
65	90	18			37,1	0,33	51113	260	320	45	238	8,10	51152 F
	100	27			63,7	0,78	51213		360	79	475	25,0	51252 M
	115	36			106	1,50	51313	280	350	53	319	12,0	51156 F
70	95	18			37,7	0,35	51114	300	380	62	364	17,5	51160 F



**Thrust ball bearings
single direction
with sphered housing washer
d 12–110 mm**

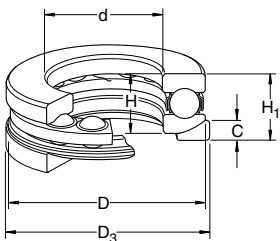

Dimensions						Basic load rating dynamic C	Masses Bearing	Seating washer	Designations	
d	D	D ₃	H	H ₁	C				Bearing	Seating washer
mm						kN	kg	–		
12	28	30	11,4	13	3,5	13,3	0,033	0,012	53201	U 201
15	32	35	13,3	15	4	16,5	0,049	0,014	53202	U 202
17	35	38	13,2	15	4	17,2	0,056	0,015	53203	U 203
20	40	42	14,7	17	5	22,5	0,082	0,020	53204	U 204
25	47	50	16,7	19	5,5	27,6	0,12	0,032	53205	U 205
30	52	55	17,8	20	5,5	25,5	0,14	0,038	53206	U 206
	60	62	22,6	25	7	37,7	0,27	0,056	53306	U 306
35	62	65	19,9	22	7	35,1	0,22	0,057	53207	U 207
	68	72	25,6	28	7,5	49,4	0,38	0,084	53307	U 307
40	68	72	20,3	23	7	46,8	0,28	0,070	53208	U 208
	78	82	28,5	31	8,5	61,8	0,55	0,12	53308	U 308
45	73	78	21,3	24	7,5	39	0,30	0,087	53209	U 209
	85	90	30,1	33	10	76,1	0,66	0,17	53309	U 309
50	78	82	23,5	26	7,5	49,4	0,37	0,10	53210	U 210
	95	100	34,4	37	11	88,4	0,97	0,23	53310	U 310
55	90	95	27,3	30	9	61,8	0,60	0,15	53211	U 211
	105	110	39,3	42	11,5	104	1,40	0,28	53311	U 311
60	95	100	28	31	9	62,4	0,66	0,16	53212	U 212
	110	115	38,3	42	11,5	101	1,40	0,31	53312	U 312
65	100	105	28,7	32	9	63,7	0,73	0,18	53213	U 213
	115	120	39,4	43	12,5	106	1,55	0,34	53313	U 313
70	105	110	28,8	32	9	65	0,78	0,19	53214	U 214
	125	130	44,2	48	13	135	2,10	0,41	53314	U 314
75	110	115	28,3	32	9,5	67,6	0,81	0,21	53215	U 215
	135	140	48,1	52	15	163	2,65	0,55	53315	U 315
80	115	120	29,5	33	10	76,1	0,90	0,22	53216	U 216
	140	145	47,6	52	15	159	2,75	0,57	53316	U 316
85	125	130	33,1	37	11	97,5	1,20	0,29	53217	U 217
	150	155	53,1	58	17,5	190	3,55	0,81	53317	U 317
90	135	140	38,5	42	13,5	119	1,70	0,42	53218	U 218
	155	160	54,6	59	18	195	3,85	0,84	53318	U 318
100	150	155	40,9	45	14	124	2,20	0,50	53220	U 220
	170	175	59,2	64	18	229	5,00	0,95	53320	U 320
110	160	165	40,2	45	14	130	2,35	0,56	53222	U 222
	190	195	67,2	72	20,5	276	7,80	1,30	53322 M	U 322

**Thrust ball bearings
double direction
d 10–150 mm**

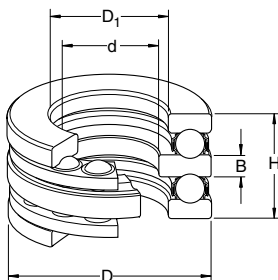

Dimensions					Basic load rating dynamic C	Mass	Designation
d	D	D ₁	B	H			
mm					kN	kg	–
10	32	17	5	22	16,5	0,081	52202
15	40	22	6	26	22,5	0,15	52204
20	47	27	7	28	27,6	0,22	52205
	52	27	8	34	34,5	0,33	52305
25	52	32	7	29	25,5	0,25	52206
	60	32	9	38	37,7	0,47	52306
30	62	37	8	34	35,1	0,41	52207
	68	42	9	36	46,8	0,55	52208
	68	37	10	44	49,4	0,68	52307
	78	42	12	49	61,8	1,05	52308
	90	42	15	65	112	2,05	52408
35	73	47	9	37	39	0,60	52209
	85	47	12	52	76,1	1,25	52309
	100	47	17	72	130	2,70	52409
40	78	52	9	39	49,4	0,71	52210
	95	52	14	58	88,4	1,75	52310
45	90	57	10	45	61,8	1,10	52211
	105	57	15	64	104	2,40	52311
	120	57	20	87	178	4,70	52411
50	95	62	10	46	62,4	1,20	52212
	110	62	15	64	101	2,55	52312
55	100	67	10	47	63,7	1,35	52213
	115	67	15	65	106	2,75	52313
	125	72	16	72	135	3,65	52314
60	110	77	10	47	67,6	1,55	52215
	135	77	18	79	163	4,80	52315
65	115	82	10	48	76,1	1,70	52216
	140	82	18	79	159	4,94	52316
70	125	88	12	55	97,5	2,40	52217
75	135	93	14	62	119	3,20	52218
85	150	103	15	67	124	4,20	52220
100	170	123	15	68	140	5,25	52224
110	190	133	18	80	186	8,00	52226
120	200	143	18	81	190	8,65	52228
130	215	153	20	89	238	11,5	52230 M
150	240	163	21	97	286	15,0	52234 M



Cylindrical roller thrust bearings

Cylindrical roller thrust bearings have a very simple design. They consist of two flat bearing washers with a cylindrical roller and cage thrust assembly between them. They can accommodate axial loads acting in one direction and provide for compact bearing arrangements which are insensitive to shock loads and can support very heavy loads. The bearings are separable and all components can be mounted separately.

SKF cylindrical roller thrust bearings have rollers which have only very small diameter deviations within one set and the rollers have a modified profile. As a result there is an even distribution of load within the bearing and damaging edge stresses are avoided.

Range

The SKF cylindrical roller thrust bearings listed in the table constitute the popular range. Other sizes and designs can also be supplied. Further information will be supplied on request.

Dimensions

The boundary dimensions of the bearings listed in the table are in accordance with ISO 104-1979.

Tolerances

SKF cylindrical roller thrust bearings are produced to Normal tolerances as standard. The tolerances conform to ISO 199-1979.

Cages

The SKF cylindrical roller thrust bearings included in the standard range are fitted with an injection moulded glass fibre reinforced polyamide 6,6 cage (suffix TN). Bearings with polyamide 6,6 cages can normally be used at temperatures up to +120 °C. For further information see page 30.

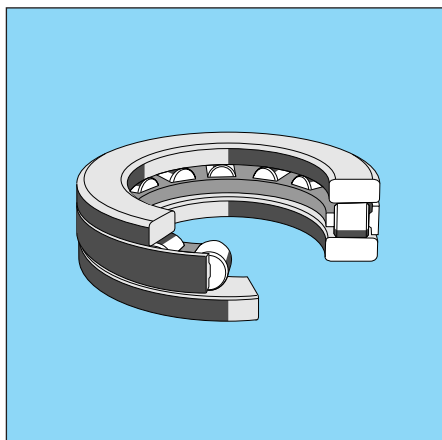

Cylindrical roller thrust bearings
d 15–100 mm

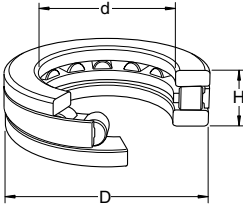

Dimensions			Basic load rating dynamic C	Mass	Designation
d	D	H			
mm			kN	kg	–
15	28	9	11,2	0,024	81102 TN
17	30	9	12,2	0,027	81103 TN
20	35	10	18,6	0,037	81104 TN
25	42	11	25	0,053	81105 TN
35	52	12	29	0,073	81107 TN
40	60	13	42,5	0,11	81108 TN
45	65	14	40,5	0,13	81109 TN
	73	20	86,5	0,30	81209 TN
50	70	14	47,5	0,14	81110 TN
	78	22	91,5	0,36	81210 TN
55	78	16	69,5	0,22	81111 TN
	90	25	122	0,57	81211 TN
60	85	17	80	0,27	81112 TN
	95	26	137	0,64	81212 TN
65	100	27	140	0,72	81213 TN
70	105	27	146	0,77	81214 TN
90	120	22	104	0,64	81118 TN
	135	35	232	1,75	81218 TN
100	135	25	146	1,00	81120 TN

Needle roller thrust bearings

Needle roller thrust bearings provide stiff bearing arrangements which are insensitive to shocks and can carry heavy loads. Bearing arrangements requiring no more space than a conventional thrust washer can be achieved if components of the machine can be used as raceways for the needle roller and cage thrust assembly.

For applications where this is not possible SKF offers various raceway washers. SKF needle roller thrust bearings consist of a form-stable cage which provides reliable guidance for the rollers. The needle rollers in an assembly have very small diameter deviations and a modified contact profile. This produces an even load distribution within the bearing and damaging edge stresses are avoided.

Range

Because of the variety of possible combinations of needle roller and cage thrust assemblies with the raceway and the thrust washers, the components must be ordered separately. The AS thrust washers are made of spring steel and are hardened and polished. The LS raceway washers are made of carbon chromium steel and are hardened. The raceways are ground and the bore and outside diameters are turned. Details of other assemblies and washers and their availability will be sent on request.

Dimensions

The dimensions of the needle roller and cage thrust assemblies listed in the table are in accordance with ISO 3031. The bore and outside diameters of the raceway washers correspond to Diameter Series 1, ISO 104-1979 (thrust bearings). The dimensions of the AS thrust washers are according to DIN 5405 Part 3.

Tolerances

SKF needle roller thrust bearings have a bore tolerance to E10 and an outside diameter tolerance c12. The bore diameter tolerance for the AS thrust washers and LS raceway washers is E12 and the outside diameters are machined to tolerance e12. The tolerances of the WS shaft washers and GS housing washers are in accordance with ISO 199-1979, Normal tolerances.

Cages

Depending on size, SKF needle roller and cage thrust assemblies incorporate injection moulded cages of glass fibre reinforced polyamide 6,6 (suffix TN) or pressed steel cages. The polyamide cages can normally be used at temperatures up to +120 °C. For further information, see page 30.

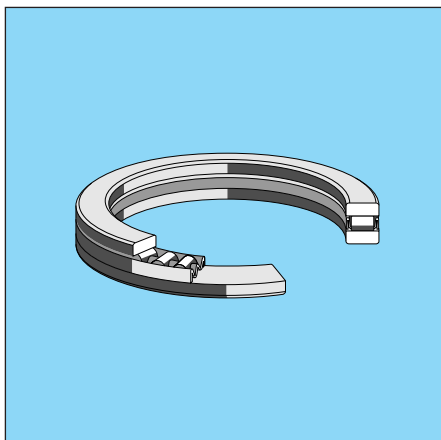

Needle roller thrust bearings

d 8–100 mm

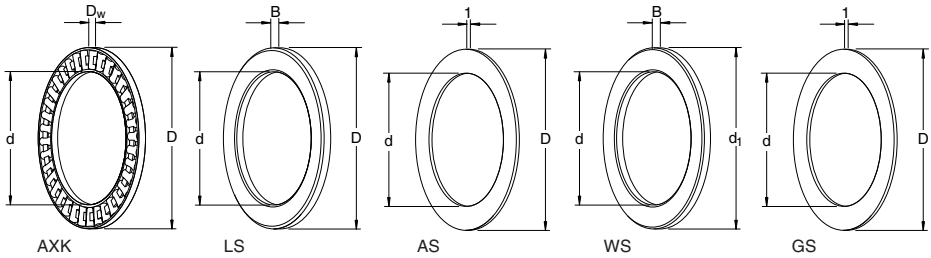

Dimensions						Basic load rating dynamic C	Mass Needle roller and cage thrust assembly	Designations Needle roller and cage thrust assembly	Raceway washer	Thrust washer	Shaft washer	Housing washer
d	d ₁	D	D ₁	D _w	B							
mm						kN	g	–				
8	–	21	–	2	2,75	7,2	2	AXK 0821 TN	LS 0821	AS 0821	–	–
10	–	24	–	2	2,75	8,5	3	AXK 1024	LS 1024	AS 1024	–	–
12	–	26	–	2	2,75	9,15	3	AXK 1226	LS 1226	AS 1226	–	–
20	35	35	21	2	2,75	12	5	AXK 2035	LS 2035	AS 2035	WS 81104	GS 81104
25	42	42	26	2	3	13,4	7	AXK 2542	LS 2542	AS 2542	WS 81105	GS 81105
30	47	47	32	2	3	15	8	AXK 3047	LS 3047	AS 3047	WS 81106	GS 81106
40	60	60	42	3	3,5	25	16	AXK 4060	LS 4060	AS 4060	WS 81108	GS 81108
45	65	65	47	3	4	27	18	AXK 4565	–	AS 4565	WS 81109	GS 81109
50	70	70	52	3	4	28,5	20	AXK 5070	LS 5070	AS 5070	WS 81110	GS 81110
55	78	78	57	3	5	34,5	28	AXK 5578	–	AS 5578	WS 81111	GS 81111
60	85	85	62	3	4,75	37,5	33	AXK 6085	–	AS 6085	WS 81112	GS 81112
65	90	90	67	3	5,25	39	35	AXK 6590	LS 6590	–	WS 81113	GS 81113
70	95	95	72	4	5,25	49	60	AXK 7095	–	AS 7095	WS 81114	GS 81114
75	100	100	77	4	5,75	50	61	AXK 75100	–	–	WS 81115	GS 81115
80	–	105	–	4	–	51	63	AXK 80105	–	–	–	–
85	–	110	–	4	–	52	67	AXK 85110	–	AS 85110	–	–
90	120	120	92	4	6,5	65,5	86	AXK 90120	LS 90120	AS 90120	WS 81118	GS 81118
100	135	135	102	4	7	76,5	105	AXK 100135	–	AS 100135	WS 81120	GS 81120



Spherical roller thrust bearings

Spherical roller thrust bearings have raceways which are arranged at an angle to the bearing axis. In contrast to other thrust bearings, therefore, they are able to accommodate radial loads in addition to axial loads. The bearings are also insensitive to shaft bending or errors of alignment between shaft and housing. The bearings are separable. The shaft washer with roller and cage assembly can be mounted independently of the housing washer.

SKF spherical roller thrust bearings contain a large number of asymmetrical rollers and have optimised roller/racway conformity. Bearings of the E design represent the latest generation of SKF spherical roller thrust bearings with refined internal geometry which makes them able to carry much heavier loads and have less friction than the other bearings. The benefits resulting from this include

- much longer life or greater reliability,
- low-friction operation and lower operating temperatures,
- compact bearing arrangements and the ability to operate at higher speeds.

An additional benefit is that these E-design bearings need no running in, another point in favour of SKF spherical roller thrust bearings.

Range

Depending on bearing size and series, SKF spherical roller thrust bearings are produced in one of two designs. Bearings of the E design have a pressed steel window-type cage which forms a unit with the rollers and the shaft washer. These bearings are also suitable for grease lubrication. The other bearings have a machined brass cage which is guided and retained by a sleeve fixed in the bore of the shaft washer.

Details of larger SKF spherical roller thrust bearings and their availability will be supplied on request.

Dimensions

The boundary dimensions of the spherical roller thrust bearings listed in the table are in accordance with ISO 104-1979.

Tolerances

SKF spherical roller thrust bearings are produced with Normal tolerances as standard. The tolerances conform to ISO 199-1979.

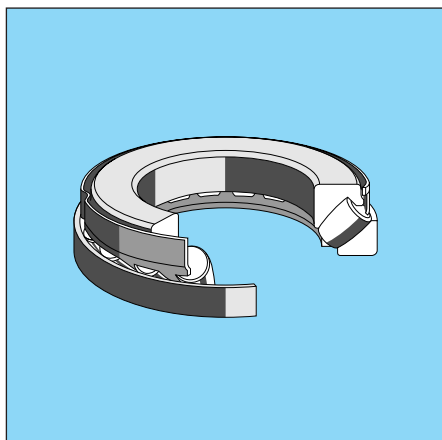

Spherical roller thrust bearings

d 60–300 mm

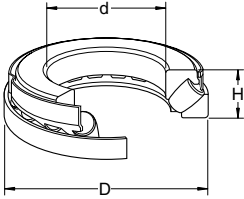

Dimensions			Basic load rating dynamic C	Mass	Designation
d	D	H			
mm			kN	kg	–
60	130	42	345	2,60	29412 E
65	140	45	397	3,20	29413 E
70	150	48	449	3,90	29414 E
75	160	51	518	4,70	29415 E
80	170	54	575	5,60	29416 E
85	150	39	334	2,75	29317 E
	180	58	633	6,75	29417 E
90	155	39	345	2,85	29318 E
	190	60	702	7,75	29418 E
100	170	42	408	3,65	29320 E
	210	67	863	10,5	29420 E
110	190	48	535	5,30	29322 E
	230	73	1 010	13,5	29422 E
120	210	54	656	7,35	29324 E
	250	78	1 170	17,5	29424 E
130	225	58	753	9,00	29326 E
	270	85	1 380	22,0	29426 E
140	240	60	845	10,5	29328 E
	280	85	1 400	23,0	29428 E
150	215	39	345	4,55	29230
	250	60	863	11,0	29330 E
	300	90	1 610	28,0	29430 E
160	270	67	1 010	14,5	29332 E
	320	95	1 790	33,5	29432 E
170	280	67	1 050	15,0	29334 E
	340	103	2 020	44,5	29434 E
180	250	42	420	6,25	29236
	300	73	1 240	19,5	29336 E
	360	109	2 250	52,5	29436 E
190	320	78	1 400	23,5	29338 E
	380	115	2 480	60,5	29438 E
200	280	48	535	8,90	29240
	340	85	1 610	29,5	29340 E
	400	122	2 760	72,0	29440 E
220	300	48	546	10,0	29244
	360	85	1 730	33,5	29344 E
	420	122	2 880	75,0	29444 E

Dimensions			Basic load rating dynamic C	Mass	Designation
d	D	H			
mm			kN	kg	–
240	340	60	799	16,5	29248
	380	85	1 790	35,5	29348 E
	440	122	2 990	80,0	29448 E
260	360	60	817	18,5	29252
	420	95	2 220	49,0	29352 E
	480	132	3 510	105	29452 E
280	380	60	863	19,5	29256
	440	95	2 190	53,0	29356 E
	520	145	4 310	135	29456 E
300	480	109	2 670	75,0	29360 E



Combined needle roller bearings

Combined needle roller bearings are radial needle roller bearings with integral thrust ball bearings or roller thrust bearings. They can accommodate radial as well as axial loads and enable support or locating bearing arrangements to be designed which require a minimum of radial space. Their use is advantageous, for example, where simple thrust washers are inadequate for the axial loads and there is no space for other bearing types. All SKF combined needle roller bearings have an annular groove and one lubrication hole in the needle roller bearing outer ring.

Range

Needle roller/angular contact ball bearings

These SKF combined bearings are available in two designs. Bearings of series NKIA 59 with one-piece inner ring can take up axial loads in one direction. Bearings of series NKIB 59 with two-part inner ring, on the other hand, can be used to locate a shaft in both directions – with an axial play of 0,08 to 0,25 mm. The axial load on these bearings

should not exceed 25 % of the simultaneously acting radial load.

Needle roller/thrust ball bearings

These SKF bearings, series NKX and NKX .. Z, are a combination of a needle roller bearing and a thrust ball bearing of series 511. They can carry heavy radial and axial loads.

Bearings of series NKX are separable. The needle roller bearing with integral housing washer, the ball and cage thrust assembly, and the shaft washer can be mounted separately. Bearings of series NKX .. Z have a retaining cover which is attached to the housing washer and extends over the shaft washer, forming a gap-type seal with the shaft washer. These non-separable bearings are particularly suitable for grease lubrication.

In addition to the bearings described above the SKF popular range also comprises

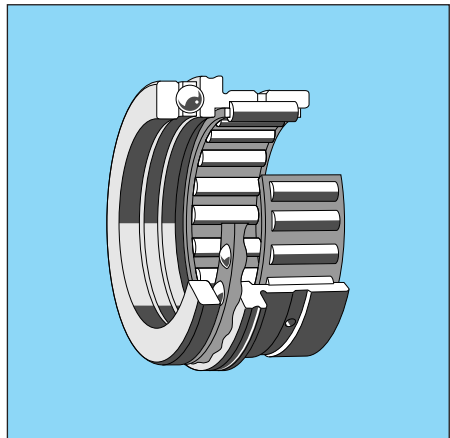
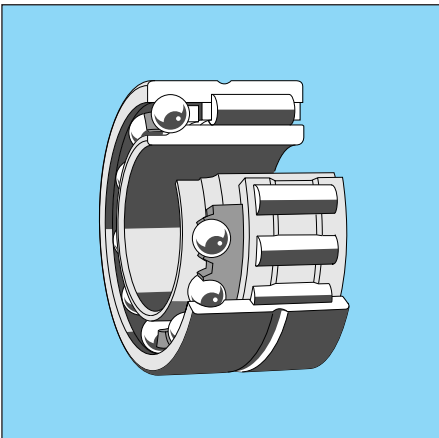

- needle roller/full complement thrust ball bearings, and
- needle roller/cylindrical roller thrust bearings,

which are not shown in the tables. Details will be sent on request.

Dimensions

The boundary dimensions of the combined needle roller bearings listed in the tables are in accordance with the following standards: needle roller/angular contact ball bearings: DIN 5429 Part 2; needle roller/thrust ball bearings DIN 5429 Part 1.

Tolerances

SKF combined needle roller bearings are manufactured as standard with Normal tolerances to ISO 492:1994 and ISO 199-1979, except for the width of the two-part inner ring of bearings of series NKIB which has a uniform tolerance of $0/-0,3$ mm.

The diameter F_w for all bearings without inner ring corresponds to tolerance F6 before the bearings are mounted.

Internal clearance

SKF needle roller/angular contact ball bearings have Normal radial internal clearance as specified in ISO 5373:1991. The components of the bearings must remain together as supplied.

Cages

SKF needle roller/angular contact ball bearings: the needle roller bearing is fitted with a steel or pressed steel cage and the angular contact ball bearing has a snap-type cage of polyamide 6,6.

SKF needle roller/thrust ball bearings have cages of steel or pressed steel. The needle roller bearing of the smaller sizes has a polyamide 6,6 cage (identified by suffix TN).

Bearings with polyamide 6,6 cages can normally be used at temperatures up to $+120$ °C. For further information see page 30.

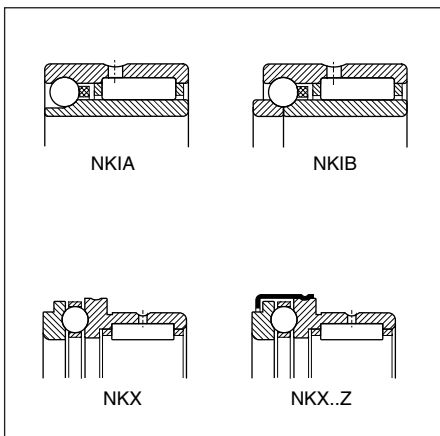

Needle roller/angular contact ball bearing
d 12–70 mm

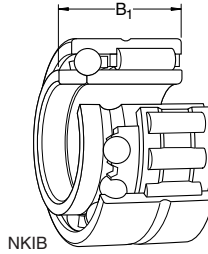
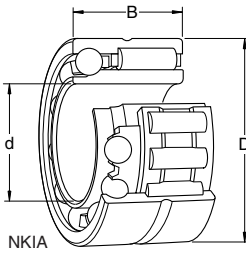

Dimensions				Basic load ratings		Masses		Designations	
d	D	B	B ₁	dynamic radial C	axial	NKIA	NKIB	Single direction	Double direction
mm				kN		kg		–	
12	24	16	17,5	8,25	2,07	0,04	0,043	NKIA 5901	NKIB 5901
15	28	18	20	11,4	2,27	0,05	0,052	NKIA 5902	NKIB 5902
17	30	18	20	11,7	2,24	0,056	0,058	NKIA 5903	NKIB 5903
20	37	23	25	21,6	3,79	0,10	0,11	NKIA 5904	NKIB 5904
22	39	23	25	23,3	4,14	0,12	0,12	NKIA 59/22	NKIB 59/22
25	42	23	25	24,2	4,24	0,13	0,13	NKIA 5905	NKIB 5905
30	47	23	25	25,5	4,54	0,15	0,15	NKIA 5906	NKIB 5906
35	55	27	30	31,9	5,83	0,24	0,25	NKIA 5907	NKIB 5907
40	62	30	34	42,9	7,17	0,32	0,32	NKIA 5908	NKIB 5908
45	68	30	34	45,7	7,47	0,37	0,38	NKIA 5909	NKIB 5909
50	72	30	34	47,3	7,74	0,38	0,39	NKIA 5910	NKIB 5910
55	80	34	38	57,2	9,27	0,55	0,56	NKIA 5911	NKIB 5911
60	85	34	38	59,4	9,58	0,59	0,60	NKIA 5912	NKIB 5912
65	90	34	38	60,5	9,96	0,64	0,64	NKIA 5913	NKIB 5913
70	100	40	45	84,2	13,2	0,98	0,99	NKIA 5914	NKIB 5914

Needle roller/thrust ball bearings

F_w 10–70 mm

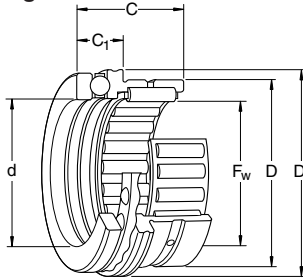

Dimensions					Basic load ratings		Masses		Designations	
F_w , d	D	D ₁	C	C ₁	dynamic radial C	axial C	NKX	NKX .. Z	Bearing without cover	with cover
mm					kN		kg		–	
10	19	25,2	23	9	5,94	9,95	0,034	0,038	NKX 10 TN	NKX 10 ZTN
12	21	27,2	23	9	6,16	10,4	0,038	0,040	NKX 12	NKX 12 Z
15	24	29,2	23	9	11,2	10,6	0,044	0,047	NKX 15	NKX 15 Z
17	26	31,1	25	9	12,3	10,8	0,053	0,055	NKX 17	NKX 17 Z
20	30	36,2	30	10	16,8	14,3	0,083	0,090	NKX 20	NKX 20 Z
25	37	43,2	30	11	19,0	19,5	0,13	0,13	NKX 25	NKX 25 Z
30	42	48,2	30	11	22,9	20,3	0,14	0,15	NKX 30	NKX 30 Z
35	47	53,2	30	12	24,6	20,3	0,16	0,17	NKX 35	NKX 35 Z
40	52	61,2	32	13	26,4	27,0	0,20	0,21	NKX 40	NKX 40 Z
45	58	66,5	32	14	28,1	28,1	0,25	0,27	NKX 45	NKX 45 Z
50	62	71,5	35	14	38,0	28,6	0,28	0,30	NKX 50	NKX 50 Z
60	72	86,5	40	17	41,8	41,6	0,36	0,38	NKX 60	NKX 60 Z
70	85	96,5	40	18	44,6	43,6	0,50	0,52	NKX 70	NKX 70 Z

Precision bearings

Precision single row angular contact ball bearings

Precision single row angular contact ball bearings are mainly used in machine tools, i.e. applications where high or very high demands regarding running accuracy and speed capability exist.

SKF precision single row angular contact ball bearings are non-separable and their internal design represents the latest state of the art for machine tool spindle bearings. They have small contact angles and a particularly lightweight resin cage with many balls. Only one bearing ring has a low shoulder. The derived benefits include

- very high load carrying capacity and stiffness,
- very high speed capability,
- low friction and cool running.

Range

SKF precision single row angular contact ball bearings are available in three dimension series – series 719, 70 and 72 – with a contact angle of 15° (suffix CD) or 25° (suffix ACD). Bearings with the larger angle are mainly used where high axial stiffness and high axial load carrying capacity are required. Availability should be checked before ordering.

SKF precision angular contact ball bearings are produced as “universal” bearings for paired mounting as standard. These bearings are factory matched so that after mounting in a face-to-face or back-to-back arrangement, the bearings will have a light preload (suffix GA). When ordering, it is necessary to state the number of individual bearings required and not the number of bearing pairs.

Dimensions

The boundary dimensions of the precision single row angular contact ball bearings listed in the table are in accordance with ISO 15-1981.

Tolerances

SKF precision single row angular contact ball bearings are produced as standard to tolerance class P4A specifications. These correspond to ISO 492:1994, class 4, but the running accuracy is better than class 4.

Cages

SKF precision single row angular contact ball bearings are fitted with a machined fabric reinforced phenolic resin cage which is centred in the outer ring.

Supplementary designations

The suffixes frequently used for SKF precision single row angular contact ball bearings are explained in the following.

ACD 25° contact angle

CD 15° contact angle

CDGA CD + GA

GA “Universal” bearing for pairing in random order; the bearings will have a light preload when mounted

HC Hybrid bearing with steel rings and ceramic balls

P4A Dimensional accuracy to ISO tolerance class 4; running accuracy better than class 4

Precision angular contact ball bearings
single row
d 8–100 mm

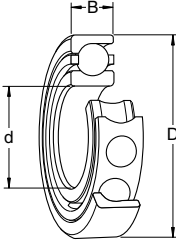

Dimensions			Basic load rating dynamic C	Mass	Designation
d	D	B			
mm			kN	kg	–
8	22	7	2,96	0,011	708 CDGA/P4A
9	24	7	3,25	0,014	709 CDGA/P4A
10	22	6	2,51	0,009	71900 CDGA/P4A
	26	8	4,1	0,018	7000 CDGA/P4A
	30	9	5,4	0,029	7200 CDGA/P4A
12	24	6	2,65	0,010	71901 CDGA/P4A
	28	8	4,49	0,020	7001 CDGA/P4A
	32	10	5,85	0,036	7201 CDGA/P4A
15	28	7	3,97	0,015	71902 CDGA/P4A
	32	9	5,2	0,028	7002 CDGA/P4A
	35	11	7,41	0,043	7202 CDGA/P4A
17	30	7	4,16	0,017	71903 CDGA/P4A
	35	10	6,76	0,037	7003 CDGA/P4A
	40	12	9,23	0,062	7203 CDGA/P4A
20	37	9	6,05	0,035	71904 CDGA/P4A
	42	12	8,71	0,065	7004 CDGA/P4A
	47	14	11,9	0,10	7204 CDGA/P4A
25	42	9	6,76	0,042	71905 CDGA/P4A
	47	12	9,56	0,075	7005 CDGA/P4A
	52	15	13,5	0,14	7205 CDGA/P4A
30	47	9	7,15	0,048	71906 CDGA/P4A
	55	13	14,3	0,11	7006 CDGA/P4A
	62	16	24,2	0,19	7206 CDGA/P4A
35	55	10	9,75	0,074	71907 CDGA/P4A
	62	14	15,6	0,15	7007 CDGA/P4A
	72	17	31,9	0,28	7207 CDGA/P4A
40	62	12	12,4	0,11	71908 CDGA/P4A
	68	15	16,8	0,19	7008 CDGA/P4A
	80	18	41	0,36	7208 CDGA/P4A
45	68	12	13	0,13	71909 CDGA/P4A
	75	16	28,6	0,23	7009 CDGA/P4A
	85	19	42,3	0,41	7209 CDGA/P4A
50	72	12	13,5	0,13	71910 CDGA/P4A
	80	16	29,6	0,25	7010 CDGA/P4A
	90	20	44,9	0,46	7210 CDGA/P4A
55	80	13	19,5	0,18	71911 CDGA/P4A
	90	18	39,7	0,37	7011 CDGA/P4A
	100	21	55,3	0,61	7211 CDGA/P4A
60	85	13	19,9	0,19	71912 CDGA/P4A
	95	18	40,3	0,40	7012 CDGA/P4A
	110	22	67,6	0,80	7212 CDGA/P4A

Dimensions			Basic load rating dynamic C	Mass	Designation
d	D	B			
mm			kN	kg	–
65	90	13	20,8	0,21	71913 CDGA/P4A
	100	18	41,6	0,42	7013 CDGA/P4A
	120	23	76,1	1,00	7213 CDGA/P4A
70	100	16	34,5	0,33	71914 CDGA/P4A
	110	20	52	0,59	7014 CDGA/P4A
	125	24	79,3	1,10	7214 CDGA/P4A
75	105	16	35,8	0,35	71915 CDGA/P4A
	115	20	52,7	0,62	7015 CDGA/P4A
	130	25	83,2	1,20	7215 CDGA/P4A
80	110	16	36,4	0,37	71916 CDGA/P4A
	125	22	65	0,85	7016 CDGA/P4A
	140	26	97,5	1,45	7216 CDGA/P4A
85	130	22	67,6	0,89	7017 CDGA/P4A
	150	28	99,5	1,80	7217 CDGA/P4A
90	140	24	79,3	1,15	7018 CDGA/P4A
	160	30	127	2,25	7218 CDGA/P4A
100	150	24	83,2	1,25	7020 CDGA/P4A
	180	34	156	3,25	7220 CDGA/P4A



Precision double row cylindrical roller bearings

Precision double row cylindrical roller bearings are of separable design with low sectional height. This enables large shaft or spindle diameters to be used. The bearing properties are such that the bearings are eminently suitable for heavily loaded machine tool spindle applications.

The benefits of SKF precision double row cylindrical roller bearings include

- very high radial load carrying capacity and stiffness,
- very high dimensional and running accuracy, and
- the ability to operate at high speeds.

Another advantage is that all larger bearings have an annular groove and three lubrication holes in the outer ring to facilitate efficient lubrication.

Range

SKF precision double row cylindrical roller bearings are available in two designs: the NN and the NNU. The rollers of bearings of the NN design are guided between integral flanges on the inner ring, and those of the NNU design between integral flanges in the outer ring.

The bearings are available both with cylindrical as well as with tapered bore (taper 1:12), bearings of series NN 30 usually have a tapered bore. When using bearings with tapered bore it is possible to set a given radial internal clearance or preload very accurately.

Dimensions

The boundary dimensions of the precision double row cylindrical roller bearings listed in the tables are in accordance with ISO 15-1981.

Tolerances

SKF precision double row cylindrical roller bearings are produced as standard with tolerances to class SP specifications which were established especially for machine tool bearings.

Internal clearance

SKF precision double row cylindrical roller bearings are produced with C1 radial internal clearance to ISO 5373:1991 as standard. This is not indicated in the bearing designation. The bearing rings of one bearing cannot be interchanged with those of another bearing.

Cages

Depending on bearing series and size, SKF precision cylindrical roller bearings incorporate

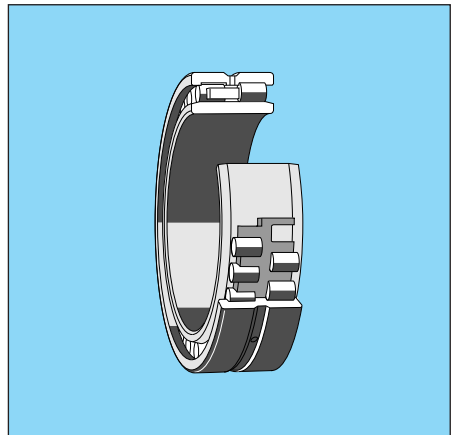
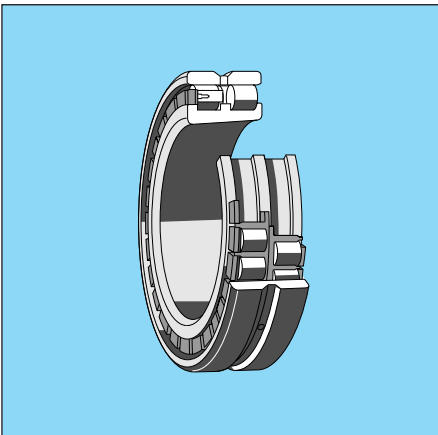

- a double pronged machined brass cage,
or
- two roller guided polyamide 6,6 cages.

Bearings with polyamide 6,6 cages can normally be used at temperatures up to +120 °C. For further information see page 30.

Supplementary designations

The suffixes which are frequently used with SKF precision double row cylindrical roller bearings are explained in the following.

B	Changed internal design
BK	B + K
K	Tapered bore, taper 1:12
KTN	K + TN
KTN9	K + TN9
SP	Dimensional accuracy corresponding approximately to ISO tolerance class 5, running accuracy approximately to ISO class 4 specifications
SPW33	SP + W33
TN	Injection moulded cage of polyamide 6,6
TN9	Injection moulded cage of glass fibre reinforced polyamide 6,6
W33	Annular groove and three lubrication holes in outer ring

Precision cylindrical roller bearings

double row

d 25–170 mm

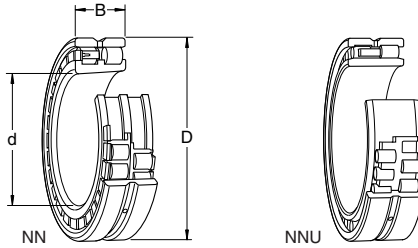

Dimensions			Basic load rating dynamic C	Mass	Designations Bearing with cylindrical bore	tapered bore
d	D	B				
mm			kN	kg	–	
25	47	16	26	0,12	–	NN 3005 K/SP
30	55	19	30,8	0,19	NN 3006/SP	–
35	62	20	39,1	0,25	NN 3007/SP	NN 3007 K/SP
40	68	21	42,9	0,30	NN 3008 TN/SP	NN 3008 KTN/SP
45	75	23	50,1	0,38	NN 3009 TN/SP	NN 3009 KTN/SP
50	80	23	52,8	0,42	NN 3010 TN/SPW33	NN 3010 KTN/SPW33
55	90	26	69,3	0,62	NN 3011 TN/SPW33	NN 3011 KTN/SPW33
60	95	26	73,7	0,66	NN 3012 TN/SPW33	NN 3012 KTN/SPW33
65	100	26	76,5	0,71	NN 3013 TN/SPW33	NN 3013 KTN/SPW33
70	110	30	96,8	1,00	NN 3014 TN/SPW33	NN 3014 KTN/SPW33
75	115	30	96,8	1,10	NN 3015 TN/SPW33	NN 3015 KTN/SPW33
80	125	34	119	1,50	NN 3016 TN/SPW33	NN 3016 KTN/SPW33
85	130	34	125	1,60	NN 3017 TN9/SPW33	NN 3017 KTN9/SPW33
90	140	37	138	2,00	NN 3018 TN9/SPW33	NN 3018 KTN9/SPW33
95	145	37	142	2,10	–	NN 3019 KTN9/SPW33
100	140	40	128	1,90	NNU 4920 B/SPW33	NNU 4920 BK/SPW33
	150	37	151	2,20	NN 3020 TN9/SPW33	NN 3020 KTN9/SPW33
105	145	40	130	2,00	NNU 4921 B/SPW33	NNU 4921 BK/SPW33
	160	31	190	2,80	–	NN 3021 KTN9/SPW33
110	150	40	132	2,05	NNU 4922 B/SPW33	NNU 4922 BK/SPW33
	170	45	220	3,55	NN 3022 TN9/SPW33	NN 3022 KTN9/SPW33
120	165	45	176	2,80	NNU 4924 B/SPW33	NNU 4924 BK/SPW33
	180	46	229	3,85	–	NN 3024 KTN9/SPW33
130	180	50	187	3,85	NNU 4926 B/SPW33	NNU 4926 BK/SPW33
	200	52	286	5,75	–	NN 3026 KTN9/SPW33
140	190	50	190	4,10	NNU 4928 B/SPW33	NNU 4928 BK/SPW33
	210	53	297	6,20	–	NN 3028 K/SPW33
150	210	60	330	6,25	NNU 4930 B/SPW33	NNU 4930 BK/SPW33
	225	56	330	7,50	–	NN 3030 K/SPW33
160	220	60	330	6,60	NNU 4932 B/SPW33	NNU 4932 BK/SPW33
	240	60	369	9,10	–	NN 3032 K/SPW33
170	230	60	336	6,95	NNU 4934 B/SPW33	NNU 4934 BK/SPW33
	260	67	457	12,5	–	NN 3034 K/SPW33

Precision cylindrical roller bearings
double row
d 180–260 mm

Dimensions			Basic load rating dynamic C	Mass	Designations Bearing with cylindrical bore	tapered bore
d	D	B				
mm			kN	kg	–	
180	250	69	402	10,5	NNU 4936 B/SPW33	NNU 4936 BK/SPW33
	280	74	561	16,5	–	NN 3036 K/SPW33
190	260	69	402	11,0	NNU 4938 B/SPW33	NNU 4938 BK/SPW33
	290	75	594	17,0	–	NN 3038 K/SPW33
200	280	80	484	15,0	NNU 4940 B/SPW33	–
	310	82	644	22,0	–	NN 3040 K/SPW33
220	300	80	512	16,5	NNU 4944 B/SPW33	NNU 4944 BK/SPW33
	340	90	809	28,5	–	NN 3044 K/SPW33
240	320	80	528	17,5	NNU 4948 B/SPW33	NNU 4948 BK/SPW33
	360	92	842	32,0	–	NN 3048 K/SPW33
260	400	104	1 020	46,0	–	NN 3052 K/SPW33

Precision double direction angular contact thrust ball bearings

These precision double direction angular contact thrust ball bearings were developed by SKF specifically for machine tool work spindles. The bearings can locate a spindle axially in both directions and are intended for use together with SKF precision double row cylindrical roller bearings of series NN 30 K. The bearings are separable. The various parts of the bearing can be mounted separately so that mounting is easy.

SKF precision angular contact thrust ball bearings have a contact angle of 60°. This gives high axial load carrying capacity and particularly high axial stiffness. The bearings are capable of operating at relatively high speeds. For even higher speeds, bearings of similar design with a contact angle of 40° are available.

Range

Two series of SKF precision double direction angular contact thrust ball bearings belong to the SKF popular range – series 2344(00) and series 2347(00).

The bearings of series 2344(00) are designed for mounting at the small diameter side of the tapered cylindrical roller bearing seating on the spindle, whilst bearings of series 2347(00) should be mounted at the large diameter side.

Dimensions

The bore and outside diameters of the double direction angular contact thrust ball bearings listed in the table follow those of Diameter Series 0 for radial bearings, ISO 15-1981.

Tolerances

SKF precision double direction angular contact thrust ball bearings are produced as standard to tolerance class SP specifications which were especially established for machine tool bearings.

Preload

The length of the spacer sleeve between the two shaft washers is so dimensioned that, after mounting, the bearings will have an appropriate preload.

Cages

Depending on bearing size, SKF precision double direction angular contact thrust ball bearings incorporate

- a machined brass cages, or
- an injection moulded glass fibre reinforced polyamide 6,6 cages.

Bearings with polyamide 6,6 cages can normally be used at temperatures up to +120 °C. For further information see page 30.

Supplementary designations

The suffixes which are frequently used with SKF precision double direction angular contact thrust ball bearings are explained in the following.

B	Changed internal design
BM1	B + M1
HC	Hybrid bearing with steel washers and ceramic balls
M1	Machined brass cage (two per bearing)
SP	Dimensional accuracy approximately to ISO tolerance class 5 and running accuracy approximately to ISO class 4 specifications
TN9	Injection moulded glass fibre reinforced polyamide 6,6 cage (two per bearing)

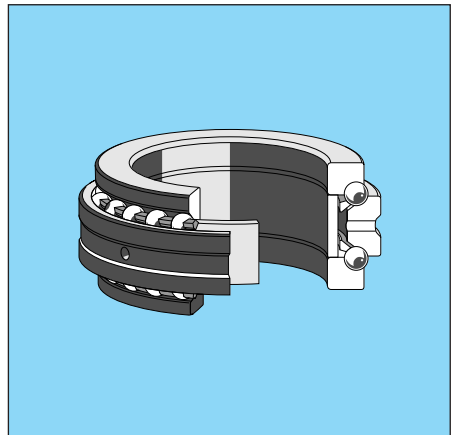

**Precision angular contact thrust ball bearings
double direction
d 35–140 mm**

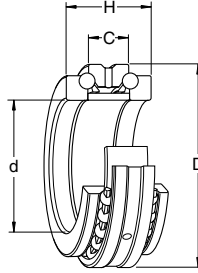

Dimensions				Basic load rating dynamic C	Mass	Designation
d	D	H	C			
mm				kN	kg	–
35	62	34	17	18,6	0,38	234407 BM1/SP
40	68	36	18	21,6	0,46	234408 BM1/SP
45	75	38	19	24,5	0,58	234409 BM1/SP
50	80	38	19	25,5	0,62	234410 BM1/SP
55	90	44	22	34	0,94	234411 BM1/SP
57	90	44	22	34	0,90	234711 BM1/SP
60	95	44	22	34,5	1,00	234412 TN9/SP
62	95	44	22	34,5	0,94	234712 TN9/SP
65	100	44	22	36	1,05	234413 TN9/SP
70	110	48	24	44	1,45	234414 TN9/SP
75	115	48	24	44	1,55	234415 BM1/SP
80	125	54	27	54	2,10	234416 TN9/SP
83	125	54	27	54	1,95	234716 TN9/SP
85	130	54	27	54	2,20	234417 TN9/SP
90	140	60	30	62	3,00	234418 TN9/SP
95	145	60	30	64	3,05	234419 BM1/SP
100	150	60	30	67	3,15	234420 TN9/SP
110	170	72	36	93	5,05	234422 BM1/SP
120	180	72	36	93	5,70	234424 TN9/SP
130	200	84	42	116	8,15	234426 TN9/SP
140	210	84	42	116	8,65	234428 BM1/SP

Track runner bearings

A track runner bearing is, as the name suggests, a bearing with an outer ring, generally reinforced, which is designed to run on a track. The track runner bearings shown in this catalogue are support rollers and cam followers. The support rollers are available, depending on design, with or without inner ring and are intended for mounting on shafts. The cam followers have a solid stud (pin) in place of an inner ring. The stud is threaded at one end for quick and easy attachment to appropriate machine components.

SKF support rollers and cam followers are available in a variety of designs, with or without seals, with cylindrical or sphered outside diameter, and with cage or a full complement of rollers. Their common feature is their robust quality. Because of the variety of designs, they enable “tailored” solutions to be achieved for very different operating and load conditions.

Range

The following products are included in the SKF popular range:

- support rollers without axial guidance, with and without inner ring, series STO and RSTO;
- sealed support rollers without axial guidance, with and without inner ring, series NA 22.2RS and RNA 22.2RS;
- support rollers with axial guidance, series NATR and NATV and series NUTR;
- cam followers, series KR and KRV, and series NUKR.

All SKF support rollers and cam followers except those of series NAST are supplied filled with a lithium base grease which has good rust inhibiting properties and an operating temperature range of -30 to $+110$ °C.

Tolerances

SKF support rollers and cam followers are produced to Normal bearing tolerances in accordance with ISO 492:1994. The exception is the tolerance of the diameter of the sphered outside surface – this is a uniform $0/-0,05$ mm for all sizes. The tolerance for the width B of support rollers of series NAST,

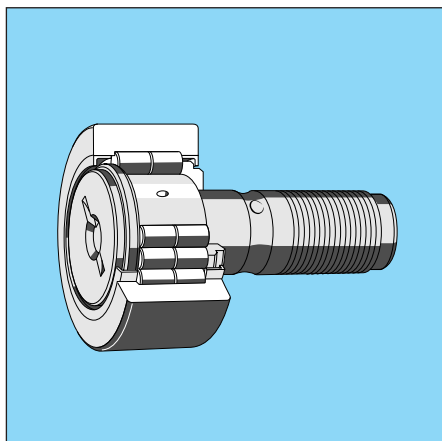
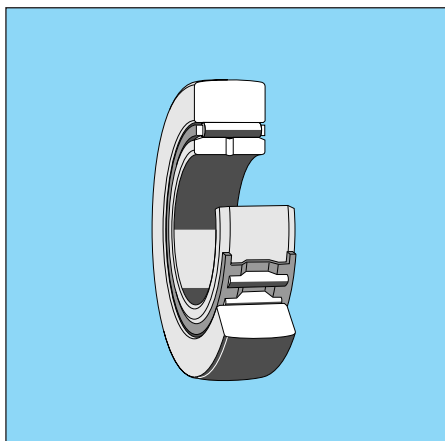

NATR, NATV and NUTR is also an exception – it corresponds to h12.

The internal diameter Fw of the roller set when the rollers are in contact with the outer ring raceway is to tolerance F6 for the support rollers without inner ring, series RSTO and RNA 22.2RS.

The diameter of the stud of the cam followers is to tolerance h7.

Cages

SKF support rollers and cam followers, unless they are of the full complement type, are fitted with a cage of steel or sheet steel, except for support rollers of series STO and RSTO having an outside diameter of up to and including 24 mm. These have a cage of glass fibre reinforced polyamide 6,6. Support rollers with polyamide cage can generally be used at operating temperatures up to +120 °C. For further information, see page 30.

Supplementary designations

The suffixes frequently used with SKF support rollers and cam followers are explained in the following.

PP	Polyurethane seal (rubbing seal) at both sides
PPX	PP + X
.2RS	Synthetic rubber seal (rubbing seal) with sheet steel reinforcement at both sides of bearing
.2RSX	2RS + X
TN	Injection moulded cage of glass fibre reinforced polyamide 6,6
X	Cylindrical outside surface
XTN	X + TN

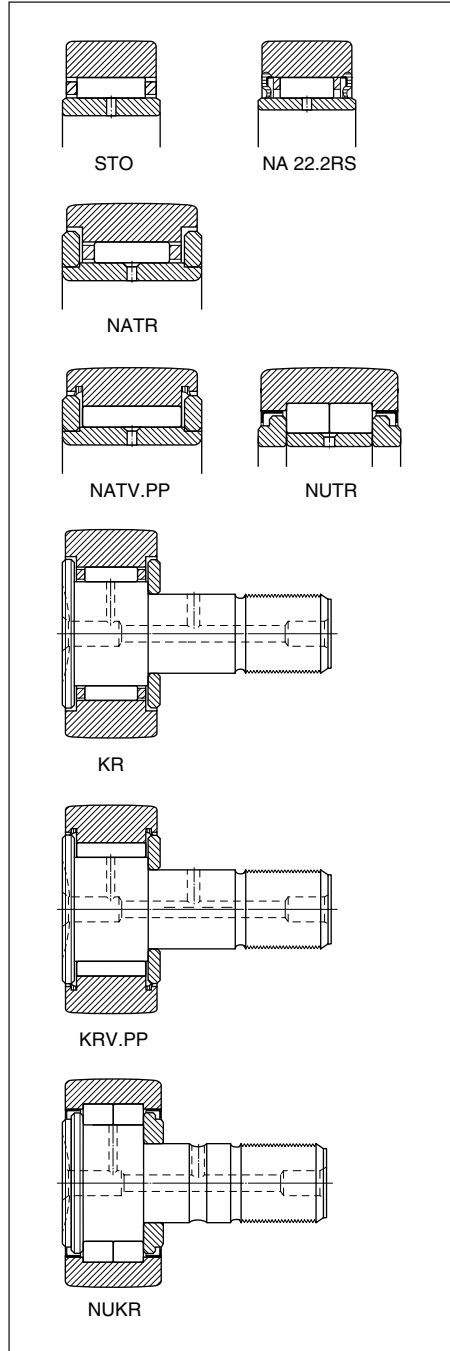

Support rollers without axial guidance

D 16–62 mm

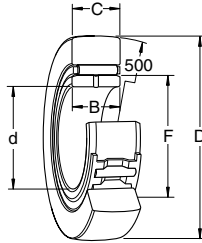

Dimensions					Basic load rating Support roller dynamic C	Masses		Designations	
D	C	B	d	F		RSTO	STO	Support roller without inner ring	with inner ring
mm					kN	kg		–	
16	7,8	–	–	7	2,51	0,009	–	RSTO 5 TN	–
	7,8	–	–	7	2,51	0,009	–	RSTO 5 XTN	–
19	9,8	10	6	10	3,74	0,013	0,017	RSTO 6 TN	STO 6 TN
	9,8	10	6	10	3,74	0,013	0,017	RSTO 6 XTN	STO 6 XTN
24	9,8	10	8	12	4,13	0,021	0,026	RSTO 8 TN	STO 8 TN
	9,8	10	8	12	4,13	0,021	0,026	RSTO 8 XTN	STO 8 XTN
30	11,8	12	10	14	8,25	0,042	0,049	RSTO 10	STO 10
	11,8	12	10	14	8,25	0,042	0,049	–	STO 10 XTN
32	11,8	–	–	16	8,8	0,049	–	RSTO 12	–
35	11,8	12	15	20	9,13	–	0,063	–	STO 15
40	15,8	16	17	22	14,2	–	0,11	–	STO 17 X
47	15,8	16	20	25	16,1	–	0,15	–	STO 20
52	15,8	16	25	30	16,5	–	0,18	–	STO 25
	15,8	16	25	30	16,5	–	0,18	–	STO 25 X
62	19,8	20	30	38	22,9	–	0,31	–	STO 30

Support rollers without axial guidance

with seals

D 19–90 mm

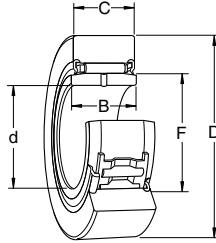

Dimensions					Basic load rating Support roller dynamic C	Masses		Designations	
D	C	B	d	F		RNA	NA	Support roller without inner ring	with inner ring
mm					kN	kg		–	
19	11,8	12	6	10	3,52	0,018	0,022	RNA 22/6.2RS	NA 22/6.2RS
24	11,8	12	8	12	4,46	0,029	0,034	RNA 22/8.2RS	NA 22/8.2RS
30	13,8	14	10	14	6,44	–	0,060	–	NA 2200.2RS
32	13,8	14	12	16	6,93	–	0,067	–	NA 2201.2RS
35	13,8	14	15	20	7,21	0,060	0,075	RNA 2202.2RS	NA 2202.2RS
	13,8	14	15	20	7,21	0,060	0,075	–	NA 2202.2RSX
40	15,8	16	17	22	9,35	0,094	0,11	RNA 2203.2RS	NA 2203.2RS
	15,8	16	17	22	9,35	0,094	0,11	–	NA 2203.2RSX
47	17,8	18	20	25	15,4	0,15	0,18	RNA 2204.2RS	NA 2204.2RS
52	17,8	18	25	30	16,1	–	0,21	–	NA 2205.2RS
	17,8	18	25	30	16,1	–	0,21	–	NA 2205.2RSX
62	19,8	20	30	35	17,6	–	0,32	–	NA 2206.2RS
72	22,7	23	35	42	22	–	0,51	–	NA 2207.2RS
80	22,7	23	40	48	27	–	0,63	–	NA 2208.2RS
90	22,7	23	50	58	27	–	0,69	–	NA 2210.2RS



Support rollers with axial guidance

D 16–62 mm

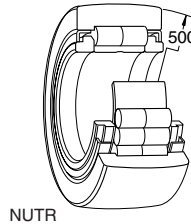
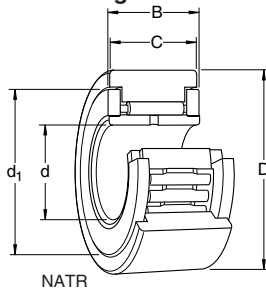

Dimensions					Basic load rating Support roller dynamic C	Mass kg	Designations	
D	C	B	d	d ₁			Support roller with crowned runner surface	cylindrical runner
mm					kN	kg	–	
16	11	12	5	12	3,14	0,014	NATR 5	NATR 5 X
	11	12	5	12	3,14	0,014	NATR 5 PP	NATR 5 PPX
	11	12	5	12	4,73	0,015	NATV 5	–
	11	12	5	12	4,73	0,015	NATV 5 PP	–
19	11	12	6	14	3,47	0,020	NATR 6	NATR 6 X
	11	12	6	14	3,47	0,020	NATR 6 PP	NATR 6 PPX
	11	12	6	14	5,28	0,021	NATV 6	–
	11	12	6	14	5,28	0,021	NATV 6 PP	NATV 6 PPX
24	14	15	8	19	5,28	0,041	NATR 8	NATR 8 X
	14	15	8	19	5,28	0,041	NATR 8 PP	NATR 8 PPX
	14	15	8	19	7,48	0,042	NATV 8	–
	14	15	8	19	7,48	0,042	NATV 8 PP	NATV 8 PPX
30	14	15	10	23	6,44	0,064	NATR 10	NATR 10 X
	14	15	10	23	6,44	0,064	NATR 10 PP	NATR 10 PPX
	14	15	10	23	8,97	0,065	NATV 10	–
	14	15	10	23	8,97	0,065	NATV 10 PP	NATV 10 PPX
32	14	15	12	25	6,6	0,071	NATR 12	NATR 12 X
	14	15	12	25	6,6	0,071	NATR 12 PP	NATR 12 PPX
	14	15	12	25	9,35	0,072	NATV 12	–
	14	15	12	25	9,35	0,072	NATV 12 PP	NATV 12 PPX
35	18	19	15	27	9,52	0,10	NATR 15	–
	18	19	15	27	9,52	0,10	NATR 15 PP	NATR 15 PPX
	18	19	15	27	12,3	0,11	NATV 15	–
	18	19	15	27	12,3	0,11	NATV 15 PP	NATV 15 PPX
	18	19	15	20	16,8	0,10	NUTR 15	NUTR 15 X
40	20	21	17	32	10,5	0,14	NATR 17	NATR 17 X
	20	21	17	32	10,5	0,14	NATR 17 PP	NATR 17 PPX
	20	21	17	32	14,2	0,15	NATV 17	–
	20	21	17	32	14,2	0,15	NATV 17 PP	NATV 17 PPX
	20	21	17	22	19	0,15	NUTR 17	NUTR 17 X
42	18	19	15	20	20,1	0,16	NUTR 1542	NUTR 1542 X
47	20	21	17	22	22	0,22	NUTR 1747	NUTR 1747 X
	24	25	20	37	14,7	0,25	NATR 20	–
	24	25	20	37	14,7	0,25	NATR 20 PP	NATR 20 PPX
	24	25	20	37	19,4	0,26	NATV 20 PP	NATV 20 PPX
	24	25	20	27	28,6	0,25	NUTR 20	NUTR 20 X
52	24	25	20	27	31,9	0,32	NUTR 2052	NUTR 2052 X
	24	25	25	42	14,7	0,28	NATR 25	NATR 25 X
	24	25	25	42	14,7	0,28	NATR 25 PP	NATR 25 PPX
	24	25	25	42	19,8	0,29	NATV 25	–
	24	25	25	42	19,8	0,29	NATV 25 PP	NATV 25 PPX
	24	25	25	31	29,7	0,28	NUTR 25	NUTR 25 X
62	24	25	25	31	35,8	0,45	NUTR 2562	NUTR 2562 X
	28	29	30	51	22,9	0,47	NATR 30	–
	28	29	30	51	22,9	0,47	NATR 30 PP	NATR 30 PPX

Support rollers with axial guidance

D 62–110 mm

Dimensions					Basic load rating Support roller dynamic C	Mass	Designations	
D	C	B	d	d ₁			Support roller with crowned runner surface	cylindrical runner surface
mm					kN	kg	–	
62 (cont.)	28	29	30	51	29,2	0,48	NATV 30	–
	28	29	30	51	29,2	0,48	NATV 30 PP	NATV 30 PPX
	28	29	30	38	41,3	0,47	NUTR 30	NUTR 30 X
72	28	29	30	38	48,4	0,70	NUTR 3072	NUTR 3072 X
	28	29	35	58	24,6	0,64	NATR 35	–
	28	29	35	58	24,6	0,64	NATR 35 PP	NATR 35 PPX
	28	29	35	58	31,9	0,65	NATV 35 PP	–
	28	29	35	44	45,7	0,63	NUTR 35	NUTR 35 X
80	28	29	35	44	51,2	0,84	NUTR 3580	NUTR 3580 X
	30	32	40	66	31,9	0,80	NATR 40	–
	30	32	40	66	31,9	0,80	NATR 40 PP	NATR 40 PPX
	30	32	40	66	39,1	0,89	NATV 40	–
	30	32	40	66	39,1	0,89	NATV 40 PP	NATV 40 PPX
	30	32	40	51	57,2	0,82	NUTR 40	NUTR 40 X
85	30	32	45	55	58,3	0,88	NUTR 45	NUTR 45 X
90	30	32	40	51	68,2	1,15	NUTR 4090	NUTR 4090 X
	30	32	50	76	30,8	0,96	NATR 50	–
	30	32	50	76	30,8	0,96	NATR 50 PP	NATR 50 PPX
	30	32	50	76	39,1	1,00	NATV 50 PP	–
	30	32	50	60	58,3	0,95	NUTR 50	NUTR 50 X
100	30	32	45	55	73,7	1,40	NUTR 45100	NUTR 45100 X
110	30	32	50	60	78,1	1,70	NUTR 50110	NUTR 50110 X



Cam followers

D 16–62 mm

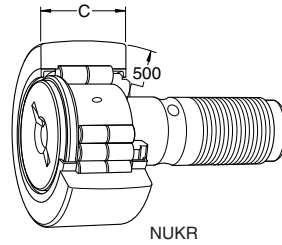
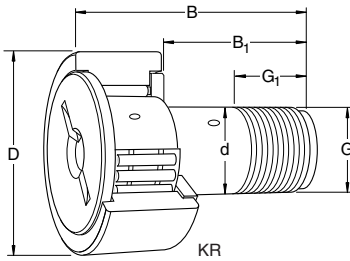

Dimensions								Basic load rating Cam follower dynamic C	Mass	Designations	
D	C	d	B	B ₁	G	G ₁	Cam follower with crowned runner surface			cylindrical runner surface	
mm								kN	kg	–	
16	11	6	28	16	M 6	8	3,14	0,018	KR 16	KR 16 X	
							3,14	0,018	KR 16 PP	KR 16 PPX	
							4,73	0,020	KRV 16	–	
							4,73	0,020	KRV 16 PP	–	
19	11	8	32	20	M 8	10	3,47	0,028	KR 19	KR 19 X	
							3,47	0,028	KR 19 PP	KR 19 PPX	
							5,28	0,032	KRV 19	–	
							5,28	0,032	KRV 19 PP	–	
22	12	10	36	23	M 10×1	12	4,4	0,044	KR 22	KR 22 X	
							4,4	0,044	KR 22 PP	KR 22 PPX	
							6,05	0,045	KRV 22	–	
							6,05	0,045	KRV 22 PP	–	
26	12	10	36	23	M 10×1	12	4,84	0,058	KR 26	–	
							4,84	0,058	KR 26 PP	KR 26 PPX	
							6,82	0,061	KRV 26	–	
							6,82	0,061	KRV 22 PP	–	
30	14	12	40	25	M 12×1,5	13	6,44	0,087	KR 30	KR 30 X	
							6,44	0,087	KR 30 PP	KR 30 PPX	
							8,97	0,089	KRV 30	–	
							8,97	0,089	KRV 30 PP	–	
32	14	12	40	25	M 12×1,5	13	6,71	0,098	KR 32	–	
							6,71	0,098	KR 32 PP	KR 32 PPX	
							9,35	0,10	KRV 32	–	
							9,35	0,10	KRV 32 PP	–	
35	18	16	52	32,5	M 16×1,5	17	9,52	0,17	KR 35	–	
							9,52	0,17	KR 35 PP	KR 35 PPX	
							12,3	0,17	KRV 35	–	
							12,3	0,17	KRV 35 PP	–	
							16,8	0,16	NUKR 35	NUKR 35 X	
40	20	18	58	36,5	M 18×1,5	19	10,5	0,25	KR 40	–	
							10,5	0,25	KR 40 PP	KR 40 PPX	
							14,2	0,25	KRV 40	–	
							14,2	0,25	KRV 40 PP	–	
							19	0,24	NUKR 40	NUKR 40 X	
47	24	20	66	40,5	M 20×1,5	21	14,7	0,39	KR 47	–	
							14,7	0,39	KR 47 PP	–	
							19,4	0,39	KRV 47 PP	–	
							28,6	0,38	NUKR 47	–	
52	24	20	66	40,5	M 20×1,5	21	15,7	0,46	KR 52	–	
							15,7	0,46	KR 52 PP	KR 52 PPX	
							20,9	0,47	KRV 52 PP	–	
							29,7	0,45	NUKR 52	NUKR 52 X	
62	29	24	80	49,5	M 24×1,5	25	24,6	0,79	KR 62	–	
							24,6	0,79	KR 62 PP	–	
							31,4	0,80	KRV 62	–	
							31,4	0,80	KRV 62 PP	–	
							41,3	0,80	NUKR 62	–	

Cam followers

D 72–90 mm

Dimensions								Basic load rating Cam follower dynamic C	Mass Cam follower	Designations	
D	C	d	B	B ₁	G	G ₁	Cam follower with crowned runner surface			cylindrical runner surface	
mm								kN	kg	–	
72	29	24	80	49,5	M 24×1,5	25	26	1,05	KR 72	–	
							26	1,05	KR 72 PP	–	
							33	1,05	KRV 72 PP	–	
							45,7	1,05	NUKR 72	–	
80	35	30	100	63	M 30×1,5	32	36,9	1,55	KR 80	–	
							36,9	1,55	KR 80 PP	–	
							69,3	1,60	NUKR 80	–	
90	35	30	100	63	M 30×1,5	32	38	1,95	KR 90 PP	–	
							47,3	1,95	KRV 90 PP	–	
							78,1	2,00	NUKR 90	–	

Y-bearings

Y-bearings are basically deep groove ball bearings which are filled with grease and sealed at both sides. The outer ring has a sphered outside diameter and together with the concave sphered seating in the housing enables initial errors of alignment to be compensated for. The special bore tolerance, extended inner ring and eccentric locking collar or grub screw locking simplify mounting and dismantling and commercial drawn shafting can be used.

The particular advantages of SKF Y-bearings include

- robust quality,
- highly efficient seals,
- long life grease fill, and
- long service life.

The price/performance ratio is also favourable.

Range

The popular range of SKF Y-bearings comprises two bearing series with grub screw locking and two with eccentric locking collar. The series differ in the width of the inner ring. Bearings with grub screw locking are available in series YAR, YAJ (1) and YAT (2), bearings with eccentric locking collar in series YEL (3) and YET (4). In contrast to the other Y-bearings, those of series 17262(00)-2RS1 (5) have a standard inner ring with the same bore tolerances as for standard deep groove ball bearings.

The SKF Y-bearing range also includes bearings with adapter sleeve as well as inch sizes of the first four series described above.

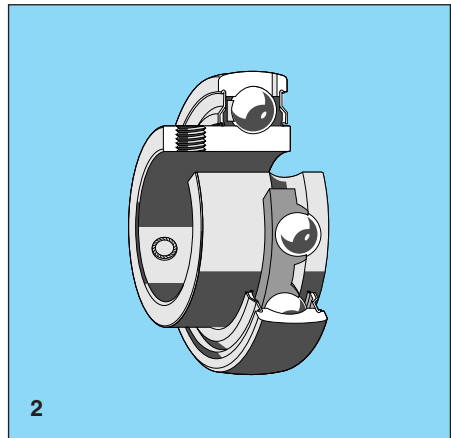
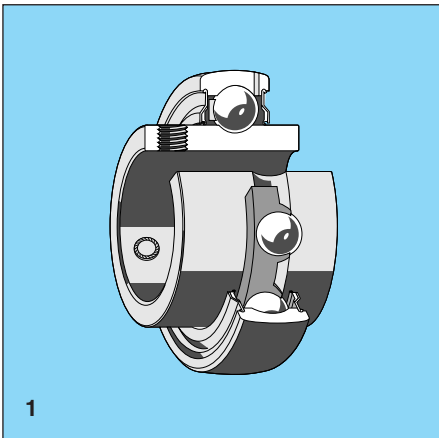

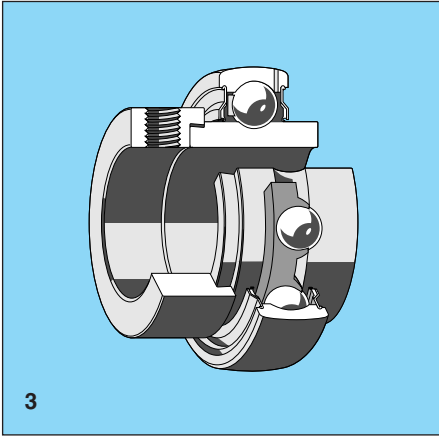

3

Dimensions

The dimensions of the Y-bearings with eccentric locking ring and grub screw locking are in accordance with ISO 2264-1974 and ISO 3145-1975, where applicable. The dimensions of the bearings with standard inner rings are to ISO 15-1981.

Tolerances

The bore of SKF Y-bearings with eccentric locking ring and grub screw locking is machined to $(H6 + H7)/2$ to allow for easy mounting. The bearings with standard inner ring are made to Normal tolerances according to ISO 492:1994.

Internal clearance

SKF Y-bearings with eccentric locking ring and grub screw locking have Normal radial internal clearance in accordance with ISO 9628:1992. Bearings with standard inner ring have Normal radial internal clearance to ISO 5753:1991.

Cages

SKF Y-bearings have a moulded glass fibre reinforced polyamide 6,6 cage. The maximum operating temperature for the cage is the same as for the seals, i.e. +110 °C.

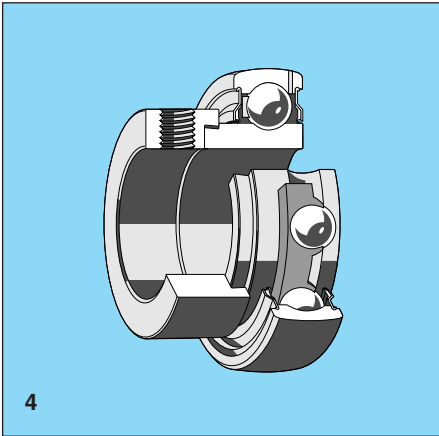

4

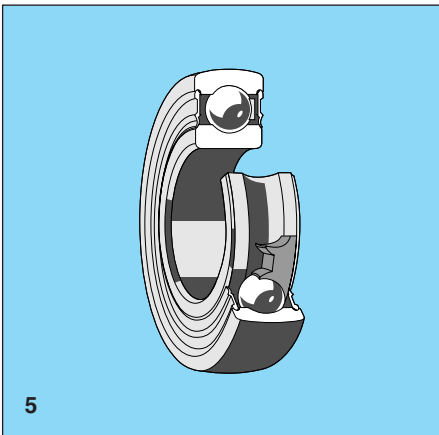

5

3

Y-bearings

Seals and grease fill

The seals of SKF Y-bearings merit special attention. Depending on the bearing up to three designs are available.

The standard seal consists of a pressed steel washer on the inside of which a synthetic rubber sealing lip is vulcanised. The steel washer forms a narrow gap to the inner ring shoulder (land) and provides protection to the lip against coarse contaminants (1).

For difficult operating conditions, the bearings with wide inner rings (extended at both sides) can be supplied with flingers which are mounted outside the seals (2).

For even more arduous conditions, where reliable operation is required, bearings with heavy-duty RF seals can be supplied. These have a second sealing lip vulcanised to the flinger which seals axially against the standard seal (3).

Y-bearings with standard inner ring, series 17262(00)-2RS1, are fitted with the standard RS1 seals of deep groove ball bearings.

All Y-bearings are filled as standard with a lithium base grease. It has good rust inhibiting properties and can be used at temperatures from -30 to $+110$ °C. For maintenance-free bearing arrangements bearings with RF seals and filled with a lithium/calcium base “long-life” grease are ideal.

Supplementary designations

The suffixes which are frequently used for SKF Y-bearings are explained in the following.

GFA	“Food” quality aluminium complex grease with mineral and synthetic oil base
-2F	Pressed steel flingers at both sides of bearing
HV	Stainless steel bearing rings (grease is as under GFA but suffix GFA is omitted)
-2RS1	Synthetic rubber seal (rubbing seal) with sheet steel reinforcement at both sides of bearing
-2RF	Pressed steel flingers with synthetic rubber axial sealing lip at both sides of bearing
-2RFW	-2RF + W
W	No lubrication holes in outer ring

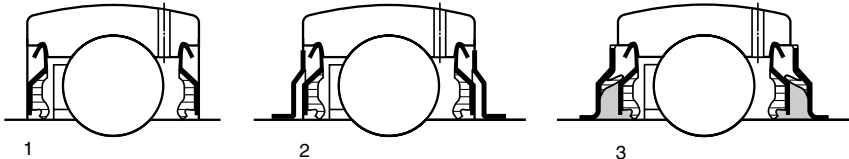

Y-bearings with grub screw locking
d 17–100 mm

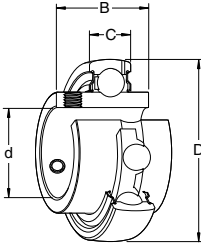

Dimensions	Basic load rating dynamic C	Mass	Designation	Dimensions		
				d	D	C
mm	kN	kg	–			
17	40	22,1	12	7,35	0,074	YAT 203
	40	27,4	12	7,35	0,088	YAR 203-2F
20	47	25,5	14	9,8	0,11	YAT 204
	47	31	14	9,8	0,14	YAR 204-2F
	47	31	14	9,8	0,14	YAR 204-2RF
	47	31	14	9,8	0,14	YAR 204-2RFW
25	52	27,2	15	10,8	0,14	YAT 205
	52	34,1	15	10,8	0,17	YAR 205-2F
	52	34,1	15	10,8	0,17	YAR 205-2RF
	52	34,1	15	10,8	0,17	YAR 205-2RFW
30	62	30,2	18	15	0,23	YAT 206
	62	38,1	18	15	0,28	YAR 206-2F
	62	38,1	18	15	0,28	YAR 206-2RF
	62	38,1	18	15	0,28	YAR 206-2RFW
35	72	33	19	19,6	0,31	YAT 207
	72	42,9	19	19,6	0,41	YAR 207-2F
	72	42,9	19	19,6	0,41	YAR 207-2RF
	72	42,9	19	19,6	0,41	YAR 207-2RFW
40	80	36	21	23,6	0,43	YAT 208
	80	49,2	21	23,6	0,55	YAR 208-2F
	80	49,2	21	23,6	0,55	YAR 208-2RF
	80	49,2	21	23,6	0,55	YAR 208-2RFW
45	85	37	22	25,5	0,48	YAT 209
	85	49,2	22	25,5	0,60	YAR 209-2F
	85	49,2	22	25,5	0,60	YAR 209-2RF
50	90	38,8	22	27	0,54	YAT 210
	90	51,6	22	27	0,69	YAR 210-2F
	90	51,6	22	27	0,69	YAR 210-2RF
55	100	55,6	25	33,5	0,94	YAR 211-2F
	100	55,6	25	33,5	0,94	YAR 211-2RF
60	110	65,1	26	40,5	1,30	YAR 212-2F
	110	65,1	26	40,5	1,30	YAR 212-2RF
65	120	68,3	27	44	1,70	YAR 213-2F
	120	68,3	27	44	1,70	YAR 213-2RF
70	125	74,6	28	46,5	1,90	YAJ 214-2RF
80	140	82,6	30	54	2,80	YAJ 216-2RF
90	160	96,0	36	73,5	4,10	YAJ 218-2RF
100	180	108	40	95	5,65	YAJ 220-2RF

Y-bearings with eccentric locking collar
d 17–60 mm

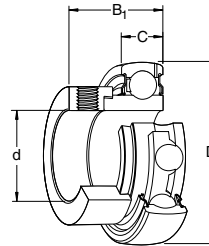

Dimensions	Basic load rating dynamic C	Mass	Designation	Dimensions		
				d	D	B ₁
mm	kN	kg	–			
17	40	28,6	12	7,35	0,10	YET 203
	47	31	14	9,8	0,16	YET 204
20	47	31	14	9,8	0,16	YET 204 W
	47	43,7	14	9,8	0,19	YEL 204
	47	43,7	14	9,8	0,19	YEL 204-2RF
	47	43,7	14	9,8	0,19	YEL 204-2RF
25	52	31	15	10,8	0,18	YET 205
	52	31	15	10,8	0,18	YET 205 W
	52	44,4	15	10,8	0,23	YEL 205
	52	44,4	15	10,8	0,23	YEL 205-2RF
30	62	35,7	18	15	0,30	YET 206
	62	35,7	18	15	0,30	YET 206 W
	62	48,4	18	15	0,36	YEL 206
	62	48,4	18	15	0,36	YEL 206-2RF
35	72	38,9	19	19,6	0,44	YET 207
	72	38,9	19	19,6	0,44	YET 207 W
	72	51,1	19	19,6	0,52	YEL 207
	72	51,1	19	19,6	0,52	YEL 207-2RF
40	80	43,7	21	23,6	0,59	YET 208
	80	43,7	21	23,6	0,59	YET 208 W
	80	46,3	21	23,6	0,67	YEL 208
	80	46,3	21	23,6	0,67	YEL 208-2RF
45	85	43,7	22	25,5	0,65	YET 209
	85	56,3	22	25,5	0,74	YEL 209
	85	56,3	22	25,5	0,74	YEL 209-2RF
50	90	43,7	22	27	0,73	YET 210
	90	62,7	22	27	0,89	YEL 210
	90	62,7	22	27	0,89	YEL 210-2RF
55	100	48,4	25	33,5	0,98	YET 211
	100	71,4	25	33,5	1,20	YEL 211
60	110	77,8	26	40,5	1,60	YEL 212



Y-bearings with standard inner ring
d 15–50 mm

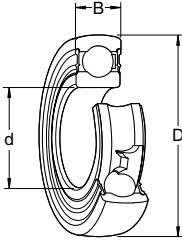

Dimensions			Basic load rating dynamic C	Mass	Designation
d	D	B			
mm			kN	kg	–
15	35	11	7,8	0,039	1726202-2RS1
17	40	12	9,56	0,056	1726203-2RS1
20	47	14	12,7	0,095	1726204-2RS1
25	52	15	14	0,11	1726205-2RS1
30	62	16	19,5	0,18	1726206-2RS1
35	72	17	25,5	0,25	1726207-2RS1
40	80	18	30,7	0,32	1726208-2RS1
45	85	19	33,2	0,37	1726209-2RS1
50	90	20	35,1	0,41	1726210-2RS1

Y-bearing units

Y-bearing units consist of a Y-bearing, see page 130, and a Y-bearing housing of cast iron, pressed steel or composite material. Because of the sphered surfaces of the contact between bearing and housing, Y-bearing units can compensate for relatively large initial errors of alignment. They do not, however, permit axial displacement and are not, therefore, suitable for non-locating bearing positions. The distance between bearing positions should therefore be small, or the housings mounted on resilient sheet metal walls to prevent inadmissible stressing of the bearings, e.g. when thermal elongation of the shaft occurs.

Most of the Y-bearings and Y-bearing housings available from SKF can be combined together, thus allowing the optimum Y-bearing unit for any given application to be selected. SKF Y-bearing units can therefore solve many bearing arrangement problems. They are robust, reliable and last a long time. They are also easy to install, are well sealed, and offer a very favourable price/performance ratio.

SKF Y-TECH bearing units represent a new performance class where ready-to-mount bearing units are concerned. The composite housings of these units are corrosion resistant. The bearings are maintenance-free and are filled with a special long-life grease.

Range

SKF Y-bearing units are available as plummer block, flanged, and take-up units. The overview on page 137 shows the various possible combinations of bearing and housing. The Y-bearing units shown on a blue background belong to the SKF standard range; those on a white background are available to special order.

SKF cast iron Y-bearing housings are in one piece and have a grease nipple and lubrication groove in the housing bore. Y-bearing

units with lubrication hole(s) can be relubricated when mounted in these cast iron housings.

SKF pressed steel Y-bearing housings are in two parts and relubrication is not possible. They are zinc coated to prevent corrosion. With SKF Y-bearing units having pressed steel housings, the bearings and two-part housings are supplied and should be ordered separately.

SKF Y-TECH bearing units are state-of-the-art products. The form-stable composite housings and bearings fitted with the highly efficient RF seals and filled with a special long-life grease make the units maintenance-free. No relubrication is required. Y-TECH plummer block units (SYK) and bearing units with flanged housings (FYK, FYTBK) belong to the SKF popular bearing range.

End covers

To protect bearing arrangements at the ends of shafts and to eliminate the risk of accidents with free shaft ends, end covers of series ECY 2 are available for Y-bearing units with cast iron or composite housings. The covers are of plastic and can be snapped into recesses in the housing bore which are provided for this purpose.













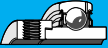

Y-bearing units

Rubber inserts

To reduce running noise and to damp vibrations, synthetic rubber inserts, series RIS 2, are available. These inserts also allow the bearings a certain amount of “freedom” in the housing, e.g. to compensate for thermal elongation of the shaft. The various components of the units with rubber insert, i.e. housing, bearing and insert, must be ordered separately, see page 140.

Dimensions

The dimensions of the Y-bearing plummer block and flanged housings, where standardised, conform to ISO 3228-1977 with the exception of the shaft centre height of the pressed steel plummer block housings which deviate slightly from the standard. The dimensions of the Y-bearing take-up housings are in accordance with ISO 3228-1977.

	 YAR 2-2F YAR 2-2RF YAJ 2-2RF		 YET 2	 YEL 2 YEL 2-2RF		 YAT 2
 SY(J)	SY(J)-TF	SY(J)-TR	SY-FM	SY-WM	SY-WR	SY-RM
 SYK	SYK-TF	SYK-TR	SYK-FM			
 P	P-TF	P-TR	P-FM	P-WM	P-WR	P-RM
 FY(J)	FY(J)-TF	FY(J)-TR	FY-FM	FY-WM	FY-WR	FY-RM
 FYK	FYK-TF	FYK-TR	FYK-FM			
 FYTB	FYTB-TF	FYTB-TR	FYTB-FM	FYTB-WM	FYTB-WR	FYTB-RM
 FYTBK	FYTBK-TF	FYTBK-TR	FYTBK-FM			
 PFT	PFT-TF	PFT-TR	PFT-FM	PFT-WM	PFT-WR	PFT-RM
 PF	PF-TF	PF-TR	PF-FM	PF-WM	PF-WR	PF-RM
 PFD	PFD-TF	PFD-TR	PFD-FM	PFD-WM	PFD-WR	PFD-RM
 TU	TU-TF		TU-FM			

**Y-bearing plummer block units
with cast or composite housing
d 17–35 mm**

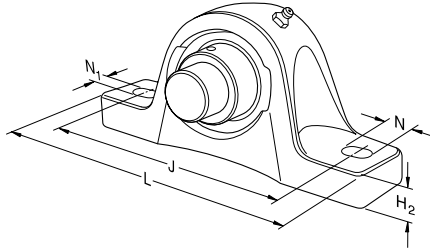
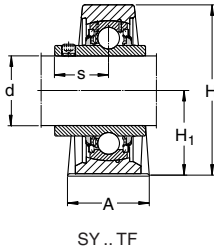

Dimensions											Bearing load rating dynamic C	Mass	Designation	Appropriate end cover Designation	
d	A	H	H ₁	H ₂	J min	J max	L	N	N ₁	s					
mm											kN	kg	–	–	
17	32	56	30,2	14	88	106	127	20,5	11,5	15,9	7,35	0,50	SY 17 TF	–	
										22,1	7,35	0,52	SY 17 FM	–	
										23,4	7,35	0,54	SY 17 WM	–	
20	32	64	33,3	14	88	106	127	20,5	11,5	18,3	9,8	0,57	SY 20 TF	ECY 204	
										23,5	9,8	0,59	SY 20 FM	ECY 204	
										26,6	9,8	0,62	SY 20 WM	ECY 204	
	32	63,8	33,3	14	88	106	127	20,5	12	18,3	9,8	0,57	SYJ 20 TF	ECY 204	
		64	33,3	16	80	113	126	17	11,5	18,3	9,8	0,24	SYK 20 TF	ECY 204	
	25	36	70	36,5	16	94	110	130	19,5	11,5	18,3	9,8	0,24	SYK 20 TR	ECY 204
											18,3	9,8	0,24	SYK 20 FM	ECY 204
23,5											9,8	0,26			
36		69,5	36,5	16	93	112	133	21,5	12	19,8	10,8	0,72	SY 25 TF	ECY 205	
		70,5	36,5	16	88	122	134	17	11,5	19,8	10,8	0,29	SYK 25 TF	ECY 205	
30	40	82	42,9	17	108	127	152	23,5	14	22,2	15	1,10	SY 30 TF	ECY 206	
										22,2	15	1,10	SY 30 TR	ECY 206	
										26,7	15	1,10	SY 30 FM	ECY 206	
	40	81,5	42,9	17	110	126	153	24	16	30,1	15	1,20	SY 30 WM	ECY 206	
										22,2	15	1,10	SYJ 30 TF	ECY 206	
	40	82	42,9	19	100	142	159	21	14	22,2	15	0,49	SYK 30 TF	ECY 206	
										22,2	15	0,49	SYK 30 TR	ECY 206	
											26,7	15	0,50	SYK 30 FM	ECY 206
	35	45	93	47,6	19	119	133	160	21	14	25,4	19,6	1,45	SY 35 TF	ECY 207
25,4											19,6	1,45	SY 35 TR	ECY 207	
29,4											19,6	1,55	SY 35 FM	ECY 207	
45		92,1	47,6	19	121	136	166	23,5	16	32,3	19,6	1,60	SY 35 WM	ECY 207	
										25,4	19,6	1,45	SYJ 35 TF	ECY 207	
45		93	47,6	19	105	147	164	21	14	25,4	19,6	0,66	SYK 35 TF	ECY 207	
										25,4	19,6	0,66	SYK 35 TR	ECY 207	
										29,4	19,6	0,68	SYK 35 FM	ECY 207	

**Y-bearing plummer block units
with cast or composite housing
d 40–100 mm**

Dimensions											Bearing load rating dynamic C	Mass	Designation	Appropriate end cover Designation
d	A	H	H ₁	H ₂	J min	J max	L	N	N ₁	s				
mm											kN	kg	–	–
40	48	99	49,2	19	125	146	175	24,5	14	30,2	23,6	1,80	SY 40 TF	ECY 208
											23,6		SY 40 TR	ECY 208
											23,6		SY 40 FM	ECY 208
											34,9		SY 40 VM	ECY 208
	48	98,2	49,2	19	127	146	177	25,5	16	30,2	23,6	1,80	SYJ 40 TF	ECY 208
											23,6		SYK 40 TF	ECY 208
48	99	49,2	19	115	157	176	21	14	30,2	23,6	0,86	SYK 40 TR	ECY 208	
										23,6		SYK 40 FM	ECY 208	
45	48	107	54	21	135	152	187	22,5	14	30,2	25,5	2,20	SY 45 TF	ECY 209
											25,5		SY 45 TR	ECY 209
											25,5		SY 45 FM	ECY 209
											34,9		SY 45 WM	ECY 209
50	54	114	57,2	22	149	165	203	26	18	32,6	27	2,70	SY 50 TF	ECY 210
											27		SY 50 TR	ECY 210
											27		SY 50 FM	ECY 210
											38,1		SY 50 WM	ECY 210
55	60	125	63,5	24	162	181	219	27,5	18	33,4	33,5	3,60	SY 55 TF	–
											33,5		SY 55 FM	–
											43,6		SY 55 WM	–
60	60	137	69,9	26,5	179	202	240	29,5	18	39,7	40,5	4,45	SY 60 TF	–
											40,5		SY 60 TR	–
											40,5		SY 60 WM	–
65	65	150	76,2	29	190	216	257	35	22	42,9	44	5,70	SY 65 TF	–
70	65	155	79,4	29	202	218	260	30	22	44,4	46,5	6,40	SYJ 70 TR	–
80	78	175	88,9	30	219	245	290	35	22	49,3	54	9,70	SYJ 80 TR	–
90	88	200	101,6	34	253	271	327	35	26	56,3	73,5	13,8	SYJ 90 TR	–
100	95	225	115	38	286	330	380	48	26	66	95	19,0	SYJ 100 TR	–

**Y-bearing plummer block units
with pressed steel housing**
d 17–45 mm

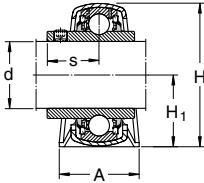

P + YAR

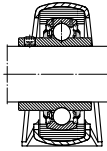

P + YAR + RIS

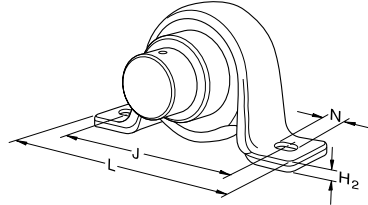

Dimensions										Bearing load rating dynamic C	Permissible Mass housing load radial		Designations for ordering Housing+bearing+rubber seating ring	
d	A	H	H ₁	H ₂	J	L	N	s			kN	kg	–	–
17	26	44	22	3	68	86	9,6	22,1	7,35	1,25	0,18	P 40	YET 203	
20	32	50	25,2	3	76	99	9,6	18,3	9,8	1,7	0,22	P 47	YAR 204-2F	
	32	56	28,3	3,2	86	108	11,2	23,5	9,8	1,7	0,24	P 47	YET 204	
										1,8	0,28	P 52	YET 204	RIS 204
25	32	56	28,3	3,2	86	108	11,2	19,6	10,8	1,8	0,27	P 52	YAR 205-2F	
								23,5	10,8	1,8	0,28	P 52	YET 205	
	38	66	32,9	4	95	119	11,2	23,5	10,8	2,6	0,39	P 62	YET 205	RIS 205
30	38	66	32,9	4	95	119	11,2	22,2	15	2,6	0,47	P 62	YAR 206-2F	
								26,7	15	2,6	0,45	P 62	YET 206	
	41	78	39,2	5	106	130	11,2	26,7	15	3,3	0,60	P 72	YET 206	RIS 206 A
35	41	78	39,2	5	106	130	11,2	25,4	19,6	3,3	0,67	P 72	YAR 207-2F	
								29,4	19,6	3,3	0,75	P 72	YET 207	
	43	86	43,5	5	120	148	14	29,4	19,6	3,8	0,89	P 80	YET 207	RIS 207 A
40	43	86	43,5	5	120	148	14	30,2	23,6	3,8	0,92	P 80	YAR 208-2F	
								32,7	23,6	3,8	0,99	P 80	YET 208	
	45	92	46,4	6	128	156	14	32,7	23,6	4,2	1,05	P 85	YET 208	RIS 208 A
45	45	92	46,4	6	128	156	14	30,2	25,5	4,2	1,00	P 85	YAR 209-2F	
								32,7	25,5	4,2	1,05	P 85	YET 209	

**Y-bearing flanged units
with square cast or composite housing
d 17–35 mm**

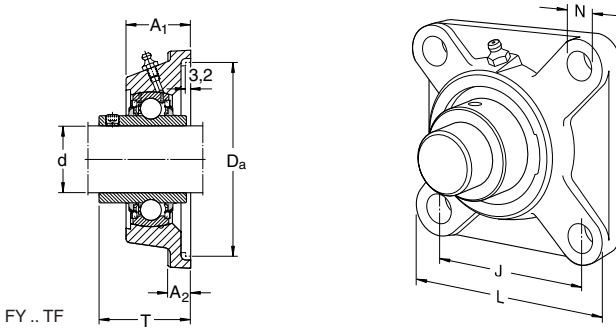

Dimensions								Bearing load rating dynamic C	Mass	Designation	Appropriate end cover Designation	
d	A ₁	A ₂	D _a	J	L	N	T					
mm								kN	kg	–	–	
17	26	11	55,6	54	76	11,5	32,9	7,35	0,44	FY 17 TF	–	
							40,4	7,35	0,48	FY 17 WM	–	
20	29,5	11	68,3	63,5	86	11,5	37,3	9,8	0,60	FY 20 TF	ECY 204	
							42,5	9,8	0,62	FY 20 FM	ECY 204	
							45,6	9,8	0,65	FY 20 WM	ECY 204	
	30	15	68,3	63,5	86	11,5	33,3	9,8	0,58	FYJ 20 TF	ECY 204	
							37,3	9,8	0,26	FYK 20 TF	ECY 204	
							37,3	9,8	0,26	FYK 20 TR	ECY 204	
						42,5	9,8	0,28	FYK 20 FM	ECY 204		
25	30	12	74,6	70	95	11,5	38,8	10,8	0,77	FY 25 TF	ECY 205	
							38,8	10,8	0,77	FY 25 TR	ECY 205	
							42,5	10,8	0,78	FY 25 FM	ECY 205	
							45,9	10,8	0,83	FY 25 WM	ECY 205	
	27	12	74,6	70	95	12	35,8	10,8	0,58	FYJ 25 TF	ECY 205	
							38,8	10,8	0,33	FYK 25 TF	ECY 205	
		31	15	74,6	70	95	11,5	38,8	10,8	0,33	FYK 25 TR	ECY 205
								42,5	10,8	0,34	FYK 25 FM	ECY 205
30	32,5	13	93,7	82,5	108	11,5	42,2	15	1,10	FY 30 TF	ECY 206	
							42,2	15	1,10	FY 30 TR	ECY 206	
							46,7	15	1,10	FY 30 FM	ECY 206	
	31	13	93,7	83	108	12	50,1	15	1,20	FY 30 WM	ECY 206	
							40,2	15	1,20	FYJ 30 TF	ECY 206	
							42,2	15	0,48	FYK 30 TF	ECY 206	
		33	15	93,7	82,5	108	11,5	42,2	15	0,48	FYK 30 TR	ECY 206
								42,2	15	0,48	FYK 30 TR	ECY 206
								46,7	15	0,49	FYK 30 FM	ECY 206
35	34,5	13	106,4	92	118	14	46,4	19,6	1,40	FY 35 TF	ECY 207	
							50,4	19,6	1,50	FY 35 FM	ECY 207	
							51,3	19,6	1,55	FY 35 WM	ECY 207	
	34	13	106,4	92	118	14	44,4	19,6	1,40	FYJ 35 TF	ECY 207	
							46,4	19,6	0,66	FYK 35 TF	ECY 207	
		35	17	106,4	92	118	14	46,4	19,6	0,66	FYK 35 TR	ECY 207
								50,4	19,6	0,68	FYK 35 FM	ECY 207



**Y-bearing flanged units
with square cast or composite housing
d 40–100 mm**

Dimensions								Bearing load rating dynamic C	Mass	Designation	Appropriate end cover Designation							
d	A ₁	A ₂	D _a	J	L	N	T											
mm								kN	kg	–	–							
40	38,5	14	115,9	101,5	130	14	54,2	23,6	1,90	FY 40 TF	ECY 208							
							54,2	23,6	1,90	FY 40 TR	ECY 208							
							56,7	23,6	1,95	FY 40 FM	ECY 208							
	36	14	115,9	102	130	16	58,9	23,6	2,05	FY 40 WM	ECY 208							
							51,2	23,6	1,90	FYJ 40 TF	ECY 208							
							39	17	115,9	101,5	130	14	54,2	23,6	0,87	FYK 40 TF	ECY 208	
							54,2	23,6	0,87	FYK 40 TR	ECY 208							
							56,7	23,6	0,90	FYK 40 FM	ECY 208							
							45	39	14	119,1	105	137	16	54,2	25,5	2,10	FY 45 TF	ECY 209
														56,7	25,5	2,15	FY 45 FM	ECY 209
58,9	25,5	2,25	FY 45 WM	ECY 209														
50	43	15	125,4	111	143	18	60,6	27	2,50	FY 50 TF	ECY 210							
							60,6	27	2,50	FY 50 TR	ECY 210							
							60,7	27	2,55	FY 50 FM	ECY 210							
							66,1	27	2,70	FY 50 WM	ECY 210							
							55	47,5	16	150,8	130	162	18	67,4	33,5	3,60	FY 55 TF	–
64,4	33,5	3,60	FY 55 FM	–														
74,6	33,5	3,85	FY 55 WM	–														
60	52	17	161,9	143	175	18	73,7	40,5	4,60	FY 60 TF	–							
							73,7	40,5	4,60	FY 60 TR	–							
							80,8	40,5	5,00	FY 60 WM	–							
65	52,5	17	161,9	149,5	187	18	76,9	44	5,30	FY 65 TF	–							
70	51	22	161,9	152	193	19	76,1	46,5	6,00	FYJ 70 TR	–							
80	55,5	23	179,4	165	208	22	84,3	54	7,60	FYJ 80 TR	–							
90	65	25	193,7	187	235	22	97,9	73,5	11,5	FYJ 90 TR	–							
100	70	25	215,9	219	265	27	110,1	95	15	FYJ 100 TR	–							

**Y-bearing flanged units
with oval cast or composite housing
d 17–50 mm**

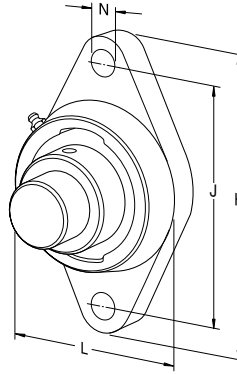
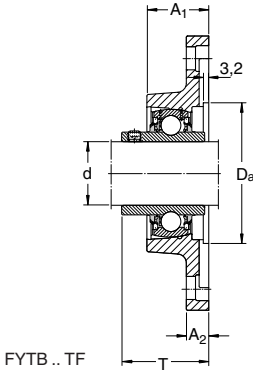

Dimensions									Bearing load rating dynamic C	Mass	Designation	Appropriate end cover Designation
d	A ₁	A ₂	D _a	H	J	L	N	T				
mm									kN	kg	–	–
17	26	11	50,8	98,5	76,5	57	11,5	32,9	7,35	0,39	FYTB 17 TF	–
								39,1	7,35	0,41	FYTB 17 FM	–
								40,4	7,35	0,43	FYTB 17 WM	–
20	29,5	11	50,8	112	90	60,5	11,5	37,3	9,8	0,50	FYTB 20 TF	ECY 204
								37,3	9,8	0,50	FYTB 20 TR	ECY 204
								42,5	9,8	0,52	FYTB 20 FM	ECY 204
	29,5	15	50,8	112	90	60,5	11,5	45,6	9,8	0,55	FYTB 20 WM	ECY 204
								37,3	9,8	0,24	FYTBK 20 TF	ECY 204
								37,3	9,8	0,24	FYTBK 20 TR	ECY 204
								42,5	9,8	0,26	FYTBK 20 FM	ECY 204
25	30	12	63,5	124	99	70	11,5	38,8	10,8	0,63	FYTB 25 TF	ECY 205
								38,8	10,8	0,63	FYTB 25 TR	ECY 205
								42,5	10,8	0,64	FYTB 25 FM	ECY 205
	30	15	63,5	124	99	70	11,5	45,9	10,8	0,69	FYTB 25 WM	ECY 205
								38,8	10,8	0,29	FYTBK 25 TF	ECY 205
								38,8	10,8	0,29	FYTBK 25 TR	ECY 205
								42,5	10,8	0,30	FYTBK 25 FM	ECY 205
30	32,5	13	76,2	141,5	116,5	83	11,5	42,2	15	0,93	FYTB 30 TF	ECY 206
								42,2	15	0,93	FYTB 30 TR	ECY 206
								46,7	15	0,95	FYTB 30 FM	ECY 206
	33	15	76,2	142,5	116,5	83	11,5	50,1	15	1,00	FYTB 30 WM	ECY 206
								42,2	15	0,44	FYTBK 30 TF	ECY 206
								42,2	15	0,44	FYTBK 30 TR	ECY 206
								46,7	15	0,45	FYTBK 30 FM	ECY 206
35	34,5	13	88,9	156	130	96	14	46,4	19,6	1,25	FYTB 35 TF	ECY 207
								50,4	19,6	1,30	FYTB 35 FM	ECY 207
								53,3	19,6	1,40	FYTB 35 WM	ECY 207
	35	17	88,9	156	130	96	14	46,4	19,6	0,61	FYTBK 35 TF	ECY 207
								46,4	19,6	0,61	FYTBK 35 TR	ECY 207
								50,4	19,6	0,63	FYTBK 35 FM	ECY 207
40	38,5	14	88,9	171,5	143,5	102	14	54,2	23,6	1,65	FYTB 40 TF	ECY 208
								54,2	23,6	1,65	FYTB 40 TR	ECY 208
								56,7	23,6	1,70	FYTB 40 FM	ECY 208
								58,9	23,6	1,80	FYTB 40 WM	ECY 208
45	39	14	98,4	178,5	148,5	111	16	54,2	25,5	1,80	FYTB 45 TF	ECY 209
								56,7	25,5	1,85	FYTB 45 FM	ECY 209
								58,9	25,5	1,95	FYTB 45 WM	ECY 209
50	43	15	101,6	189	157	116	18	60,6	27	2,15	FYTB 50 TF	ECY 210
								60,7	27	2,20	FYTB 50 FM	ECY 210
								66,1	27	2,35	FYTB 50 WM	ECY 210

**Y-bearing flanged units
with round pressed steel housing
d 17–50 mm**

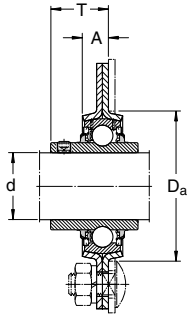

PF + YAR

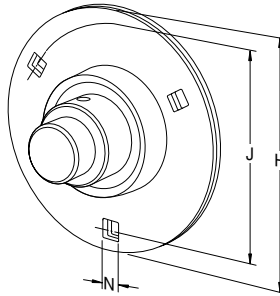

Dimensions							Bearing load rating dynamic C	Permissible housing load radial	Mass	Designations for ordering Housing + bearing	
d	A	Da	H	J	N	T					
mm							kN	kN	kg	–	
17	9	49	81	63	7,1	17,9 24,1	7,35 7,35	2,5 2,5	0,22 0,24	PF 40 PF 40	YAR 203-2F YET 203
20	10	55	91	71,5	8,7	20,3 25,5	9,8 9,8	3,3 3,3	0,30 0,32	PF 47 PF 47	YAR 204-2F YET 204
25	11	60	95	76	8,7	21,8 25,5	10,8 10,8	3,6 3,6	0,35 0,36	PF 52 PF 52	YAR 205-2F YET 205
30	12	71	112	90,5	10,5	24,7 29,2	15 15	5,0 5,0	0,56 0,58	PF 62 PF 62	YAR 206-2F YET 206
35	12,5	81	122	100	11	27,9 31,9	19,6 19,6	6,5 6,5	0,70 0,77	PF 72 PF 72	YAR 207-2F YET 207
40	13,5	91	148	119	13,5	33,7 36,2	23,6 23,6	7,5 7,5	1,20 1,30	PF 80 PF 80	YAR 208-2F YET 208
45	14	97	149	120,6	13,5	33,7 36,2	25,5 25,5	8,3 8,3	1,30 1,35	PF 85 PF 85	YAR 209-2F YET 209
50	15	102	155	127	13,5	36,6 36,7	27 27	9,0 9,0	1,50 1,55	PF 90 PF 90	YAR 210-2F YET 210

**Y-bearing flanged units
with round pressed steel housing**
d 17–35 mm

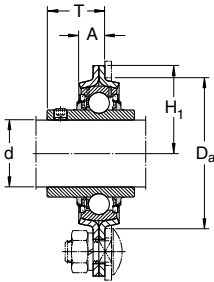

PFD + YAR

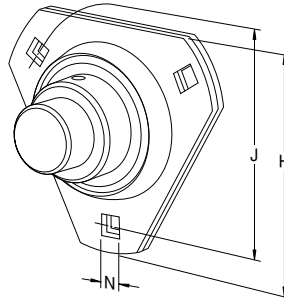

Dimensions								Bearing load rating dynamic C	Permissible housing load radial	Mass	Designations for ordering Housing + bearing
d	A	Da	H	H ₁	J	N	T				
mm								kN	kN	kg	–
17	9	49	81	29	63	7,1	17,9 24,1	7,35 7,35	2,5 2,5	0,17 0,20	PFD 40 YAR 203-2F PFD 40 YET 203
20	10	55	91	32	71,5	8,7	20,3 25,5	9,8 9,8	3,3 3,3	0,26 0,29	PFD 47 YAR 204-2F PFD 47 YET 204
25	11	60	95	34	76	8,7	21,8 25,5	10,8 10,8	3,6 3,6	0,33 0,34	PFD 52 YAR 205-2F PFD 52 YET 205
30	12	71	112	38	90,5	10,5	24,7 29,2	15 15	5,0 5,0	0,47 0,49	PFD 62 YAR 206-2F PFD 62 YET 206
35	12,5	81	122	45	100	11	27,9	19,6	6,5	0,64	PFD 72 YAR 207-2F



**Y-bearing flanged units
with oval pressed steel housing**
d 17–30 mm

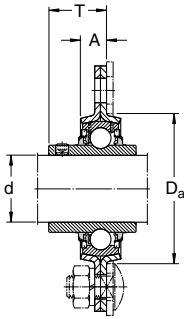

PFT + YAR

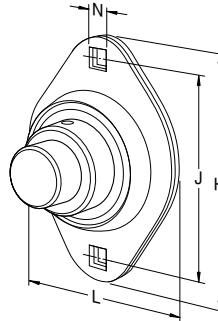

Dimensions								Bearing load rating dynamic C	Permissible housing load radial	Mass	Designations for ordering Housing + bearing	
d	A	D _a	H	L	J	N	T					
mm								kN	kN	kg	–	
17	9	49	81	59	63	7,1	17,9 24,1	7,35 7,35	2,5 2,5	0,17 0,19		PFT 40 PFT 40 YAR 203-2F YET 203
20	10	55	91	67	71,5	8,7	20,3 25,5	9,8 9,8	3,3 3,3	0,23 0,25		PFT 47 PFT 47 YAR 204-2F YET 204
25	11	60	95	71	76	8,7	21,8 25,5	10,8 10,8	3,6 3,6	0,28 0,29		PFT 52 PFT 52 YAR 205-2F YET 205
30	12	71	112	84	90,5	10,5	24,7 29,2	15 15	5,0 5,0	0,44 0,46		PFT 62 PFT 62 YAR 206-2F YET 206

**Y-bearing take-up units
with cast housing**
d 20–55 mm

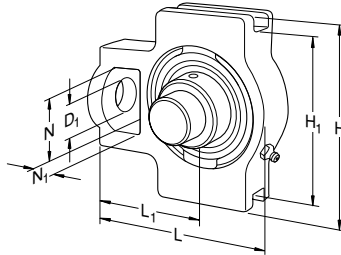
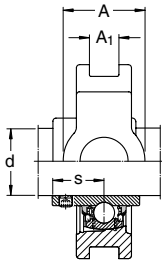

TU .. TF

Dimensions											Bearing load rating dynamic C	Mass	Designation	Appropriate end cover Designation
d	A	A ₁	D ₁	H	H ₁	L	L ₁	N	N ₁	s				
mm											kN	kg	–	–
20	34	13,5	19	92	76	97	62	32	16	18,3	9,8	0,73	TU 20 TF	ECY 204
											23,5			
25	34	13,5	19	91	76	100	64	33	16	19,8	10,8	0,77	TU 25 TF	ECY 205
											23,5			
30	37	13,5	22	104	89	114	70	37	16	22,2	15	1,25	TU 30 TF	ECY 206
											26,7			
35	37	13,5	22	103	89	129	78	38	17	25,4	19,6	1,45	TU 35 TF	ECY 207
											29,4			
40	49	17,5	29	115	101	145	88	50	19	30,2	23,6	2,30	TU 40 TF	ECY 208
											32,7			
45	49	17,5	29	117	101	144	87	49	19	30,2	25,5	2,30	TU 45 TF	ECY 209
											32,7			
50	49	17,5	29	117	101	149	90	49	19	32,6	27	2,40	TU 50 TF	ECY 210
											32,7			
55	64	27	35	146	130	171	106	64	25	33,4	33,5	3,85	TU 55 TF	–



Pop Release[®] plummer block units

Pop Release plummer block units are ready-to-mount, sealed and greased bearing units. The units are an SKF development and consist of a one-piece cast iron plummer block housing, a spherical roller bearing based on series 222 bearings, two seals and a special adapter sleeve. They are filled with a lithium base grease having good rust inhibiting properties. Relubrication is possible via a grease nipple, if required. The units can compensate for errors of alignment up to 1,5° and can be operated in the temperature range -30 to +100 °C.

The special characteristics of SKF Pop Release units include very high radial and axial load carrying capacity, optimum sealing and simple mounting and maintenance.

The derived benefits are

- very quick mounting, both for the user and the machine builder;
- simplified stocking: units instead of several components;
- reduced lubricant consumption.

Benefits, therefore, which reduce costs.

Range

SKF Pop Release units are available in two variants: a non-locating unit (suffix L) and a locating unit (suffix F).

Dimensions

The dimensions of SKF Pop Release plummer block units are in accordance with ISO 113/II-1979, housing series “5”. The units are thus interchangeable with conventional plummer blocks of the same series.

Bearing internal clearance

SKF Pop Release units are supplied with pre-adjusted bearing clearance. When properly mounted on the shaft, therefore, the correct operational clearance will be obtained.

Shaft tolerances

SKF Pop Release units can be used on commercial drawn shafting. For normal operating conditions, shafts made to tolerance h10 are suitable. The cylindricity tolerance should be to IT7 according to ISO 1101.

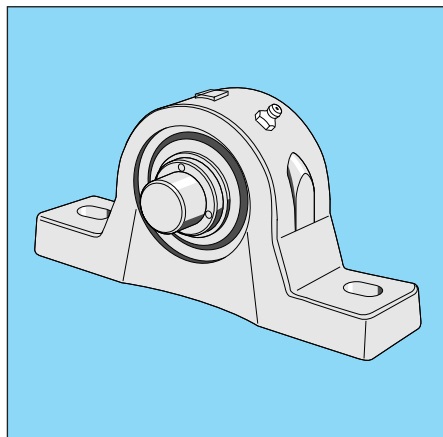

Pop Release plummer block units

d 35–75 mm

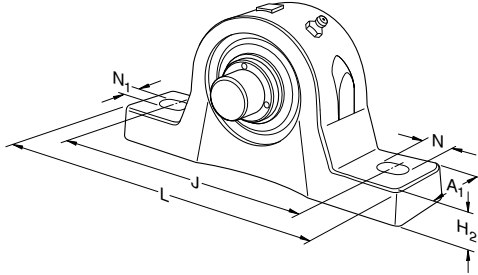
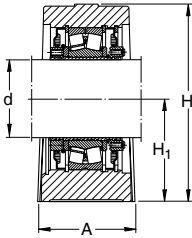

Dimensions										Bearing load rating dynamic C	Mass	Designations	
d	A	H	H ₁	H ₂	J	L	N	N ₁	Non-locating unit			Locating unit	
mm										kN	kg	–	
35	60	110	60	25	170	205	20	15	67,3	3,40	SYT 35 L	SYT 35 F	
40	60	114	60	25	170	205	20	15	89,7	3,50	SYT 40 L	SYT 40 F	
45	60	116	60	25	170	205	20	15	77,1	3,60	SYT 45 L	SYT 45 F	
50	70	129	70	28	210	255	24	18	84,5	4,80	SYT 50 L	SYT 50 F	
55	70	135	70	30	210	255	24	18	115	5,40	SYT 55 L	SYT 55 F	
60	80	150	80	30	230	275	24	18	140	7,00	SYT 60 L	SYT 60 F	
65	80	157	80	30	230	280	24	18	148	8,00	SYT 65 L	SYT 65 F	
70	90	177	95	32	260	315	28	22	179	10,6	SYT 70 L	SYT 70 F	
75	90	182	95	32	260	320	28	22	184	11,3	SYT 75 L	SYT 75 F	



SNH plummer block housings

SNH plummer block housings are an SKF development and are designed on the modular principle. They can be combined with a variety of seals. Together with a bearing they form economic, interchangeable bearing units, tailored to the needs of the application.

SNH housings have two elongated bolt holes in the base. The housings are horizontally split and faulty positioning of the cap on the base is prevented by dowel pins positioned off centre. The caps and bases must remain together as delivered.

SNH plummer block housings have a bearing seating designed for a non-locating bearing arrangement. A locating bearing arrangement is obtained by inserting one locating ring at each side of the bearing. The housings can accommodate self-aligning ball bearings or spherical roller bearings with either a cylindrical bore, or with a tapered bore and adapter sleeve.

SNH housings from SKF enable most plummer block applications in the shaft diameter range of 20 to 160 mm to be covered, and with only a small number of different housings.

Other benefits include

- the high product quality,
- the high strength,
- the large number of possible combinations, and
- the excellent price/performance ratio.

Range

SNH housings are produced in two designs: the standard design which cannot be relubricated unless opened, and the N design which can be relubricated. The N design has a threaded hole and grease nipple in the cap at the side of the bearing seating.

The larger sizes are also available in the extra high-strength SSNHD design. These housings are made of spheroidal graphite cast iron and are dimensionally the same as SNH housings except that the standard SSNHD design is without bolt holes in the base.

The SKF catalogue “Bearing housings” contains full details of the complete SKF housing range.

Dimensions

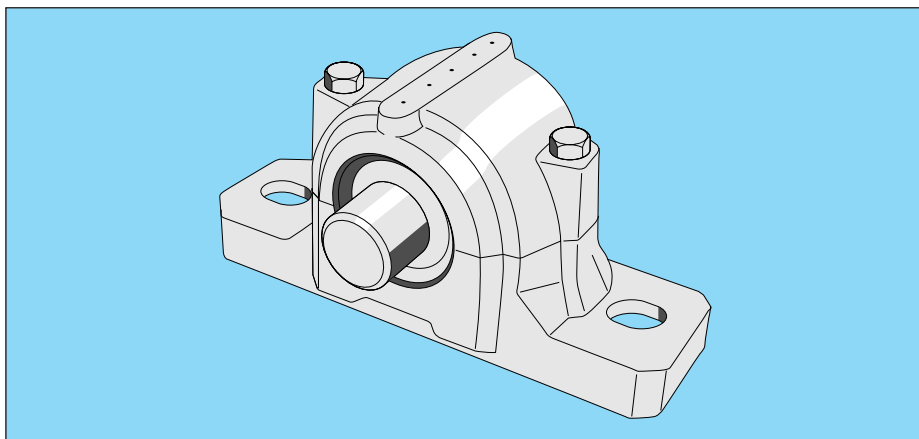

The dimensions of the SNH plummer block housings are in accordance with ISO 113/II-1979.

Materials

SNH plummer block housings are made of grey cast iron GG 20 and SSNHD housings of spheroidal graphite cast iron GGG 30.

Seals

One of the big advantages of SNH housings is that they can be fitted with different seals. The standard seals are

- double lip seals (TG),
- V-ring seals (TA), and
- felt seals (TC).

A special set, comprising a V-ring and splash plate covering a sector of more than 180°, is available for use with the N design housings which can be relubricated. The designation for this set is given in the table on page 153.

End covers

End covers of plastic are available for bearing arrangements at the end of a shaft. The cover is inserted in the seal groove.

Lubrication

SNH plummer block housings are designed for grease lubrication. However, oil lubrication can be used with the larger housings provided special seals are used and certain precautions taken.

How to order

Example: two SNH plummer block housings of size 512 with double lip seals to take spherical roller bearings 22212 EK on adapter sleeves H 312, one housing for a locating and one for a non-locating bearing arrangement, and one housing for a shaft end and one for a through shaft.

The order should read:

2 plummer block housings	SNH 512-610
2 seal sets	TSNA 512 G
1 end cover	ASNH 512-610
2 locating rings	FRB 10/110

The bearings (and adapter sleeves) must always be ordered separately.

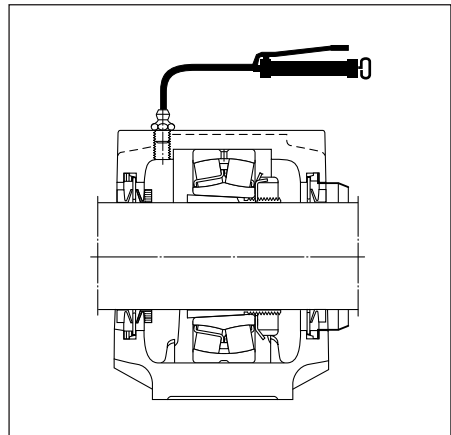

SNH plummer block housings for bearings with adapter sleeve

d_a 20–140 mm

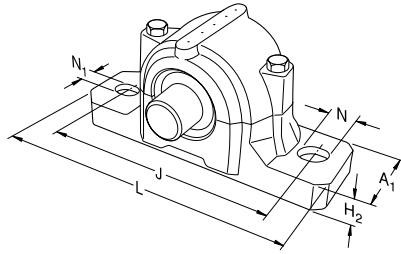
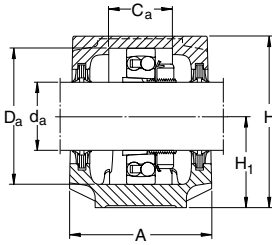

Dimensions

Mass

Designations for complete units

d_a	A	A ₁	C _a	D _a	H	H ₁	H ₂	J	L	N	N ₁	kg	Housing with double-lip seals	V-ring seals	felt seals
20	67	46	25	52	74	40	19	130	165	20	15	1,45	SNH 505 TG	SNH 505 TA	SNH 505 TC
	77	52	32	62	89	50	22	150	185	20	15	2,00	SNH 605 TG	SNH 605 TA	SNH 605 TC
25	77	52	32	62	89	50	22	150	185	20	15	2,00	SNH 506 TG	SNH 506 TA	SNH 506 TC
	82	52	34	62	93	50	22	150	185	20	15	2,20	SNH 606 TG	SNH 606 TA	SNH 606 TC
30	82	52	34	72	93	50	22	150	120	20	15	2,20	SNH 507 TG	SNH 507 TA	SNH 507 TC
	85	60	39	80	107	60	25	170	205	20	15	2,90	SNH 607 TG	SNH 607 TA	SNH 607 TC
35	85	60	39	80	107	60	25	170	205	20	15	2,90	SNH 508 TG	SNH 508 TA	SNH 508 TC
	90	60	41	90	113	60	25	170	205	20	15	3,20	SNH 608 TG	SNH 608 TA	SNH 608 TC
40	85	60	30	85	109	60	25	170	205	20	15	2,90	SNH 509 TG	SNH 509 TA	SNH 509 TC
	95	70	44	100	127	70	28	210	255	24	18	4,40	SNH 609 TG	SNH 609 TA	SNH 609 TC
45	90	60	41	90	113	60	25	170	205	20	15	3,20	SNH 510 TG	SNH 510 TA	SNH 510 TC
	105	70	48	110	133	70	30	210	255	24	18	5,10	SNH 610 TG	SNH 610 TA	SNH 610 TC
50	95	70	44	100	127	70	28	210	255	24	18	4,40	SNH 511 TG	SNH 511 TA	SNH 511 TC
	110	80	51	120	148	80	30	230	275	24	18	6,50	SNH 611 TG	SNH 611 TA	SNH 611 TC
55	105	70	48	110	133	70	30	210	255	24	18	5,10	SNH 512 TG	SNH 512 TA	SNH 512 TC
	115	80	56	130	154	80	30	230	280	24	18	7,00	SNH 612 TG	SNH 612 TA	SNH 612 TC
60	110	80	51	120	148	80	30	230	275	24	18	6,50	SNH 513 TG	SNH 513 TA	SNH 513 TC
	120	90	58	140	175	95	32	260	315	28	22	9,50	SNH 613 TG	SNH 613 TA	SNH 613 TC
65	115	80	56	130	154	80	30	230	280	24	18	7,00	SNH 515 TG	SNH 515 TA	SNH 515 TC
	140	100	65	160	193	100	35	290	345	28	22	12,5	SNH 615 TG	SNH 615 TA	SNH 615 TC
70	120	90	58	140	175	95	32	260	315	28	22	9,50	SNH 516 TG	SNH 516 TA	SNH 516 TC
	145	100	68	170	210	112	35	290	345	28	22	13,7	SNH 616 TG	SNH 616 TA	SNH 616 TC
75	125	90	61	150	183	95	32	260	320	28	22	10,0	SNH 517 TG	SNH 517 TA	SNH 517 TC
	160	100	70	180	215	112	40	320	380	32	26	17,6	SNH 617 TG	SNH 617 TA	SNH 617 TC
80	140	100	65	160	193	100	35	290	345	28	22	12,5	SNH 518 TG	SNH 518 TA	SNH 518 TC
85	145	100	68	170	210	112	35	290	345	28	22	13,7	SNH 519 TG	SNH 519 TA	SNH 519 TC
	175	120	80	200	239	125	40	350	410	32	26	22,0	SNH 619 TG	SNH 619 TA	SNH 619 TC
90	160	110	70	180	215	112	40	320	380	32	26	17,6	SNH 520 TG	SNH 520 TA	SNH 520 TC
	185	120	80	215	271	140	45	350	410	32	26	26,2	SNH 620 TG	SNH 620 TA	SNH 620 TC
100	175	120	80	200	239	125	45	350	410	32	26	22,0	SNH 522 TG	SNH 522 TA	SNH 522 TC
110	185	120	86	215	271	140	45	350	410	32	26	26,2	SNH 524 TG	SNH 524 TA	SNH 524 TC
115	190	130	90	230	290	150	50	380	445	35	28	33,0	SNH 526 TG	SNH 526 TA	SNH 526 TC
125	205	150	98	250	302	150	50	420	500	42	35	40,0	SNH 528 TG	SNH 528 TA	SNH 528 TC
135	220	160	106	270	323	160	50	450	530	42	35	49,0	SNH 530 TG	SNH 530 TA	SNH 530 TC
140	235	160	114	290	344	170	50	470	550	42	35	55,0	SNH 532 TG	SNH 532 TA	SNH 532 TC

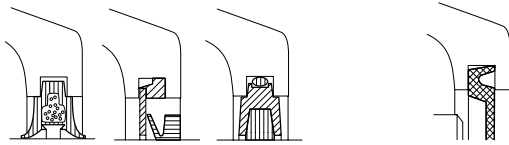

Designations for components

Housing without seals made of grey cast iron		spheroidal graphite cast iron	with grease nipple	2 double-lip seals	2 V-ring seals	2 felt seals	Accessory set for housings which can be relubricated	End cover for housings at shaft ends
SNH 505	–	SNH 505 N	TSNA 505 G	TSNA 505 A	TSNA 505 C	ASNA 505 V	ASNH 505	
SNH 506-605	–	SNH 506-605 N	TSNA 605 G	TSNA 605 A	TSNA 605 C	–	ASNH 506-605	
SNH 506-605	–	SNH 506-605 N	TSNA 506 G	TSNA 506 A	TSNA 506 C	–	ASNH 506-605	
SNH 507-606	–	SNH 507-606 N	TSNA 606 G	TSNA 606 A	TSNA 606 C	ASNA 606 V	ASNH 507-606	
SNH 507-606	–	SNH 507-606 N	TSNA 507 G	TSNA 507 A	TSNA 507 C	ASNA 507 V	ASNH 507-606	
SNH 508-607	–	SNH 508-607 N	TSNA 607 G	TSNA 607 A	TSNA 607 C	ASNA 607 V	ASNH 508-607	
SNH 508-607	–	SNH 508-607 N	TSNA 508 G	TSNA 508 A	TSNA 508 C	ASNA 508 V	ASNH 508-607	
SNH 510-608	–	SNH 510-608 N	TSNA 608 G	TSNA 608 A	TSNA 608 C	ASNA 608 V	ASNH 510-608	
SNH 509	–	SNH 509 N	TSNA 509 G	TSNA 509 A	TSNA 509 C	ASNA 509 V	ASNH 509	
SNH 511-609	SSNHD 511-609	SNH 511-609 N	TSNA 609 G	TSNA 609 A	TSNA 609 C	ASNA 609 V	ASNH 511-609	
SNH 510-608	–	SNH 510-608 N	TSNA 510 G	TSNA 510 A	TSNA 510 C	ASNA 510 V	ASNH 510-608	
SNH 512-610	SSNHD 512-610	SNH 512-610 N	TSNA 610 G	TSNA 610 A	TSNA 610 C	ASNA 610 V	ASNH 512-610	
SNH 511-609	SSNHD 511-609	SNH 511-609 N	TSNA 511 G	TSNA 511 A	TSNA 511 C	ASNA 511 V	ASNH 511-609	
SNH 513-611	SSNHD 513-611	SNH 513-611 N	TSNA 611 G	TSNA 611 A	TSNA 611 C	ASNA 611 V	ASNH 513-611	
SNH 512-610	SSNHD 512-610	SNH 512-610 N	TSNA 512 G	TSNA 512 A	TSNA 512 C	ASNA 512 V	ASNH 512-610	
SNH 515-612	SSNHD 515-612	SNH 515-612 N	TSNA 612 G	TSNA 612 A	TSNA 612 C	ASNA 612 V	ASNH 515-612	
SNH 513-611	SSNHD 513-611	SNH 513-611 N	TSNA 513 G	TSNA 513 A	TSNA 513 C	ASNA 513 V	ASNH 513-611	
SNH 516-613	SSNHD 516-613	SNH 516-613 N	TSNA 613 G	TSNA 613 A	TSNA 613 C	ASNA 613 V	ASNH 516-613	
SNH 515-612	SSNHD 515-612	SNH 515-612 N	TSNA 515 G	TSNA 515 A	TSNA 515 C	ASNA 515 V	ASNH 515-612	
SNH 518-615	SSNHD 518-615	SNH 518-615 N	TSNA 615 G	TSNA 615 A	TSNA 615 C	ASNA 615 V	ASNH 518-615	
SNH 516-613	SSNHD 516-613	SNH 516-613 N	TSNA 516 G	TSNA 516 A	TSNA 516 C	ASNA 516 V	ASNH 516-613	
SNH 519-616	SSNHD 519-616	SNH 519-616 N	TSNA 616 G	TSNA 616 A	TSNA 616 C	ASNA 616 V	ASNH 519-616	
SNH 517	SSNHD 517	SNH 517 N	TSNA 517 G	TSNA 517 A	TSNA 517 C	ASNA 517 V	ASNH 517	
SNH 520-617	SSNHD 520-617	SNH 520-617 N	TSNA 617 G	TSNA 617 A	TSNA 617 C	–	ASNH 520-617	
SNH 518-615	SSNHD 518-615	SNH 518-615 N	TSNA 518 G	TSNA 518 A	TSNA 518 C	ASNA 518 V	ASNH 518-615	
SNH 519-616	SSNHD 519-616	SNH 519-616 N	TSNA 519 G	TSNA 519 A	TSNA 519 C	ASNA 519 V	ASNH 519-616	
SNH 522-619	SSNHD 522-619	SNH 522-619 N	TSNA 619 G	TSNA 619 A	TSNA 619 C	–	ASNH 522-619	
SNH 520-617	SSNHD 520-617	SNH 520-617 N	TSNA 520 G	TSNA 520 A	TSNA 520 C	ASNA 520 V	ASNH 520-617	
SNH 524-620	SSNHD 524-620	SNH 524-620 N	TSNA 620 G	TSNA 620 A	TSNA 620 C	ASNA 620 V	ASNH 524-620	
SNH 522-619	SSNHD 522-619	SNH 522-619 N	TSNA 522 G	TSNA 522 A	TSNA 522 C	ASNA 522 V	ASNH 522-619	
SNH 524-620	SSNHD 524-620	SNH 524-620 N	TSNA 624 G	TSNA 624 A	TSNA 624 C	ASNA 624 V	ASNH 524-620	
SNH 526	SSNHD 526	SNH 526 N	TSNA 526 G	TSNA 526 A	TSNA 526 C	ASNA 526 V	ASNH 526	
SNH 528	SSNHD 528	SNH 528 N	TSNA 528 G	TSNA 528 A	TSNA 528 C	ASNA 528 V	ASNH 528	
SNH 530	SSNHD 530	SNH 530 N	TSNA 530 G	TSNA 530 A	TSNA 530 C	ASNA 530 V	ASNH 530	
SNH 532	SSNHD 532	SNH 532 N	TSNA 532 G	TSNA 532 A	TSNA 532 C	ASNA 532 V	ASNH 532	



SNH plummer block housings for bearings with cylindrical bore
d_a 25–160 mm

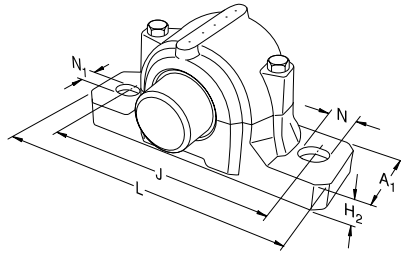
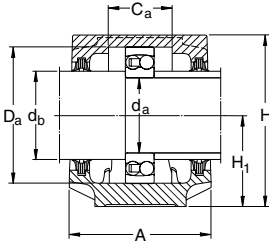

Dimensions

Mass Designations for complete units

d _a	d _b	A	A ₁	C _a	D _a	H	H ₁	H ₂	J	L	N	N ₁	Mass	Designations for complete units	Designations for complete units	Designations for complete units	
														Housings with double-lip seals	V-ring seals	felt seals	
mm														kg	–		
25	30	67	46	25	52	74	40	19	130	165	20	15	1,40	SNH 205 TG	–	SNH 205 TC	
	30	77	52	32	62	89	50	22	150	185	20	15	1,90	SNH 305 TG	–	–	
30	35	77	52	32	62	89	50	22	150	185	20	15	1,90	SNH 206 TG	SNH 306 TA	SNH 206 TC	
	35	82	52	34	72	93	50	22	150	185	20	15	2,20	SNH 306 TG	SNH 306 TA	–	
35	45	82	52	34	72	93	50	22	150	185	20	15	2,10	SNH 207 TG	SNH 207 TA	SNH 207 TC	
	45	85	60	39	80	107	60	25	170	205	20	15	2,90	SNH 307 TG	SNH 307 TA	–	
40	50	85	60	39	80	107	60	25	170	205	20	15	2,75	SNH 208 TG	SNH 208 TA	SNH 208 TC	
	50	90	60	41	90	113	60	25	170	205	20	15	3,20	SNH 308 TG	SNH 308 TA	–	
45	55	85	60	30	85	109	60	25	170	205	20	15	2,75	SNH 209 TG	SNH 209 TA	SNH 209 TC	
	55	95	70	44	100	127	70	28	210	255	20	15	4,40	SNH 309 TG	SNH 309 TA	–	
50	60	90	60	41	90	113	60	25	170	205	20	15	3,00	SNH 210 TG	SNH 210 TA	SNH 210 TC	
	60	105	70	48	110	133	70	30	210	255	24	18	5,10	SNH 310 TG	SNH 310 TA	–	
55	65	95	70	44	100	127	70	28	210	255	24	18	4,20	SNH 211 TG	SNH 211 TA	SNH 211 TC	
	65	110	80	51	120	148	80	30	230	275	24	18	6,50	SNH 311 TG	SNH 311 TA	–	
60	70	105	70	48	110	133	70	30	210	255	24	18	4,75	SNH 212 TG	SNH 212 TA	SNH 212 TC	
	70	115	80	56	130	154	80	30	230	280	24	18	7,00	SNH 312 TG	SNH 312 TA	–	
65	75	110	80	51	120	148	80	30	230	275	24	18	6,10	SNH 213 TG	SNH 213 TA	SNH 213 TC	
	75	120	90	58	140	175	95	32	260	315	28	22	9,50	SNH 313 TG	SNH 313 TA	–	
70	80	125	90	61	150	183	95	32	260	320	28	22	10,0	SNH 314 TG	SNH 314 TA	–	
75	85	115	80	56	130	154	80	30	230	280	24	18	6,60	SNH 215 TG	SNH 215 TA	SNH 215 TC	
	85	140	100	65	160	193	100	35	290	345	28	22	12,5	SNH 315 TG	SNH 315 TA	–	
80	90	120	90	58	140	175	95	32	260	315	28	22	9,00	SNH 216 TG	SNH 216 TA	SNH 216 TC	
	90	145	100	68	170	210	112	35	290	345	28	22	13,7	SNH 316 TG	SNH 316 TA	–	
85	95	125	90	61	150	183	95	32	260	320	28	22	9,50	SNH 217 TG	SNH 217 TA	SNH 217 TC	
	95	160	110	70	180	215	112	40	320	380	32	26	17,6	SNH 317 TG	SNH 317 TA	–	
90	100	140	100	65	160	193	100	35	290	345	28	22	11,8	SNH 218 TG	SNH 218 TA	SNH 218 TC	
100	115	160	110	70	180	215	112	40	320	380	32	26	17,6	SNH 220 TG	SNH 220TA	–	
110	125	175	120	80	200	239	125	45	350	410	32	26	22,0	SNH 222 TG	SNH 222 TA	–	
120	135	185	120	86	215	271	140	45	350	410	32	26	26,2	SNH 224 TG	SNH 224 TA	–	
130	145	190	130	90	230	290	150	50	380	445	45	28	33,0	SNH 226 TG	SNH 226 TA	–	
140	155	205	150	98	250	302	150	50	420	500	42	35	40,0	SNH 228 TG	SNH 228 TA	–	
150	165	220	160	106	270	323	160	60	450	530	42	35	49,0	SNH 230 TG	SNH 230 TA	–	
160	175	235	160	114	290	344	170	60	470	550	42	35	55,0	SNH 232 TG	SNH 232 TA	–	

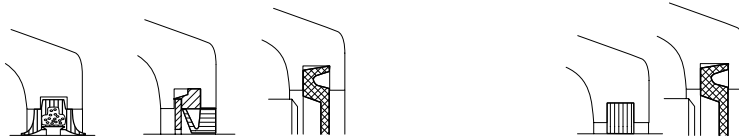

Designations for components
Housings with double-lip seals and V-ring seals

Housing with felt seals

Housing without seals	2 double-lip seals	2 V-ring seals	End cover for housings at shaft ends	Housing	Felt strips (No. and designation)	End cover for housings at shaft ends
SNH 205 SNH 506-605	TSNA 305 G TSNA 507 G	–	ASNH 506-605 ASNH 506-605	SNH 505 –	2 FS 170 –	ASNH 505 –
SNH 206 SNH 507-606	TSNA 306 G TSNA 306 G	TSNA 306 A TSNA 306 A	ASNH 507-606 ASNH 507-606	SNH 506-605 –	2 FS 170 –	ASNH 506-609 –
SNH 207 SNH 208	TSNA 307 G TSNA 510 G	TSNA 307 A TSNA 510 A	ASNH 508-606 ASNH 510-608	SNH 507-606 –	2 FS 170 –	ASNH 507-606 –
SNH 208 SNH 510-608	TSNA 308 G TSNA 308 G	TSNA 308 A TSNA 308 A	ASNH 510-608 ASNH 510-608	SNH 508-607 –	4 FS 170 –	ASNH 508-607 –
SNH 209 SNH 511-609	TSNA 309 G TSNA 309 G	TSNA 309 A TSNA 309 A	ASNH 511-609 ASNH 511-609	SNH 509 –	4 FS 170 –	ASNH 509 –
SNH 210 SNH 512-610	TSNA 310 G TSNA 310 G	TSNA 310 A TSNA 310 A	ASNH 512-610 ASNH 512-610	SNH 510-608 –	4 FS 170 –	ASNH 510-608 –
SNH 211 SNH 513-611	TSNA 311 G TSNA 311 G	TSNA 311 A TSNA 311 A	ASNH 513-611 ASNH 513-611	SNH 511-609 –	4 FS 170 –	ASNH 511-609 –
SNH 212 SNH 515-612	TSNA 312 G TSNA 315 G	TSNA 312 A TSNA 312 A	ASNH 515-612 ASNH 515-612	SNH 512-610 –	4 FS 170 –	ASNH 512-610 –
SNH 213 SNH 516-613	TSNA 313 G TSNA 313 G	TSNA 313 A TSNA 313 A	ASNH 516-613 ASNH 516-613	SNH 513-611 –	4 FS 170 –	ASNH 513-611 –
SNH 517	TSNA 314 G	TSNA 314 A	ASNH 517	–	–	–
SNH 215 SNH 518-615	TSNA 315 G TSNA 315 G	TSNA 315 A TSNA 315 A	ASNH 518-615 ASNH 518-615	SNH 515-612 –	4 FS 170 –	ASNH 515-612 –
SNH 216 SNH 519-616	TSNA 216 G TSNA 316 G	TSNA 216 A TSNA 316 A	ASNH 216 ASNH 519-616	SNH 516-613 –	4 FS 170 –	ASNH 516-613 –
SNH 217 SNH 520-617	TSNA 217 G TSNA 317 G	TSNA 217 A TSNA 317 A	ASNH 217 ASNH 520-617	SNH 517 –	4 FS 170 –	ASNH 517 –
SNH 218	TSNA 218 G	TSNA 218 A	ASNH 218	SNH 518-615	4 FS 170	ASNH 518-615
SNH 520-617	TSNA 220 G	TSNA 220 A	ASNH 520-617	–	–	–
SNH 522-619	TSNA 222 G	TSNA 222 A	ASNH 522-619	–	–	–
SNH 524-620	TSNA 224 G	TSNA 224 A	ASNH 524-620	–	–	–
SNH 526	TSNA 226 G	TSNA 226 A	ASNH 526	–	–	–
SNH 528	TSNA 228 G	TSNA 228 A	ASNH 528	–	–	–
SNH 530	TSNA 230 G	TSNA 230 A	ASNH 530	–	–	–
SNH 532	TSNA 232 G	TSNA 232 A	ASNH 532	–	–	–



SNH plummer block housings, series 5 and 6, and appropriate bearings with adapter sleeve

Housing Designation	Shaft diameter d_a	Appropriate self-aligning ball bearings and spherical roller bearings		
		Bearing designation + locating ring designation (2 locating rings are required for a locating arrangement)		
— mm —				
SNH 505 ..	20	1205 EK + FRB 5/52	2205 EK + FRB 3.5/52	22205 CCK + FRB 3.5/52
SNH 506 ..	25	1206 EK + FRB 8/62	2206 EK + FRB 6/62	22206 CCK + FRB 6/62
SNH 507 ..	30	1207 EK + FRB 8.5/72	2207 EK + FRB 5.5/72	22207 CCK + FRB 5.5/72
SNH 508 ..	35	1208 EK + FRB 10.5/80	2208 EK + FRB 8/80	22208 EK + FRB 8/80
SNH 509 ..	40	1209 EK + FRB 5.5/85	2209 EK + FRB 3.5/85	22209 CCK + FRB 3.5/85
SNH 510 ..	45	1210 EK + FRB 10.5/90	2210 EK + FRB 9/90	22210 EK + FRB 9/90
SNH 511 ..	50	1211 EK + FRB 11.5/100	2211 EK + FRB 9.5/100	22211 EK + FRB 9.5/100
SNH 512 ..	55	1212 EK + FRB 13/110	2212 EK + FRB 10/110	22212 EK + FRB 10/110
SNH 513 ..	60	1213 EK + FRB 14/120	2213 EK + FRB 10/120	22213 CCK + FRB 10/120
SNH 515 ..	65	1215 K + FRB 15.5/130	2215 EK + FRB 12.5/130	22215 EK + FRB 12.5/130
SNH 516 ..	70	1216 K + FRB 16/140	2216 EK + FRB 12.5/140	22216 EK + FRB 12.5/140
SNH 517 ..	75	1217 K + FRB 16.5/150	2217 K + FRB 12.5/150	22217 EK + FRB 12.5/150
SNH 518 ..	80	1218 K + FRB 17.5/160	2218 K + FRB 12.5/160	22218 EK + FRB 12.5/160
SNH 520 ..	90	1220 K + FRB 18/180	2220 K + FRB 12/180	22220 EK + FRB 12/180
SNH 522 ..	100	1222 K + FRB 21/200	2222 EK + FRB 13.5/200	22222 EK + FRB 13.5/200
SNH 524 ..	110	22224 EK + FRB 14/215	23224 CCK/W33 + FRB 5/215	
SNH 526 ..	115	22226 EK + FRB 13/230	23226 CCK/W33 + FRB 5/230	
SNH 528 ..	125	22228 CCK/W33 + FRB 15/250	23228 CCK/W33 + FRB 5/250	
SNH 530 ..	135	22230 CCK/W33 + FRB 16.5/270	23230 CCK/W33 + FRB 5/270	
SNH 532 ..	140	22232 CCK/W33 + FRB 17/290	23232 CCK/W33 + FRB 5/290	
SNH 605 ..	20	1305 EK + FRB 7.5/62	2305 K + FRB 4/62	
SNH 606 ..	25	1306 EK + FRB 7.5/72	2306 K + FRB 3.5/72	
SNH 607 ..	30	1307 EK + FRB 9/80	2307 EK + FRB 4/80	
SNH 608 ..	35	1308 EK + FRB 9/90	2308 EK + FRB 4/90	
SNH 609 ..	40	1309 EK + FRB 9.5/100 22309 CCK + FRB 4/100	2309 EK + FRB 4/100	21309 EK + FRB 9.5/100
SNH 610 ..	45	1310 EK + FRB 10.5/110 22310 EK + FRB 4/110	2310 K + FRB 4/110	21310 EK + FRB 10.5/110
SNH 611 ..	50	1311 EK + FRB 11/120 22311 EK + FRB 4/120	2311 K + FRB 4/120	21311 EK + FRB 11/120
SNH 612 ..	55	1312 EK + FRB 12.5/130 22312 EK + FRB 5/130	2312 K + FRB 5/130	21312 EK + FRB 12.5/130
SNH 613 ..	60	1313 EK + FRB 12.5/140 22313 EK + FRB 5/140	2313 K + FRB 5/140	21313 EK + FRB 12.5/140
SNH 615 ..	65	1315 K + FRB 14/160 22315 EK + FRB 5/160	2315 K + FRB 5/160	21315 EK + FRB 14/160
SNH 616 ..	70	1316 K + FRB 14.5/170 22316 EK + FRB 5/170	2316 K + FRB 5/170	21316 EK + FRB 14.5/170
SNH 617 ..	75	1317 K + FRB 14.5/180 22317 EK + FRB 5/180	2317 K + FRB 5/180	21317 EK + FRB 14.5/180
SNH 619 ..	85	22319 EK + FRB 6/200		
SNH 620 ..	90	1320 K + FRB 19.5/215	21320 EK + FRB 19.5/215	22320 EK + FRB 6.5/215

SNH plummer block housings, series 2 and 3, and appropriate bearings with cylindrical bore

Housing Designation	Shaft diameter d_a	Appropriate self-aligning ball bearings and spherical roller bearings		
		Bearing designation + locating ring designation (2 locating rings are required for a locating arrangement)		
— mm —				
SNH 205 ..	25	1205 E + FRB 5/52	2205 E + FRB 3.5/52	22205 CC + FRB 3.5/52
SNH 206 ..	30	1206 E + FRB 8/62	2206 E + FRB 6/62	22206 CC + FRB 6/62
SNH 207 ..	35	1207 E + FRB 8.5/72	2207 E + FRB 5.5/72	22207 CC + FRB 5.5/72
SNH 208 ..	40	1208 E + FRB 10.5/80	2208 E + FRB 8/80	22208 E + FRB 8/80
SNH 209 ..	45	1209 E + FRB 5.5/85	2209 E + FRB 3.5/85	22209 CC + FRB 3.5/85
SNH 210 ..	50	1210 E + FRB 10.5/90	2210 E + FRB 9/90	22210 E + FRB 9/90
SNH 211 ..	55	1211 E + FRB 11.5/100	2211 E + FRB 9.5/100	22211 E + FRB 9.5/100
SNH 212 ..	60	1212 E + FRB 13/110	2212 E + FRB 10/110	22212 E + FRB 10/110
SNH 213 ..	65	1213 E + FRB 14/120	2213 E + FRB 10/120	22213 CC + FRB 10/120
SNH 215 ..	75	1215 + FRB 15.5/130	2215 E + FRB 12.5/130	22215 E + FRB 12.5/130
SNH 216 ..	80	1216 + FRB 16/140	2216 E + FRB 12.5/140	22216 E + FRB 12.5/140
SNH 217 ..	85	1217 + FRB 16.5/150	2217 + FRB 12.5/150	22217 E + FRB 12.5/150
SNH 218 ..	90	1218 + FRB 17.5/160	2218 + FRB 12.5/160	22218 E + FRB 12.5/160
SNH 220 ..	100	23218 CC + FRB 6.25/160 1220 + FRB 18/180	2220 + FRB 12/180	22220 E + FRB 12/180
SNH 222 ..	110	23220 CC/W33 + FRB 4.85/180 1222 + FRB 21/200 23222 CC/W33 + FRB 5.1/200	2222 E + FRB 13.5/200	22222 E + FRB 13.5/200
SNH 224 ..	120	22224 E + FRB 14/215	23224 CC/W33 + FRB 5/215	
SNH 226 ..	130	22226 E + FRB 13/230	23226 CC/W33 + FRB 5/230	
SNH 228 ..	140	22228 CC/W33 + FRB 15/250	23228 CC/W33 + FRB 5/250	
SNH 230 ..	150	22230 CC/W33 + FRB 16.5/270	23230 CC/W33 + FRB 5/270	
SNH 232 ..	160	22232 CC/W33 + FRB 17/290	23232 CC/W33 + FRB 5/290	
SNH 305 ..	25	1305 E + FRB 7.5/62	2305 + FRB 4/62	21305 CC + FRB 7.5/62
SNH 306 ..	30	1306 E + FRB 7.5/72	2306 + FRB 3.5/72	21306 CC + FRB 7.5/72
SNH 307 ..	35	1307 E + FRB 9/80	2307 E + FRB 4/80	21307 CC + FRB 9/80
SNH 308 ..	40	1308 E + FRB 9/90 22308 E + FRB 4/90	2308 E + FRB 4/90	21308 CC + FRB 9/90
SNH 309 ..	45	1309 E + FRB 9.5/100 22309 CC + FRB 4/100	2309 E + FRB 4/100	21309 E + FRB 9/100
SNH 310 ..	50	1310 E + FRB 10.5/110 22310 E + FRB 4/110	2310 + FRB 4/110	21310 E + FRB 10.5/100
SNH 311 ..	55	1311 E + FRB 11/120 22311 E + FRB 4/120	2311 + FRB 4/120	21311 E + FRB 11/120
SNH 312 ..	60	1312 E + FRB 12.5/130 22312 E + FRB 5/130	2312 + FRB 5/130	21312 E + FRB 12.5/130
SNH 313 ..	65	1313 E + FRB 12.5/140 22313 E + FRB 5/140	2313 + FRB 5/140	21313 E + FRB 12.5/140
SNH 314 ..	70	1314 E + FRB 13/150 22314 E + FRB 5/150	2314 + FRB 5/150	21314 E + FRB 13/150
SNH 315 ..	75	1315 + FRB 14/160 22315 E + FRB 5/160	2315 + FRB 5/160	21315 E + FRB 14/160
SNH 316 ..	80	1316 + FRB 14.5/170 22316 E + FRB 5/170	2316 + FRB 5/170	21316 E + FRB 14.5/170
SNH 317 ..	85	1317 + FRB 14.5/180 22317 E + FRB 5/180	2317 + FRB 5/180	21317 E + FRB 14.5/180

Adapter and withdrawal sleeves

Adapter and withdrawal sleeves are used to locate bearings having a tapered bore on a cylindrical shaft. They simplify mounting and dismounting of the bearing, and in many cases, bearing arrangement design.

As the adapter and withdrawal sleeves adapt themselves to the shaft diameter, relatively large shaft tolerances are permitted. However, the form tolerance should be tighter as the accuracy of form influences the running accuracy of the bearing. Generally, shaft seatings machined to tolerance h9 are adequate, but the cylindricity tolerance should be to IT5.

SKF adapter and withdrawal sleeves have

- high quality material,
- accurate form, and
- an excellent price/performance ratio.

Range

The SKF popular range of adapter and withdrawal sleeves comprises all the popular sizes and series.

Adapter sleeves

SKF adapter sleeves are supplied complete with lock nut and locking device. The adapter sleeves are slotted and have an external taper of 1:12. Up to and including size 30 they are black oxidised; other sizes are bright and oiled.

To enable the oil injection method to be used, SKF adapter sleeves having a bore diameter of 200 mm and above have an oil supply duct at the threaded side and an oil distribution groove in the outside diameter. These sleeves are designated OH .. H.

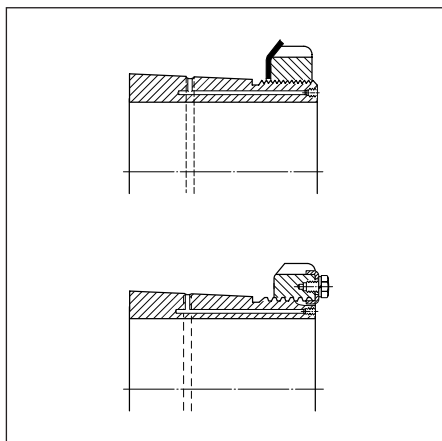
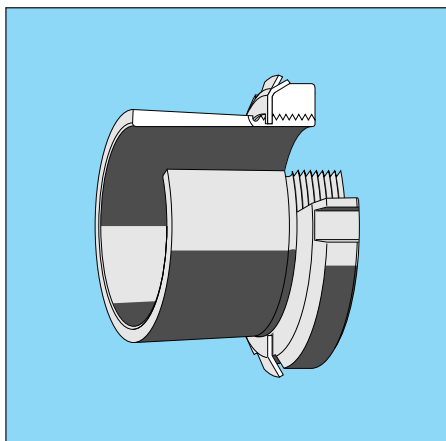

Withdrawal sleeves

SKF withdrawal sleeves are treated with a corrosion inhibitor. They are slotted and have an external taper of 1:12, except for sleeves of series AH 240 and AH 241, which have an external taper of 1:30 and are designed for use with the wide spherical roller bearings of series 240 K30 and 241 K30.

SKF withdrawal sleeves carrying the suffix G have a thread diameter which is smaller than standard.

To enable the oil injection method to be used, SKF withdrawal sleeves having a bore diameter of 200 mm and above are supplied as standard in the AOH design. These sleeves have two oil supply ducts at the threaded side as well as distribution grooves in the circumferential and axial directions. These grooves are in the outside surface as well as in the sleeve bore.

Dimensions

The dimensions of the adapter sleeves are in accordance with ISO 113/1-1979.

The withdrawal sleeves having a 1:12 external taper follow the dimensions specified in ISO 113/1-1979.

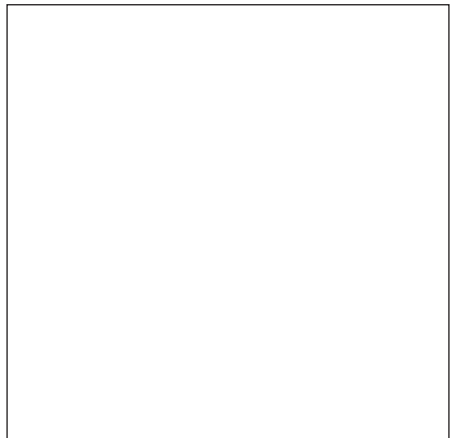
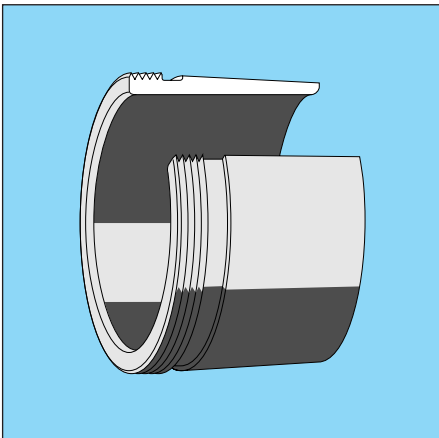

Adapter sleeves

d_1 20–80 mm

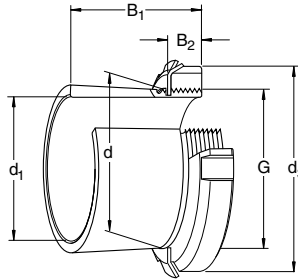

Dimensions						Mass	Designation Adapter sleeve complete	Appropriate self-aligning ball bearings and spherical roller bearings			
d_1	d	d_3	B_1	B_2	G						
mm						kg	–	–			
20	25	38	26	8	M 25×1,5	0,064	H 205	1205 EK			
		38	29	8	M 25×1,5	0,071	H 305	1305 EK	2205 EK	22205 CCK	
25	30	45	27	8	M 30×1,5	0,086	H 206	1206 EK			
		45	31	8	M 30×1,5	0,095	H 306	1306 EK	2206 EK	22206 CCK	
		45	38	8	M 30×1,5	0,11	H 2306	2306 EK			
30	35	52	29	9	M 35×1,5	0,12	H 207	1207 EK			
		52	35	9	M 35×1,5	0,14	H 307	1307 EK	2207 EK	22207 CCK	
		52	43	9	M 35×1,5	0,16	H 2307	2307 EK			
35	40	58	31	10	M 40×1,5	0,16	H 208	1208 EK			
		58	36	10	M 40×1,5	0,17	H 308	1308 EK	2208 EK	21308 CCK 22208 K	
		58	46	10	M 40×1,5	0,22	H 2308	2308 EK	22308 EK		
40	45	65	33	11	M 45×1,5	0,21	H 209	1209 EK			
		65	39	11	M 45×1,5	0,23	H 309	1309 EK	2209 EK	21309 EK 22209 CCK	
		65	50	11	M 45×1,5	0,27	H 2309	2309 EK	22309 CCK		
45	50	70	35	12	M 50×1,5	0,24	H 210	1210 EK			
		70	42	12	M 50×1,5	0,27	H 310	1310 EK	2210 EK	21310 EK 22210 EK	
		70	55	12	M 50×1,5	0,34	H 2310	2310 EK	22310 EK		
50	55	75	37	12,5	M 55×2	0,28	H 211	1211 EK			
		75	45	12,5	M 55×2	0,32	H 311	1311 EK	2211 EK	21311 EK 22211 EK	
		75	59	12,5	M 55×2	0,39	H 2311	2311 EK	22311 EK		
55	60	80	38	13	M 60×2	0,31	H 212	1212 EK			
		80	47	13	M 60×2	0,36	H 312	1312 EK	2212 EK	21312 EK 22212 EK	
		80	62	13	M 60×2	0,45	H 2312	2312 EK	22312 EK		
60	65	85	40	14	M 65×2	0,36	H 213	1213 EK			
		85	50	14	M 65×2	0,42	H 313	1313 EK	2213 EK	21313 EK 22213 CCK	
		85	65	14	M 65×2	0,52	H 2313	2313 K	22313 EK		
60	70	92	52	14	M 70×2	0,67	H 314	1214 K	21314 EK	22214 EK	
		92	68	14	M 70×2	0,88	H 2314	22314 EK			
65	75	98	43	15	M 75×2	0,66	H 215	1215 K			
		98	55	15	M 75×2	0,78	H 315	1315 K	2215 EK	21315 EK 22215 EK	
		98	73	15	M 75×2	1,10	H 2315	2315 K	22315 EK		
70	80	105	46	17	M 80×2	0,81	H 216	1216 K			
		105	59	17	M 80×2	0,95	H 316	1316 K	2216 EK	21316 EK 22216 EK	
		105	78	17	M 80×2	1,20	H 2316	2316 K	22316 EK		
75	85	110	50	18	M 85×2	0,94	H 217	1217 K			
		110	63	18	M 85×2	1,10	H 317	1317 K	2217 K	21317 EK 22217 EK	
		110	82	18	M 85×2	1,35	H 2317	2317 KM	22317 EK		
80	90	120	52	18	M 90×2	1,10	H 218	1218 K			
		120	65	18	M 90×2	1,30	H 318	1318 K	2218 K	21318 EK 22218 EK	
		120	86	18	M 90×2	1,60	H 2318	2318 KM	22318 EK	23218 CCK	

Adapter sleeves

d₁ 85–280 mm

Dimensions						Mass	Designation Adapter sleeve complete	Appropriate self-aligning ball bearings and sperical roller bearings	
d ₁	d	d ₃	B ₁	B ₂	G				
mm						kg	–	–	
85	95	125	55	19	M 95×2	1,25	H 219	1219 K	
		125	68	19	M 95×2	1,40	H 319	22219 EK	
		125	90	19	M 95×2	1,80	H 2319	22319 EK	
90	100	130	58	20	M 100×2	1,40	H 220	1220 K	
		130	71	20	M 100×2	1,60	H 320	1320 K	2220 KM
		130	97	20	M 100×2	2,00	H 2320	21320 EK 22320 EK	22220 EK 22320 CCK/W33
100	110	145	63	21	M 110×2	1,80	H 222	1222 K	
		145	77	21	M 110×2	2,05	H 322	1322 KM	2222 KM
		145	105	21	M 110×2	2,75	H 2322	2222 EK 22322 EK	23222 CCK/W33
110	120	145	72	22	M 120×2	1,80	H 3024	23024 CCK/W33	
		155	88	22	M 120×2	2,50	H 3124	23124 CCK/W33	22224 EK
		155	112	22	M 120×2	3,00	H 2324	23224 CCK/W33	22324 CCK/W33
115	130	155	80	23	M 130×2	2,80	H 3026	23026 CCK/W33	
		165	92	23	M 130×2	3,45	H 3126	23126 CCK/W33	22226 EK
		165	121	23	M 130×2	4,45	H 2326	23226 CCK/W33	22326 CCK/W33
125	140	165	82	24	M 140×2	3,05	H 3028	23028 CCK/W33	
		180	97	24	M 140×2	4,10	H 3128	23128 CCK/W33	22228 CCK/W33
		180	131	24	M 140×2	5,40	H 2328	23228 CCK/W33	22328 CCK/W33
135	150	180	87	26	M 150×2	3,75	H 3030	23030 CCK/W33	
		195	111	26	M 150×2	5,25	H 3130	23130 CCK/W33	22230 CCK/W33
		195	139	26	M 150×2	6,40	H 2330	23230 CCK/W33	22330 CCK/W33
140	160	190	93	27,5	M 160×3	5,10	H 3032	23032 CCK/W33	
		210	119	28	M 160×3	7,25	H 3132	23132 CCK/W33	22232 CCK/W33
		210	147	28	M 160×3	8,80	H 2332	23232 CCK/W33	22332 CCK/W33
150	170	200	101	28,5	M 170×3	5,80	H 3034	23034 CCK/W33	
		220	122	29	M 170×3	8,10	H 3134	23134 CCK/W33	22234 CCK/W33
		220	154	29	M 170×3	9,90	H 2334	23234 CCK/W33	22334 CCK/W33
160	180	210	109	29,5	M 180×3	6,70	H 3036	23036 CCK/W33	
		230	131	30	M 180×3	9,15	H 3136	23136 CCK/W33	22236 CCK/W33
		230	161	30	M 180×3	11,0	H 2336	23236 CCK/W33	22336 CCK/W33
170	190	220	112	30,5	M 190×3	7,25	H 3038	23038 CCK/W33	
		240	141	31	M 190×3	10,5	H 3138	23138 CCK/W33	22238 CCK/W33
180	200	240	120	31,5	M 200×3	8,90	H 3040	23040 CCK/W33	
		250	150	32	M 200×3	12,0	H 3140	23140 CCK/W33	22240 CCK/W33
		250	176	32	M 200×3	13,5	H 2340	23240 CCK/W33	22340 CCK/W33
200	220	260	126	30	Tr 220×4	9,90	OH 3044 H	23044 CCK/W33	
		280	161	35	Tr 220×4	15,0	OH 3144 H	23144 CCK/W33	22244 CCK/W33
220	240	290	133	34	Tr 240×4	12,0	OH 3048 H	23048 CCK/W33	
		300	172	37	Tr 240×4	16,0	OH 3148 H	23148 CCK/W33	22248 CCK/W33
240	260	310	145	34	Tr 260×4	13,5	OH 3052 H	23052 CCK/W33	
		330	190	39	Tr 260×4	21,0	OH 3152 H	23152 CCK/W33	
260	280	330	152	38	Tr 280×4	16,0	OH 3056 H	23056 CCK/W33	
		350	195	41	Tr 280×4	23,0	OH 3156 H	23156 CCK/W33	
280	300	360	168	42	Tr 300×4	20,5	OH 3060 H	23060 CCK/W33	
		380	208	40	Tr 300×4	29,0	OH 3160 H	23160 CCK/W33	



Withdrawal sleeves

d_1 35–115 mm

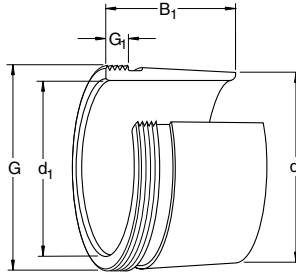

Dimensions					Mass	Designation Withdrawal sleeve	Appropriate self-aligning ball bearings and spherical roller bearings			
d_1	d	B_1	G	G_1						
mm					kg	–	–			
35	40	29	M 45×1,5	6	0,09	AH 308	1308 EK	2208 EK	21308 CCK 22208 EK	
		40	M 45×1,5	7	0,13	AH 2308	2308 EK	22308 EK		
40	45	31	M 50×1,5	6	0,12	AH 309	1309 EK	2209 EK	21309 EK	22209 CCK
		44	M 50×1,5	7	0,16	AH 2309	2309 EK	22309 CCK		
45	50	35	M 55×2	7	0,13	AHX 310	1310 EK	2210 EK	21310 EK	22210 EK
		50	M 55×2	9	0,19	AHX 2310	2310 K	22310 EK		
50	55	37	M 60×2	7	0,16	AHX 311	1311 EK	2211 EK	21311 EK	22211 EK
		54	M 60×2	10	0,26	AHX 2311	2311 K	22311 EK		
55	60	40	M 65×2	8	0,19	AHX 312	1312 EK	2212 EK	21312 EK	22212 EK
		58	M 65×2	11	0,30	AHX 2312	2312 K	22312 EK		
60	65	42	M 75×2	8	0,25	AH 313 G	1313 EK	2213 EK	21313 EK	22213 CCK
		61	M 75×2	12	0,39	AH 2313	2313 K	22313 EK		
65	70	43	M 80×2	8	0,29	AH 314 G	21314 EK	22214 EK		
		64	M 80×2	12	0,45	AHX 2314	22314 EK			
70	75	45	M 85×2	8	0,32	AH 315 G	1315 K	2215 EK	21315 EK	22215 EK
		68	M 85×2	12	0,53	AHX 2315	2315 K	22315 EK		
75	80	48	M 90×2	8	0,37	AH 316	1316 K	2216 EK	21316 EK	22216 EK
		71	M 90×2	12	0,57	AHX 2316	2316 K	22316 EK		
80	85	52	M 95×2	9	0,43	AHX 317	1317 K	2217 K	21317 EK	22217 EK
		74	M 95×2	13	0,65	AHX 2317	2317 KM	22317 EK		
85	90	53	M 100×2	9	0,46	AHX 318	1318 K	2218 K	21318 EK	22218 EK
		63	M 100×2	10	0,57	AHX 3218	23218 CCK	22318 EK		
		79	M 100×2	14	0,76	AHX 2318	2318 KM			
90	95	57	M 105×2	10	0,54	AHX 319	22219 EK			
		85	M 105×2	16	0,90	AHX 2319	22319 EK			
95	100	59	M 110×2	10	0,58	AHX 320	1320 K	2220 KM	22220 EK	
		64	M 110×2	11	0,66	AHX 3120	23120 CCK/W33			
		73	M 110×2	11	0,76	AHX 3220	23220 CCK/W33			
		90	M 110×2	16	1,00	AHX 2320	22320 EK			
105	110	68	M 120×2	11	0,76	AHX 3122	22222 CCK/W33	23122 CCK/W33		
		82	M 125×2	11	1,05	AHX 3222	23222 CCK/W33			
		98	M 125×2	16	1,35	AHX 2322	22322 EK			
		82	M 115×2	13	0,71	AH 24122	24122 CCK30/W33			
115	120	60	M 130×2	13	0,73	AHX 3024	23024 CCK/W33			
		75	M 130×2	12	0,94	AHX 3124	22224 CCK/W33	23124 EK		
		90	M 135×2	13	1,30	AHX 3224	23224 CCK/W33			
		105	M 135×2	17	1,65	AHX 2324	22324 CCK/W33	22324 CCK/W33		
		73	M 125×2	13	0,70	AH 24024	24024 CCK30/W33			
93	M 130×2	13	1,00	AH 24124	24124 CCK30/W33					

Withdrawal sleeves

d₁ 125–200 mm

Dimensions					Mass	Designation	Appropriate spherical roller bearings	
d ₁	d	B ₁	G	G ₁		Withdrawal sleeve		
mm					kg	–	–	
125	130	67	M 140×2	14	0,91	AHX 3026	23026 CCK/W33	23126 EK
		78	M 140×2	12	1,10	AHX 3126	22226 CCK/W33	
		98	M 145×2	15	1,55	AHX 3226	23226 CCK/W33	
		115	M 145×2	19	2,00	AHX 2326	22326 CCK/W33	
	83	M 135×2	14	0,88	AH 24026	24026 CCK30/W33	24126 CCK30/W33	
	94	M 140×2	14	1,15	AH 24126			
135	140	68	M 150×2	14	1,00	AH 3028	23028 CCK/W33	23128 CCK/W33
		83	M 150×2	14	1,30	AHX 3128	22228 CCK/W33	
		104	M 155×3	15	1,85	AHX 3228	23228 CCK/W33	
		125	M 155×3	20	2,35	AHX 2328	22328 CCK/W33	
	83	M 145×2	14	0,95	AH 24028	24028 CCK30/W33	24128 CCK30/W33	
	99	M 150×2	14	1,30	AH 24128			
145	150	72	M 160×3	15	1,15	AHX 3030	23030 CCK/W33	23130 CCK/W33
		96	M 165×3	15	1,80	AHX 3130	22230 CCK/W33	
		114	M 165×3	17	2,20	AHX 3230	23230 CCK/W33	
		135	M 165×3	24	2,80	AHX 2330	22330 CCK/W33	
	90	M 155×3	15	1,05	AH 24030	24030 CCK30/W33	24130 CCK30/W33	
	115	M 160×3	15	1,55	AH 24130			
150	160	77	M 170×3	16	2,05	AHX 3032	23032 CCK/W33	23132 CCK/W33
		103	M 180×3	16	3,20	AHX 3132	22232 CCK/W33	
		124	M 180×3	20	4,00	AHX 3232	23232 CCK/W33	
		140	M 180×3	24	4,65	AHX 2332	22332 CCK/W33	
	95	M 170×3	15	2,30	AH 24032	24032 CCK30/W33	24132 CCK30/W33	
	124	M 170×3	15	3,05	AH 24132			
160	170	85	M 180×3	17	2,40	AH 3034	23034 CCK/W33	23134 CCK/W33
		104	M 190×3	16	3,45	AH 3134	22234 CCK/W33	
		134	M 190×3	24	4,80	AH 3234	23234 CCK/W33	
		146	M 190×3	24	5,25	AH 2334	22334 CCK/W33	
	106	M 180×3	16	2,70	AH 24034	24034 CCK30/W33	24134 CCK30/W33	
	125	M 180×3	16	3,25	AH 24134			
170	180	92	M 190×3	17	2,80	AH 3036	23036 CCK/W33	23136 CCK/W33
		105	M 200×3	17	3,75	AH 2236	22236 CCK/W33	
		116	M 200×3	19	4,25	AH 3136	23136 CCK/W33	
		140	M 200×3	24	5,25	AH 3236	23236 CCK/W33	
	154	M 200×3	26	6,05	AH 2336	22336 CCK/W33		
	116	Tr 190×3	16	3,20	AH 24036	24036 CCK30/W33	24136 CCK30/W33	
134	Tr 190×3	16	3,75	AH 24136				
180	190	96	Tr 205×4	18	3,40	AH 3038	23038 CCK/W33	23138 CCK/W33
		112	Tr 210×4	18	4,25	AH 2238	22238 CCK/W33	
		125	Tr 210×4	20	4,90	AH 3138	23138 CCK/W33	
		145	Tr 210×4	25	5,90	AH 3238	23238 CCK/W33	
	160	Tr 210×4	26	6,60	AH 2338	22338 CCK/W33		
	118	Tr 200×3	18	3,55	AH 24038	24040 CCK30/W33	24140 CCK30/W33	
146	Tr 200×3	18	4,45	AH 24138				
190	200	102	Tr 215×4	19	3,85	AH 3040	23040 CCK/W33	23140 CCK/W33
		134	Tr 220×4	21	5,65	AH 3140	22240 CCK/W33	
		153	Tr 220×4	25	6,60	AH 3240	23240 CCK/W33	
		170	Tr 220×4	30	7,60	AH 2340	22340 CCK/W33	
	127	Tr 210×3	18	4,00	AH 24040	24040 CCK30/W33	24140 CCK30/W33	
	158	Tr 210×3	18	5,05	AH 24140			
200	220	111	Tr 235×4	20	7,40	AOH 3044	23044 CCK/W33	23144 CCK/W33
		145	Tr 240×4	23	9,30	AOH 3144	22244 CCK/W33	
		181	Tr 240×4	30	13,5	AOH 2344	22344 CCK/W33	



Withdrawal sleeves

d₁ 200–280 mm

Dimensions					Mass	Designation Withdrawal sleeve	Appropriate spherical roller bearings		
d ₁	d	B ₁	G	G ₁					
mm					kg	–	–		
200 (cont.)	220	138	Tr 230×4	20	8,20	AOH 24044	24044 CCK30/W33		
		170	Tr 230×4	20	10,0	AOH 24144	24144 CCK30/W33		
220	240	116	Tr 260×4	21	7,95	AOH 3048	23044 CCK/W33		
		154	Tr 260×4	25	12,0	AOH 3148	22248 CCK/W33		
		189	Tr 260×4	30	14,0	AOH 2348	22348 CCK/W33		
		138	Tr 250×4	20	8,05	AOH 24048	24048 CCK30/W33		
		180	Tr 260×4	20	11,5	AOH 24148	24148 CCK30/W33		
240	260	128	Tr 280×4	23	9,60	AOH 3052	23052 CCK/W33		
		172	Tr 290×4	26	16,0	AOH 3152	23152 CCK/W33		
		205	Tr 290×4	30	17,5	AOH 2352	23252 CCK/W33		
		162	Tr 270×4	22	10,5	AOH 24052	24052 CCK30/W33		
		202	Tr 280×4	22	14,0	AOH 24152	24152 CCK30/W33		
		260	280	131	Tr 300×4	24	11,0	AOH 3056	23056 CCK/W33
175	Tr 310×4			28	15,5	AOH 3156	23156 CCK/W33		
212	Tr 310×4			30	19,5	AOH 2356	23256 CCK/W33		
162	Tr 290×4			22	11,5	AOH 24056	24056 CCK30/W33		
202	Tr 300×4			22	15,0	AOH 24156	24156 CCK30/W33		
280	300			145	Tr 320×5	26	13,0	AOH 3060	23060 CCK/W33
				192	Tr 330×5	30	19,0	AOH 3160	23160 CCK/W33
		184	Tr 310×5	24	14,0	AOH 24060	24060 CCK30/W33		
								23144 CCK/W33 23244 CCK/W33	

Spherical plain bearings

Spherical plain bearings are designed to take up alignment movements between shaft and housing or predominantly oscillating tilting movements at relatively low sliding speeds.

SKF spherical plain bearings are available as radial, angular contact and thrust bearings either as steel-on-steel bearings which require relubrication or as maintenance-free bearings. SKF spherical plain bearings have designs which are well-proven and reliable. They meet most designer demands and the design, materials and quality provide long life and operational reliability. A new multi-groove system in the larger steel-on-steel bearings serves to improve lubrication and gives appreciably extended relubrication intervals.

Range

The SKF popular range comprises all popular sizes of

- radial spherical plain bearings (1),
- angular contact spherical plain bearings (2) and
- spherical plain thrust bearings (3)

SKF steel-on-steel spherical plain bearings have hardened and phosphated sliding contact surfaces and require lubrication. Those bearings having a bore diameter of 100 mm and above have a special multi-groove system in the outer ring which makes them insensitive to contamination and ensures good lubrication. SKF steel-on-steel spherical plain bearings are available as standard with or without seals.

SKF maintenance-free spherical plain bearings, depending on series and size, are available with the following sliding contact surface combinations: steel/sinter bronze composite, steel/PTFE fabric or steel/PTFE composite. The bearings are with or without seals, as required.

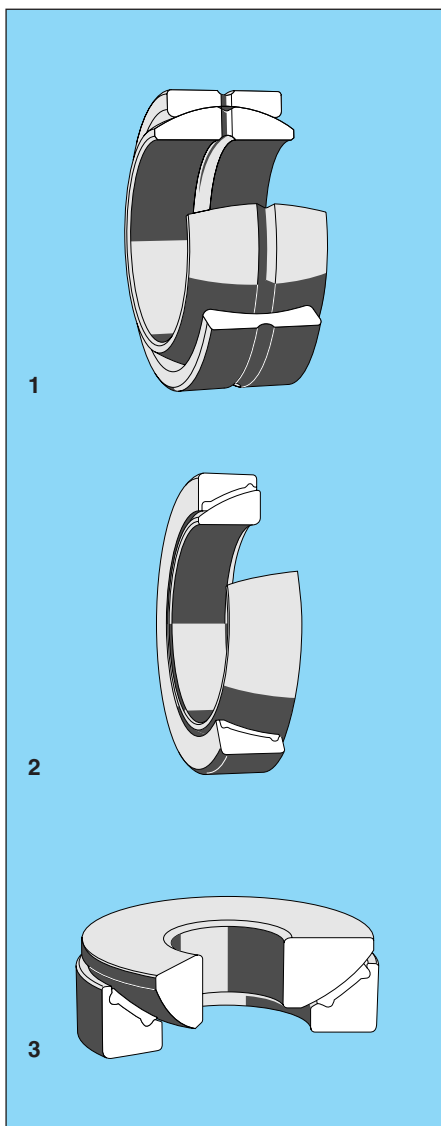

Spherical plain bearings

Sealed SKF spherical plain bearings can be used at temperatures between -30 and $+130$ °C.

Dimensions

The boundary dimensions of SKF spherical plain bearings listed in the tables are in accordance with ISO 12240-1 and ISO 6124.

Tolerances

SKF spherical plain bearings are produced to the tolerances specified in ISO 12240-1 and ISO 6125-1982.

Internal clearance

SKF steel-on-steel radial spherical plain bearings are produced as standard with Normal internal clearance according to ISO 12240-1. Some sizes are also available with smaller or larger clearance. Availability should be checked before ordering.

Supplementary designations

The suffixes which are frequently used with SKF spherical plain bearings are explained in the following.

A	Two-part outer ring
C	Sliding contact surface combination steel/sinter bronze composite
E	Outer ring split at predetermined position
ES	E + S
F	Sliding contact surface combination steel/PTFE composite
GR	Bearing rings of stainless steel
S	Annular groove and two lubrication holes in inner and outer rings
SA	Annular groove and two lubrication holes in outer ring
2RS	Double lip seals (rubbing seals) of polyester elastomer at both sides of bearing
T	Sliding contact surface combination steel/PTFE fabric
TA	T + A
TE	T + E
TGR	T + GR

Steel-on-steel spherical plain bearings

d 4–300 mm

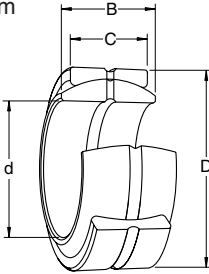

Dimensions				Basic load rating dynamic C	Mass	Designation
d	D	B	C			
mm				kN	kg	–
4	12	5	3	2,04	0,003	GE 4 E
5	14	6	4	3,40	0,004	GE 5 E
6	14	6	4	3,40	0,004	GE 6 E
8	16	8	5	5,50	0,008	GE 8 E
10	19	9	6	8,15	0,012	GE 10 E
12	22	10	7	10,8	0,017	GE 12 E
15	26	12	9	17	0,032	GE 15 ES
17	30	14	10	21,2	0,050	GE 17 ES
20	35	16	12	30	0,065	GE 20 ES
	35	16	12	30	0,065	GE 20 ES-2RS
	42	25	16	48	0,16	GEH 20 ES-2RS
25	42	20	16	48	0,12	GE 25 ES
	42	20	16	48	0,12	GE 25 ES-2RS
	47	28	18	62	0,20	GEH 25 ES-2RS
30	47	22	18	62	0,16	GE 30 ES
	47	22	18	62	0,16	GE 30 ES-2RS
	55	32	20	80	0,35	GEH 30 ES-2RS
35	55	25	20	80	0,23	GE 35 ES
	55	25	20	80	0,23	GE 35 ES-2RS
	62	35	22	100	0,47	GEH 35 ES-2RS
40	62	28	22	100	0,32	GE 40 ES
	62	28	22	100	0,32	GE 40 ES-2RS
	68	40	25	127	0,61	GEH 40 ES-2RS
45	68	32	25	127	0,46	GE 45 ES
	68	32	25	127	0,46	GE 45 ES-2RS
	75	43	28	156	0,80	GEH 45 ES-2RS
50	75	35	28	156	0,56	GE 50 ES
	75	35	28	156	0,56	GE 50 ES-2RS
	90	56	36	245	1,60	GEH 50 ES-2RS
60	90	44	36	245	1,10	GE 60 ES
	90	44	36	245	1,10	GE 60 ES-2RS
	105	63	40	315	2,40	GEH 60 ES-2RS
70	105	49	40	315	1,55	GE 70 ES
	105	49	40	315	1,55	GE 70 ES-2RS
	120	70	45	400	3,40	GEH 70 ES-2RS
80	120	55	45	400	2,30	GE 80 ES
	120	55	45	400	2,30	GE 80 ES-2RS
	130	75	50	490	4,10	GEH 80 ES-2RS

Dimensions				Basic load rating dynamic C	Mass	Designation
d	D	B	C			
mm				kN	kg	–
90	130	60	50	490	2,75	GE 90 ES
	130	60	50	490	2,75	GE 90 ES-2RS
	150	85	55	610	6,30	GEH 90 ES-2RS
100	150	70	55	610	4,40	GE 100 ES
	150	70	55	610	4,40	GE 100 ES-2RS
	160	85	55	655	6,80	GEH 100 ES-2RS
110	160	70	55	655	4,80	GE 110 ES
	160	70	55	655	4,80	GE 110 ES-2RS
	180	100	70	950	11,0	GEH 110 ES-2RS
120	180	85	70	950	8,25	GE 120 ES
	180	85	70	950	8,25	GE 120 ES-2RS
140	210	90	70	1 080	11,0	GE 140 ES
	210	90	70	1 080	11,0	GE 140 ES-2RS
160	230	105	80	1 370	14,0	GE 160 ES
	230	105	80	1 370	14,0	GE 160 ES-2RS
180	260	105	80	1 530	18,5	GE 180 ES
	260	105	80	1 530	18,5	GE 180 ES-2RS
200	290	130	100	2 120	28,0	GE 200 ES
	290	130	100	2 120	28,0	GE 200 ES-2RS
220	320	135	100	2 320	35,5	GE 220 ES-2RS
240	340	140	100	2 550	40,0	GE 240 ES-2RS
260	370	150	110	3 050	51,5	GE 260 ES-2RS
280	400	155	120	3 550	65,0	GE 280 ES-2RS
300	430	165	120	3 800	78,5	GE 300 ES-2RS

**Steel-on-steel spherical plain bearings
with extended inner ring**

d 20–100 mm

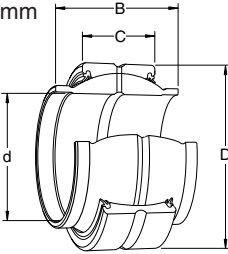

Designation				Basic load rating dynamic C	Mass	Designation
d	D	B	C			
mm				kN	kg	–
20	35	24	12	30	0,073	GEM 20 ES-2RS
25	42	29	16	48	0,13	GEM 25 ES-2RS
30	47	30	18	62	0,17	GEM 30 ES-2RS
35	55	35	20	80	0,25	GEM 35 ES-2RS
40	62	38	22	100	0,35	GEM 40 ES-2RS
	62	40	22	100	0,34	GEG 40 ES
45	68	40	25	127	0,49	GEM 45 ES-2RS
50	75	43	28	156	0,60	GEM 50 ES-2RS
	75	50	28	156	0,56	GEG 50 ES
60	90	54	36	245	1,15	GEM 60 ES-2RS
63	95	63	36	255	1,25	GEG 63 ES
70	105	65	40	315	1,65	GEM 70 ES-2RS
80	120	80	45	400	2,40	GEG 80 ES
100	150	100	55	610	4,80	GEG 100 ES

Maintenance-free spherical plain bearings, steel/sinter bronze composite
d 4–30 mm

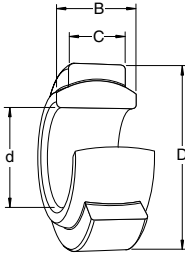

Maintenance-free spherical plain bearings, steel/PTFE fabric
d 30–300 mm

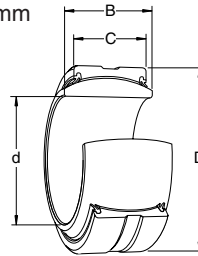

Dimensions	Basic load rating dynamic C	Mass	Designation	Dimensions			
				d	D	B	C
mm	kN	kg	–				
4	12	5	3	2,16	0,003	GE 4 C	
6	14	6	4	3,60	0,004	GE 6 C	
8	16	8	5	5,85	0,008	GE 8 C	
10	19	9	6	8,65	0,012	GE 10 C	
	22	12	7	11,4	0,020	GEH 10 C	
12	22	10	7	11,4	0,017	GE 12 C	
	26	15	9	18	0,030	GEH 12 C	
15	26	12	9	18	0,032	GE 15 C	
	30	16	10	22,4	0,050	GEH 15 C	
17	30	14	10	22,4	0,050	GE 17 C	
	35	20	12	31,5	0,090	GEH 17 C	
20	35	16	12	31,5	0,065	GE 20 C	
	42	25	16	51	0,16	GEH 20 C	
25	42	20	16	51	0,12	GE 25 C	
	47	28	18	65,5	0,20	GEH 25 C	
30	47	22	18	65,5	0,16	GE 30 C	

Dimensions	Basic load rating dynamic C	Mass	Designation	Dimensions			
				d	D	B	C
mm	kN	kg	–				
30	47	22	18	88	0,16	GE 30 TE-2RS	
	47	22	18	88	0,16	GE 30 TGR¹⁾	
35	55	25	20	112	0,23	GE 35 TE-2RS	
	55	25	20	112	0,23	GE 35 TGR¹⁾	
40	62	28	22	140	0,32	GE 40 TE-2RS	
45	68	32	25	180	0,46	GE 45 TE-2RS	
50	75	35	28	220	0,56	GE 50 TE-2RS	
60	90	44	36	345	1,10	GE 60 TE-2RS	
70	105	49	40	440	1,55	GE 70 TE-2RS	
80	120	55	45	570	2,30	GE 80 TE-2RS	
90	130	60	50	695	2,75	GE 90 TE-2RS	
100	150	70	55	865	4,40	GE 100 TA-2RS	
110	160	70	55	930	4,80	GE 110 TA-2RS	
120	180	85	70	1 340	8,25	GE 120 TA-2RS	
140	210	90	70	1 500	11,0	GE 140 TA-2RS	
160	230	105	80	1 930	14,0	GE 160 TA-2RS	
180	260	105	80	2 160	18,5	GE 180 TA-2RS	
200	290	130	100	3 000	28,0	GE 200 TA-2RS	
220	320	135	100	3 350	35,5	GE 220 TA-2RS	
240	340	140	100	3 600	40,0	GE 240 TA-2RS	
260	370	150	110	4 300	51,5	GE 260 TA-2RS	
280	400	155	120	5 000	65,0	GE 280 TA-2RS	
300	430	165	120	5 400	78,5	GE 300 TA-2RS	



¹⁾ Bearing made of stainless steel

Maintenance-free angular contact spherical plain bearings, steel/PTFE composite
d 25–100 mm

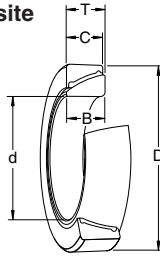

Dimensions				Basic load rating dynamic C	Mass	Designation
d	D	T/B	C			
mm				kN	kg	–
25	47	15	14	21,6	0,14	GAC 25 F
30	55	17	15	27	0,21	GAC 30 F
35	62	18	16	32,5	0,27	GAC 35 F
40	68	19	17	39	0,33	GAC 40 F
45	75	20	18	45,5	0,42	GAC 45 F
50	80	20	19	53	0,46	GAC 50 F
60	95	23	21	69,5	0,73	GAC 60 F
70	110	25	23	88	1,05	GAC 70 F
80	125	29	25,5	110	1,55	GAC 80 F
90	140	32	28	134	2,10	GAC 90 F
100	150	32	31	170	2,35	GAC 100 F

Maintenance-free spherical plain thrust bearings, steel/PTFE composite
d 17–120 mm

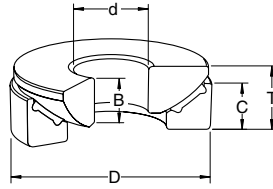

Dimensions				Basic load rating dynamic C	Mass	Designation
d	D	T	B/C			
mm				kN	kg	–
17	47	16	11,8/11,2	36,5	0,14	GX 17 F
20	55	20	14,5/13,8	46,5	0,25	GX 20 F
25	62	22,5	16,5/16,7	69,5	0,42	GX 25 F
30	75	26	19/19	95	0,61	GX 30 F
35	90	28	22/20,7	134	0,98	GX 35 F
40	105	32	27/21,5	173	1,50	GX 40 F
45	120	36,5	31/25,5	224	2,25	GX 45 F
50	130	42,5	33/30,5	275	3,15	GX 50 F
60	150	45	37/34	375	4,65	GX 60 F
70	160	50	42/36,5	475	5,40	GX 70 F
80	180	50	43,5/38	570	6,95	GX 80 F
100	210	59	51/46	735	11,0	GX 100 F
120	230	64	53,5/50	880	14,0	GX 120 F

Rod ends

Rod ends comprise a rod end housing and a standard radial spherical plain bearing or a rod end housing with spherical plain bearing inner ring and dry sliding insert.

SKF rod ends are available as steel-on-steel or steel-on-bronze rod ends which require lubrication or as maintenance-free rod ends. The designs are well-proven and reliable.

SKF rod ends enable cost saving, operationally reliable designs to be achieved and have long service lives. Their price/performance ratio is particularly favourable.

Range

The rod ends of the SKF popular range are produced with female (internal) thread (1) and male (external) thread (2), right-hand threads being standard. Rod ends with left-hand threads must be specially ordered. SKF also produces rod ends with welding shank (3).

All SKF steel-on-bronze rod ends can be relubricated via a grease nipple as can SKF steel-on-steel rod ends from size 25 and above.

Depending on size and series, SKF maintenance-free rod ends have the following sliding contact surface combinations: steel/sinter bronze composite, steel/PTFE composite and steel/PTFE fabric.

Dimensions

The dimensions of the rod ends are in accordance with ISO 12240-4 and ISO 6126 with the exception of series SIR, SIRD, SIQG and SCF. The dimensions of series SIQG conform to ISO 6982.

Tolerances

SKF rod ends are produced to the tolerances specified in ISO 12240-4.

Internal clearance

SKF steel-on-steel rod ends are produced as standard with Normal radial internal clearance according to ISO 12240-4.

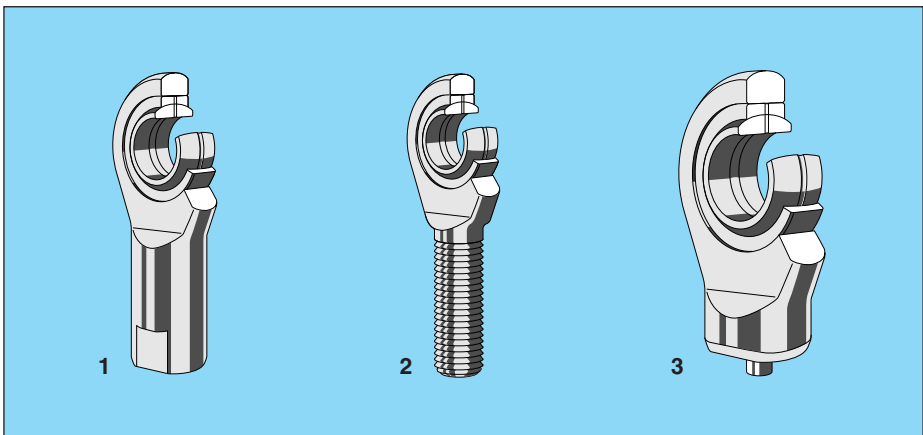

Rod ends

Supplementary designations

The suffixes frequently used with SKF rod ends are explained in the following.

- C** Sliding contact surface combination steel/sinter bronze composite
- E** Rod end bearing has ring which is split at a predetermined position
- ES** E + S
- ESA** E + SA
- F** Sliding contact surface combination steel/PTFE composite
- M** Sliding contact surface combination steel-on-bronze
- 2RS** Double lip seal (rubbing seal) of polyester elastomer at both sides of inserted bearing
- S** Relubrication facility in rod end housing and inner ring
- SA** Relubrication facility in rod end housing
- T** Sliding contact surface combination steel/PTFE fabric
- TE** T + E

Steel-on-steel rod ends with female or male thread
d 6–80 mm

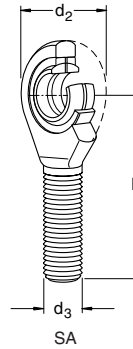
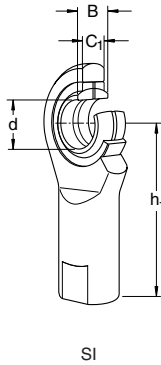

Dimensions		Basic load rating dynamic C	Masses		Designations ¹⁾						
d	d ₂ max		SI	SA	Rod end with right-hand female thread	male thread					
d	d ₂ max	d ₃	B	C ₁ max	h	h ₁	kN	kg	–		
mm							kN	kg	–		
6	22	M 6	6	4,5	36	30	3,4	0,020	0,015	SI 6 E	SA 6 E
8	25	M 8	8	6,5	42	36	5,5	0,039	0,029	SI 8 E	SA 8 E
10	30	M 10	9	7,5	48	43	8,15	0,069	0,049	SI 10 E	SA 10 E
12	35	M 12	10	8,5	54	50	10,8	0,11	0,071	SI 12 E	SA 12 E
15	41	M 14	12	10,5	63	61	17	0,18	0,13	SI 15 ES	SA 15 ES
17	47	M 16	14	11,5	69	67	21,2	0,25	0,19	SI 17 ES	SA 17 ES
20	54	M 20×1,5	16	13,5	78	77	30	0,34	0,29	SI 20 ES	SA 20 ES
25	65	M 24×2	20	18	94	94	48	0,65	0,53	SI 25 ES	SA 25 ES
30	75	M 30×2	22	20	110	110	62	1,00	0,87	SI 30 ES	SA 30 ES
35	84	M 36×3	25	22	130	130	80	1,40	1,30	SI 35 ES	SA 35 ES
40	94	M 42×3	28	24	145	145	100	2,20	1,90	SI 40 ES	SA 40 ES
45	104	M 45×3	32	28	165	–	127	–	2,55	–	SA 45 ES
50	114	M 52×3	35	31	195	195	156	4,10	3,70	SI 50 ES	SA 50 ES
60	137	M 60×4	44	39	225	225	245	7,10	6,25	SI 60 ES	SA 60 ES
70	162	M 72×4	49	43	265	265	315	10,5	10,0	SI 70 ES	SA 70 ES
80	182	M 80×4	55	48	295	295	400	15,0	14,5	SI 80 ES	SA 80 ES

Rod ends from 25 mm bore diameter are supplied with a cup-type lubrication nipple (to DIN 71 412) as standard

¹⁾ Rod ends with left-hand thread are designated SIL .. and SAL .. respectively; please check availability



**Steel-on-steel rod ends with female thread
(for hydraulic cylinders)**
d 12–100 mm

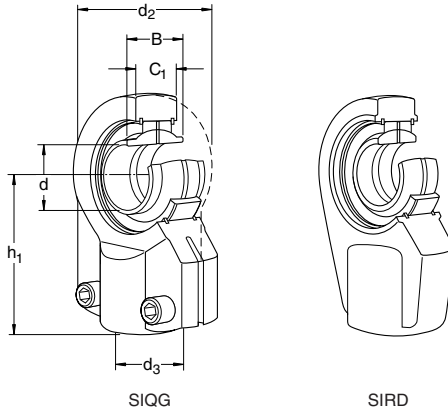

Dimensions						Basic load rating dynamic C	Mass	Designations ¹⁾	
d	d ₂ max	d ₃	B	C ₁ max	h ₁			Rod end with right-hand thread compressible	not compressible
mm						kN	kg	–	
12	33	M 12×1,25	12	11	38	10,8	0,11	SIQG 12 ESA	–
16	41	M 14×1,5	16	15	44	17,6	0,21	SIQG 16 ES	–
20	50	M 16×1,5	20	19	52	30	0,40	SIQG 20 ES	–
	58	M 16×1,5	16	19,5	50	30	0,41	SIR 20 ES	SIRD 20 ES
25	62	M 20×1,5	25	23	65	48	0,66	SIQG 25 ES	–
	58	M 16×1,5	20	23,5	50	48	0,47	SIR 25 ES	SIRD 25 ES
30	66	M 22×1,5	22	28,5	60	62	0,77	SIR 30 ES	SIRD 30 ES
32	76	M 27×2	32	29	80	65,5	1,20	SIQG 32 ES	–
35	80	M 28×1,5	25	30,5	70	80	1,20	SIR 35 ES	SIRD 35 ES
40	97	M 33×2	40	34	97	100	2,05	SIQG 40 ES	–
	96	M 35×1,5	28	35,5	85	100	1,40	SIR 40 ES	SIRD 40 ES
50	118	M 42×2	50	42	120	156	4,45	SIQG 50 ES	–
	118	M 45×1,5	35	40,5	105	156	3,60	SIR 50 ES	SIRD 50 ES
60	132	M 58×1,5	44	50,5	130	245	6,00	SIR 60 ES	SIRD 60 ES
63	142	M 48×2	63	55	140	255	7,60	SIQG 63 ES	–
70	157	M 65×1,5	49	55,5	150	315	9,40	SIR 70 ES	SIRD 70 ES
80	180	M 64×3	80	69	180	400	14,5	SIQG 80 ES	–
	179	M 80×2	55	60,5	170	400	13,0	SIR 80 ES	SIRD 80 ES
100	224	M 80×3	100	87	210	610	28,0	SIQG 100 ES	–
	233	M 110×2	70	70,5	235	610	30,0	SIR 100 ES	SIRD 100 ES

Rod ends from 25 mm bore diameter are supplied with a cup-type lubrication nipple (to DIN 71 412) as standard

¹⁾ Rod ends with left-hand thread are designated SILQG ..., SILR .. and SILRD .. respectively; please check availability

Steel-on-steel rod ends with welding shank
d 20–100 mm

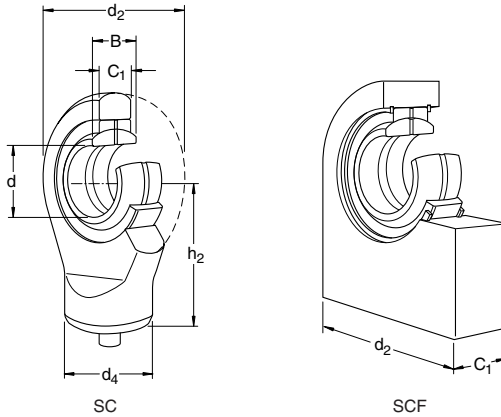

Dimensions			Basic load rating dynamic C	Mass kg	Designation			
d	d ₂ max	d ₄				B	C ₁ max	h ₂
mm			kN	kg	–			
20	54 51,5	29 –	16 16	13,5 20	38 38	30 30	0,24 0,35	SC 20 ES SCF 20 ES
25	65 56,5	35 –	20 20	18 24	45 45	48 48	0,43 0,53	SC 25 ES SCF 25 ES
30	75 66,5	42 –	22 22	20 29	51 51	62 62	0,65 0,87	SC 30 ES SCF 30 ES
35	84 85	49 –	25 25	22 31	61 61	80 80	1,00 1,55	SC 35 ES SCF 35 ES
40	94 102	54 –	28 28	24 36,5	69 69	100 100	1,40 2,45	SC 40 ES SCF 40 ES
45	104 112	60 –	32 32	28 41,5	77 77	127 127	1,90 3,40	SC 45 ES SCF 45 ES
50	114 125,5	64 –	35 35	31 41,5	88 88	156 156	2,50 4,45	SC 50 ES SCF 50 ES
60	137 142,5	72 –	44 44	39 51,5	100 100	245 245	4,20 7,10	SC 60 ES SCF 60 ES
70	162 166,5	82 –	49 49	43 57	115 115	315 315	5,80 10,5	SC 70 ES SCF 70 ES
80	182 182,5	97 –	55 55	48 62	141 141	400 400	9,70 15,0	SC 80 ES SCF 80 ES
100	252,5	–	70	72	170	610	31,5	SCF 100 ES

Rod ends from 25 mm bore diameter are supplied with a cup-type lubrication nipple (to DIN 71 412) as standard



Steel-on-bronze rod ends with female or male thread

d 5–30 mm

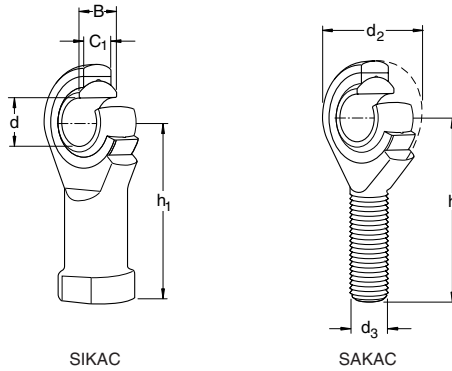

Dimensions			Basic load rating dynamic C	Masses		Designations ¹⁾					
d	d ₂ max	d ₃		B	C ₁ max	h	h ₁	SIKAC	SAKAC	Rod end with right-hand female thread	male thread
mm											
5	18	M 5	8	6	33	27	3,25	0,017	0,013	SIKAC 5 M	SAKAC 5 M
6	21	M 6	9	7,5	36	30	4,30	0,028	0,021	SIKAC 6 M	SAKAC 6 M
8	25	M 8	12	9,5	42	36	7,20	0,047	0,035	SIKAC 8 M	SAKAC 8 M
10	29	M 10	14	11,5	48	43	10	0,079	0,059	SIKAC 10 M	SAKAC 10 M
12	33	M 12	16	12,5	54	50	13,4	0,12	0,093	SIKAC 12 M	SAKAC 12 M
14	37	M 14	19	14,5	60	57	16	0,18	0,14	SIKAC 14 M	SAKAC 14 M
16	43	M 16	21	15,5	66	64	21,6	0,23	0,21	SIKAC 16 M	SAKAC 16 M
18	47	M 18×1,5	23	17,5	72	71	26	0,33	0,29	SIKAC 18 M	SAKAC 18 M
20	51	M 20×1,5	25	18,5	78	77	31,5	0,42	0,37	SIKAC 20 M	SAKAC 20 M
22	55	M 22×1,5	28	21	84	84	38	0,52	0,46	SIKAC 22 M	SAKAC 22 M
25	61	M 24×2	31	23	94	94	47,5	0,68	0,62	SIKAC 25 M	SAKAC 25 M
30	71	M 30×2	37	27	110	110	64	1,10	1,05	SIKAC 30 M	SAKAC 30 M

All rod ends are supplied with a funnel-type lubrication nipple (to DIN 3405) as standard

¹⁾ Rod ends with left-hand thread are designated SILKAC .. and SALKAC .. respectively; please check availability

**Maintenance-free rod ends with female or male thread,
steel/sinter bronze composite or steel/PTFE fabric
d 6–80 mm**

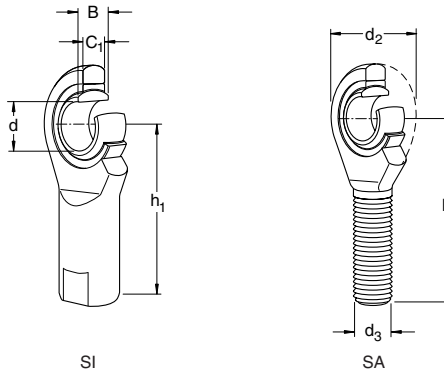

Dimensions			Basic load rating dynamic C	Masses		Designations ¹⁾					
d	d ₂ max	d ₃		SI	SA	Rod end with right-hand female thread	male thread				
mm			kN	kg	–						
6	22	M 6	6	4,5	36	30	3,60	0,020	0,015	SI 6 C	SA 6 C
8	25	M 8	8	6,5	42	36	5,85	0,039	0,029	SI 8 C	SA 8 C
10	30	M 10	9	7,5	48	43	8,65	0,069	0,049	SI 10 C	SA 10 C
12	35	M 12	10	8,5	54	50	11,4	0,11	0,071	SI 12 C	SA 12 C
15	41	M 14	12	10,5	63	61	18	0,18	0,13	SI 15 C	SA 15 C
17	47	M 16	14	11,5	69	67	22,4	0,25	0,19	SI 17 C	SA 17 C
20	54	M 20×1,5	16	13,5	78	77	31,5	0,34	0,29	SI 20 C	SA 20 C
25	65	M 24×2	20	18	94	94	51	0,65	0,53	SI 25 C	SA 25 C
30	75	M 30×2	22	20	110	110	65,5	1,00	0,87	SI 30 C	SA 30 C
35	84	M 36×3	25	22	130	–	112	–	1,30	–	SA 35 TE-2RS
40	94	M 42×3	28	24	145	145	140	2,20	1,90	SI 40 TE-2RS	SA 40 TE-2RS
45	104	M 45×3	32	28	165	165	180	3,20	2,55	SI 45 TE-2RS	SA 45 TE-2RS
50	114	M 52×3	35	31	195	195	220	4,10	3,70	SI 50 TE-2RS	SA 50 TE-2RS
60	137	M 60×4	44	39	225	225	345	7,10	6,25	SI 60 TE-2RS	SA 60 TE-2RS
70	162	M 72×4	49	43	265	265	440	10,5	10,0	SI 70 TE-2RS	SA 70 TE-2RS
80	182	M 80×4	55	48	295	295	570	15,0	14,5	SI 80 TE-2RS	SA 80 TE-2RS

¹⁾ Rod ends with left-hand thread are designated SIL ... and SAL ... respectively; please check availability



**Maintenance-free rod ends with female or male thread,
steel/PTFE composite**
d 5–22 mm

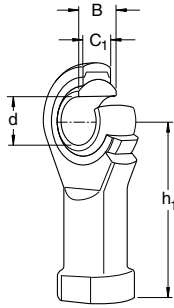

SIKB

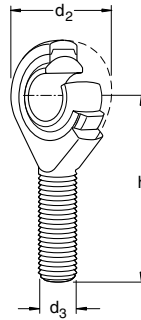

SAKB

Dimensions							Basic load rating dynamic C	Masses		Designations ¹⁾	
d	d ₂ max	d ₃	B	C ₁ max	h	h ₁		SIKB	SAKB	Rod end with right-hand female thread	male thread
mm							kN	kg		–	
5	19	M 5	8	7,5	33	27	3,25	0,019	0,014	SIKB 5 F	SAKB 5 F
6	21	M 6	9	7,5	36	30	4,25	0,028	0,021	SIKB 6 F	SAKB 6 F
8	25	M 8	12	9,5	42	36	7,10	0,047	0,035	SIKB 8 F	SAKB 8 F
10	29	M 10	14	11,5	48	43	9,80	0,079	0,059	SIKB 10 F	SAKB 10 F
12	33	M 12	16	12,5	54	50	13,2	0,12	0,093	SIKB 12 F	SAKB 12 F
14	37	M 14	19	14,5	60	57	17	0,18	0,14	SIKB 14 F	SAKB 14 F
16	43	M 16	21	15,5	66	64	21,4	0,23	0,21	SIKB 16 F	SAKB 16 F
18	47	M 18×1,5	23	17,5	72	71	26	0,33	0,29	SIKB 18 F	SAKB 18 F
20	51	M 20×1,5	25	18,5	78	77	31	0,42	0,37	SIKB 20 F	SAKB 20 F
22	55	M 22×1,5	28	21	84	84	38	0,52	0,46	SIKB 22 F	SAKB 22 F

¹⁾ Rod ends with left-hand thread are designated SILKB .. and SALKB .. respectively; please check availability

GLYCODUR® plain bearings

GLYCODUR® plain bearings are dry sliding bearings for rotational, oscillating or linear movements. They are particularly suitable for bearing arrangements where space is extremely limited, where freedom from maintenance is desired or where lubricant starvation can occur.

Two different materials are available: GLYCODUR F and GLYCODUR A. Both materials have a copper plated steel back on to which a layer of tin bronze is sintered.

The composition of GLYCODUR F guarantees good dimensional stability and heat conductance. Bearings of this material have good dry sliding properties and need not be relubricated.

GLYCODUR A has a 0,3 mm thick acetal resin layer which is firmly anchored in the sinter bronze. Lubricant pockets are formed in this layer, so that for bearings of this material a single initial grease filling is required on mounting. The acetal resin top layer also makes bearings of this material insensitive to a certain extent to slight errors of alignment and the edge stresses associated with this condition.

Range

In addition to the products shown in this catalogue

- GLY.PG bushings (1),
- GLY.PBG flanged bushings (2), and
- GLY.PXG thrust washers (3)

GLY.PLG strips having the dimensions 200 × 500 mm and large GLY.PG bushings for shafts with diameters greater than 200 mm also belong to the SKF popular range.

GLYCODUR® is the registered trade mark of the Glyco-Metall-Werke, Glyco B.V. & Co. KG, Wiesbaden, Germany.

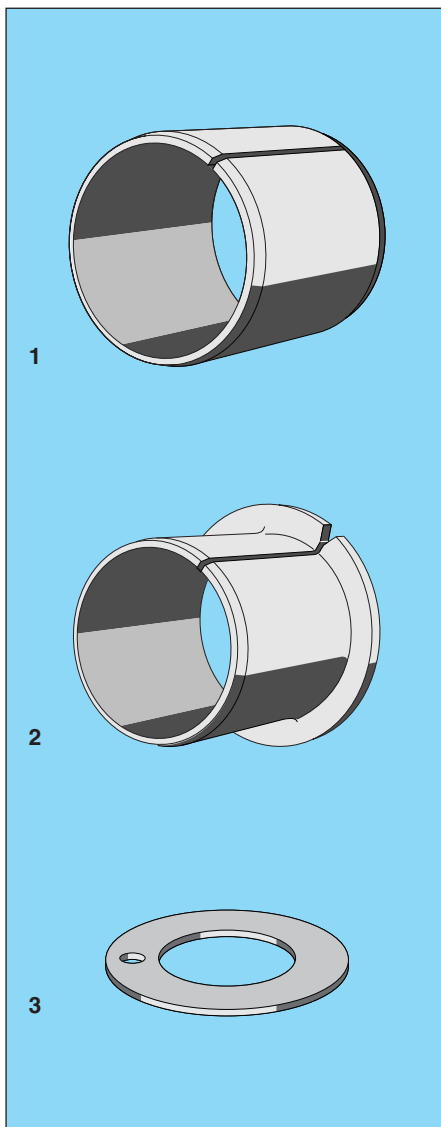

GLYCODUR plain bearings

SKF can also supply GLYCODUR bushings in inch sizes and GLYCODUR plain bearings with an extra-thick acetal resin layer which allows for subsequent machining of the sliding layer.

Dimensions

The dimensions of GLYCODUR bushings with bore diameters in the range 4 to 160 mm are largely in accordance with ISO 3547-1976.

Tolerances

The tolerances of the outside diameter of GLYCODUR bushings conform to DIN 1494 Part 1. The tolerance for the width of the bushings is $\pm 0,25$ mm.

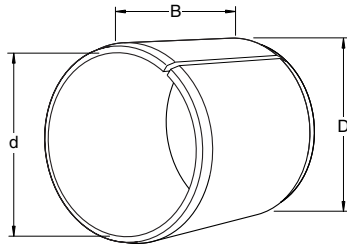

GLY.PG..F

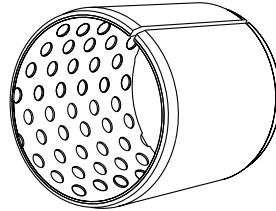

GLY.PG..A

GLYCODUR® bushings

d 3–18 mm

Dimensions			Basic load rating dynamic		Masses		Designations	
d	D	B	C Type F	A	F	A	F	A
mm			kN		g		–	
3	4,5	3	0,720	–	0,2	–	GLY.PG 030403 F/VB055	–
	4,5	5	1,2	–	0,3	–	GLY.PG 030405 F/VB055	–
	4,5	6	1,43	–	0,4	–	GLY.PG 030406 F/VB055	–
4	5,5	3	0,965	–	0,2	–	GLY.PG 040503 F/VB055	–
	5,5	4	1,27	–	0,3	–	GLY.PG 040504 F/VB055	–
	5,5	6	1,93	–	0,6	–	GLY.PG 040506 F/VB055	–
	5,5	10	3,2	–	0,8	–	GLY.PG 040510 F/VB055	–
5	7	5	2	–	0,7	–	GLY.PG 050705 F	–
	7	8	3,2	–	1,1	–	GLY.PG 050708 F	–
	7	10	4	–	1,4	–	GLY.PG 050710 F	–
6	8	6	2,9	–	1	–	GLY.PG 060806 F	–
	8	8	3,8	–	1,3	–	GLY.PG 060808 F	–
	8	10	4,8	–	1,6	–	GLY.PG 060810 F	–
7	9	10	5,6	–	1,8	–	GLY.PG 070910 F	–
8	10	8	5,1	7,65	1,7	1,3	GLY.PG 081008 F	GLY.PG 081008 A
	10	10	6,4	9,65	2,1	1,6	GLY.PG 081010 F	GLY.PG 081010 A
	10	12	7,65	11,6	2,5	1,9	GLY.PG 081012 F	GLY.PG 081012 A
10	12	8	6,4	–	2	–	GLY.PG 101208 F	–
	12	10	8	12	2,5	1,9	GLY.PG 101210 F	GLY.PG 101210 A
	12	12	9,65	14,3	3	2,3	GLY.PG 101212 F	GLY.PG 101212 A
	12	15	12	18	3,8	2,9	GLY.PG 101215 F	GLY.PG 101215 A
	12	20	16	24	5,1	3,9	GLY.PG 101220 F	GLY.PG 101220 A
12	14	8	7,65	–	2,4	–	GLY.PG 121408 F	–
	14	10	9,65	14,3	3	2,3	GLY.PG 121410 F	GLY.PG 121410 A
	14	12	11,6	17,3	3,6	2,8	GLY.PG 121412 F	GLY.PG 121412 A
	14	15	14,3	21,6	4,5	3,5	GLY.PG 121415 F	GLY.PG 121415 A
	14	20	19,3	29	6	4,6	GLY.PG 121420 F	GLY.PG 121420 A
	14	25	24	36	7,6	5,8	GLY.PG 121425 F	GLY.PG 121425 A
13	15	10	10,4	–	3,2	–	GLY.PG 131510 F	–
	15	20	20,8	–	6,3	–	GLY.PG 131520 F	–
14	16	10	11,2	–	3,5	–	GLY.PG 141610 F	–
	16	12	13,4	–	4,2	–	GLY.PG 141612 F	–
	16	15	16,6	25	5,2	4	GLY.PG 141615 F	GLY.PG 141615 A
	16	20	22,4	33,5	7	5,3	GLY.PG 141620 F	GLY.PG 141620 A
	16	25	28	41,5	8,7	6,6	GLY.PG 141625 F	GLY.PG 141625 A
15	17	10	12	18	3,7	2,8	GLY.PG 151710 F	GLY.PG 151710 A
	17	12	14,3	21,6	4,4	3,4	GLY.PG 151712 F	GLY.PG 151712 A
	17	15	18	27	5,6	4,3	GLY.PG 151715 F	GLY.PG 151715 A
	17	20	24	–	7,4	–	GLY.PG 151720 F	–
	17	25	30	–	9,3	–	GLY.PG 151725 F	–
16	18	10	12,9	–	3,9	–	GLY.PG 161810 F	–
	18	12	15,3	–	4,7	–	GLY.PG 161812 F	–
	18	15	19,3	29	5,9	4,5	GLY.PG 161815 F	GLY.PG 161815 A
	18	20	25,5	38	7,9	6	GLY.PG 161820 F	GLY.PG 161820 A
	18	25	32	48	9,9	7,5	GLY.PG 161825 F	GLY.PG 161825 A
17	19	20	27	–	8,3	–	GLY.PG 171920 F	–
18	20	15	21,6	32,5	6,6	5	GLY.PG 182015 F	GLY.PG 182015 A
	20	20	29	43	8,8	6,7	GLY.PG 182020 F	GLY.PG 182020 A
	20	25	36	54	11	8,4	GLY.PG 182025 F	GLY.PG 182025 A



GLYCODUR® bushings

d 20–55 mm

Dimensions			Basic load rating dynamic		Masses		Designations	
d	D	B	C Type F	A	F	A	F	A
mm			kN		g		–	
20	22	10	–	22	–	3,3	–	GLY.PG 202210 A
	22	20	–	46,5	–	6,6	–	GLY.PG 202220 A
	23	10	14,6	22	7,4	6,4	GLY.PG 202310 F	GLY.PG 202310 A
	23	15	22,8	34	11	9,7	GLY.PG 202315 F	GLY.PG 202315 A
	23	20	30,5	46,5	15	13	GLY.PG 202320 F	GLY.PG 202320 A
	23	25	39	58,5	19	16	GLY.PG 202325 F	GLY.PG 202325 A
	23	30	46,5	69,5	23	19	GLY.PG 202330 F	GLY.PG 202330 A
22	24	20	–	51	–	7,3	–	GLY.PG 202420 A
	25	15	25	37,5	12	11	GLY.PG 222515 F	GLY.PG 222515 A
	25	20	34	51	16	14	GLY.PG 222520 F	GLY.PG 222520 A
	25	25	42,5	64	21	18	GLY.PG 222525 F	GLY.PG 222525 A
	25	30	51	76,5	25	21	GLY.PG 222530 F	GLY.PG 222530 A
24	27	15	27,5	–	13	–	GLY.PG 242715 F	–
	27	20	36,5	55	18	15	GLY.PG 242720 F	GLY.PG 242720 A
	27	25	46,5	–	22	–	GLY.PG 242725 F	–
	27	30	56	–	26	–	GLY.PG 242730 F	–
	28	25	46,5	–	28	–	GLY.PG 242825 F	–
25	28	15	28,5	42,5	14	12	GLY.PG 252815 F	GLY.PG 252815 A
	28	20	38	57	18	16	GLY.PG 252820 F	GLY.PG 252820 A
	28	25	48	72	23	20	GLY.PG 252825 F	GLY.PG 252825 A
	28	30	58,5	88	28	24	GLY.PG 252830 F	GLY.PG 252830 A
	28	50	98	–	47	–	GLY.PG 252850 F	–
28	32	15	32,3	–	19	–	GLY.PG 283215 F	–
	32	20	43	64	28	25	GLY.PG 283220 F	GLY.PG 283220 A
	32	25	54	81,5	35	32	GLY.PG 283225 F	GLY.PG 283225 A
	32	30	65,5	98	42	38	GLY.PG 283230 F	GLY.PG 283230 A
30	34	15	34	–	22	–	GLY.PG 303415 F	–
	34	20	46,5	69,5	30	27	GLY.PG 303420 F	GLY.PG 303420 A
	34	25	58,5	–	37	–	GLY.PG 303425 F	–
	34	30	69,5	106	45	41	GLY.PG 303430 F	GLY.PG 303430 A
	34	40	95	140	60	54	GLY.PG 303440 F	GLY.PG 303440 A
32	36	20	49	73,5	31	29	GLY.PG 323620 F	GLY.PG 323620 A
	36	30	75	112	48	43	GLY.PG 323630 F	GLY.PG 323630 A
	36	40	100	150	64	57	GLY.PG 323640 F	GLY.PG 323640 A
35	39	20	54	80	34	31	GLY.PG 353920 F	GLY.PG 353920 A
	39	30	81,5	122	52	47	GLY.PG 353930 F	GLY.PG 353930 A
	39	40	110	–	68	–	GLY.PG 353940 F	–
	39	50	137	208	87	78	GLY.PG 353950 F	GLY.PG 353950 A
37	40	20	57	85	27	23	GLY.PG 374020 F	GLY.PG 374020 A
40	44	20	61	91,5	39	36	GLY.PG 404420 F	GLY.PG 404420 A
	44	30	93	140	59	53	GLY.PG 404430 F	GLY.PG 404430 A
	44	40	125	–	78	–	GLY.PG 404440 F	–
	44	50	156	236	98	89	GLY.PG 404450 F	GLY.PG 404450 A
45	50	20	69,5	104	65	52	GLY.PG 455020 F	GLY.PG 455020 A
	50	30	106	156	83	78	GLY.PG 455030 F	GLY.PG 455030 A
	50	40	140	212	110	105	GLY.PG 455040 F	GLY.PG 455040 A
	50	50	176	265	140	130	GLY.PG 455050 F	GLY.PG 455050 A
50	55	20	76,5	–	62	–	GLY.PG 505520 F	–
	55	30	116	–	93	–	GLY.PG 505530 F	–
	55	40	156	236	125	115	GLY.PG 505540 F	GLY.PG 505540 A
	55	60	236	355	185	170	GLY.PG 505560 F	GLY.PG 505560 A
55	60	20	85	127	67	63	GLY.PG 556020 F	GLY.PG 556020 A
	60	25	106	160	84	78	GLY.PG 556025 F	GLY.PG 556025 A
	60	30	129	193	100	94	GLY.PG 556030 F	GLY.PG 556030 A
	60	40	173	260	135	125	GLY.PG 556040 F	GLY.PG 556040 A
	60	50	216	325	170	155	GLY.PG 556050 F	GLY.PG 556050 A
	60	60	260	–	200	–	GLY.PG 556060 F	–

GLYCODUR® bushings

d 60–200 mm

Designation			Basic load rating dynamic		Masses Type F A		Designations Type F A	
d	D	B	Type C Type F	A	F	A	F	A
mm			kN		g		–	
60	65	20	91,5	–	75	–	GLY.PG 606520 F	–
	65	30	140	212	110	100	GLY.PG 606530 F	GLY.PG 606530 A
	65	40	190	280	145	135	GLY.PG 606540 F	GLY.PG 606540 A
	65	60	285	425	220	205	GLY.PG 606560 F	GLY.PG 606560 A
	65	70	335	500	255	240	GLY.PG 606570 F	GLY.PG 606570 A
65	70	30	153	–	120	–	GLY.PG 657030 F	–
	70	50	255	380	200	185	GLY.PG 657050 F	GLY.PG 657050 A
	70	70	360	540	275	255	GLY.PG 657070 F	GLY.PG 657070 A
70	75	40	220	–	170	–	GLY.PG 707540 F	–
	75	50	275	415	210	195	GLY.PG 707550 F	GLY.PG 707550 A
	75	70	390	585	300	275	GLY.PG 707570 F	GLY.PG 707570 A
75	80	30	–	266	–	118	–	GLY.PG 758030 A
	80	40	–	355	–	170	–	GLY.PG 758040 A
	80	60	355	530	270	255	GLY.PG 758060 F	GLY.PG 758060 A
	80	80	475	710	365	340	GLY.PG 758080 F	GLY.PG 758080 A
80	85	60	375	560	290	270	GLY.PG 808560 F	GLY.PG 808560 A
	85	100	630	950	485	450	GLY.PG 8085100 F	GLY.PG 8085100 A
85	90	30	196	290	150	145	GLY.PG 859030 F	GLY.PG 859030 A
	90	60	400	600	305	285	GLY.PG 859060 F	GLY.PG 859060 A
	90	100	670	1 000	510	475	GLY.PG 8590100 F	GLY.PG 8590100 A
90	95	60	425	640	325	300	GLY.PG 909560 F	GLY.PG 909560 A
	95	100	710	1 060	540	505	GLY.PG 9095100 F	GLY.PG 9095100 A
95	100	60	450	670	340	320	GLY.PG 9510060 F	GLY.PG 9510060 A
	100	100	750	1 120	570	530	GLY.PG 95100100 F	GLY.PG 95100100 A
100	105	60	475	710	360	335	GLY.PG 10010560 F	GLY.PG 10010560 A
	105	115	915	1 370	690	640	GLY.PG 100105115 F	GLY.PG 100105115 A
105	110	60	490	735	375	350	GLY.PG 10511060 F	GLY.PG 10511060 A
	110	115	950	1 430	725	675	GLY.PG 105110115 F	GLY.PG 105110115 A
110	115	60	520	780	395	370	GLY.PG 11011560 F	GLY.PG 11011560 A
	115	115	1 000	1 500	760	705	GLY.PG 110115115 F	GLY.PG 110115115 A
115	120	50	450	670	340	320	GLY.PG 11512050 F	GLY.PG 11512050 A
	120	70	630	950	480	450	GLY.PG 11512070 F	GLY.PG 11512070 A
120	125	60	560	850	430	400	GLY.PG 12012560 F	GLY.PG 12012560 A
	125	100	950	1 430	715	665	GLY.PG 120125100 F	GLY.PG 120125100 A
125	130	100	980	1 500	745	695	GLY.PG 125130100 F	GLY.PG 125130100 A
130	135	60	610	915	465	435	GLY.PG 13013560 F	GLY.PG 13013560 A
	135	100	1 020	1 530	775	720	GLY.PG 130135100 F	GLY.PG 130135100 A
135	140	60	640	950	480	450	GLY.PG 13514060 F	GLY.PG 13514060 A
	140	80	850	1 270	645	600	GLY.PG 13514080 F	GLY.PG 13514080 A
140	145	60	655	980	500	465	GLY.PG 14014560 F	GLY.PG 14014560 A
	145	100	1 100	1 660	835	775	GLY.PG 140145100 F	GLY.PG 140145100 A
150	155	60	710	1 060	535	500	GLY.PG 15015560 F	GLY.PG 15015560 A
	155	80	950	1 430	715	665	GLY.PG 15015580 F	GLY.PG 15015580 A
	155	100	1 200	1 800	890	830	GLY.PG 150155100 F	GLY.PG 150155100 A
160	165	80	1 000	–	780	–	GLY.PG 16016580 F	–
	165	100	1 270	–	970	–	GLY.PG 160165100 F	–
180	185	100	1 430	–	1 100	–	GLY.PG 180185100 F	–
200	205	100	1 600	–	1 200	–	GLY.PG 200205100 F	–



GLYCODUR® flanged bushings

d 5–35 mm

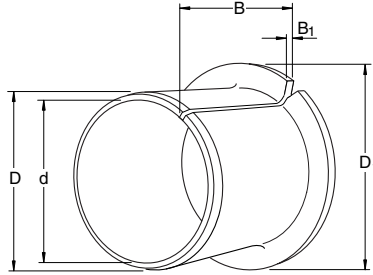

Dimensions					Basic load rating		Mass	Designation
d	D	D ₁	B	B ₁	dynamic radial C	axial C _a		
mm					kN		g	–
5	7	11,5	4	1	0,800	2,85	1,0	GLY.PBG 050704 F
6	8	12	4	1	0,965	2,75	1,3	GLY.PBG 060804 F
	8	12	8	1	2,9	2,75	1,9	GLY.PBG 060808 F
8	10	15	5,5	1	2,24	5,10	2,1	GLY.PBG 081005.5 F
	10	15	7,5	1	3,55	5,10	2,5	GLY.PBG 081007.5 F
	10	15	9,5	1	4,8	5,10	2,9	GLY.PBG 081009.5 F
10	12	18	6	1	3,2	8	2	GLY.PBG 101206 F
	12	18	7	1	4	8	3,1	GLY.PBG 101207 F
	12	18	9	1	5,6	8	3,6	GLY.PBG 101209 F
	12	18	12	1	8	8	4,3	GLY.PBG 101212 F
	12	18	17	1	12	8	5,6	GLY.PBG 101217 F
	12	18	20	1	14,4	8	4,8	GLY.PBG 101220 F
12	14	20	7	1	4,8	9,15	3,6	GLY.PBG 121407 F
	14	20	9	1	6,7	9,15	4,2	GLY.PBG 121409 F
	14	20	12	1	9,65	9,15	5,1	GLY.PBG 121412 F
	14	20	15	1	12,5	9,15	6,1	GLY.PBG 121415 F
	14	20	17	1	14,3	9,15	6,6	GLY.PBG 121417 F
14	16	22	12	1	11	10	5,8	GLY.PBG 141612 F
	16	22	17	1	16,6	10	7,5	GLY.PBG 141617 F
15	17	23	9	1	8,3	10,4	5,1	GLY.PBG 151709 F
	17	23	12	1	12	10,4	6,2	GLY.PBG 151712 F
	17	23	17	1	18	10,4	7,6	GLY.PBG 151717 F
16	18	24	12	1	12,2	8,5	6,2	GLY.PBG 161812 F
	18	24	17	1	18,6	8,5	8,1	GLY.PBG 161817 F
18	20	26	12	1	13,7	9,3	7,3	GLY.PBG 182012 F
	20	26	17	1	20,8	9,3	9,5	GLY.PBG 182017 F
	20	26	22	1	28	9,3	12	GLY.PBG 182022 F
20	23	30	11,5	1,5	14,3	17,3	13	GLY.PBG 202311.5 F
	23	30	15	1,5	20	17,3	16	GLY.PBG 202315 F
	23	30	16,5	1,5	22	17,3	17	GLY.PBG 202316.5 F
	23	30	21,5	1,5	30,5	17,3	21	GLY.PBG 202321.5 F
25	28	35	11,5	1,5	17,3	20,4	16	GLY.PBG 252811.5 F
	28	35	16,5	1,5	28	20,4	21	GLY.PBG 252816.5 F
	28	35	21,5	1,5	37,5	20,4	25	GLY.PBG 252821.5 F
30	34	42	16	2	30,5	29	35	GLY.PBG 303416 F
	34	42	26	2	54	29	50	GLY.PBG 303426 F
35	39	47	16	2	35,5	33,5	43	GLY.PBG 353916 F
	39	47	26	2	63	33,5	61	GLY.PBG 353926 F

GLYCODUR® thrust washers
d 10–62 mm

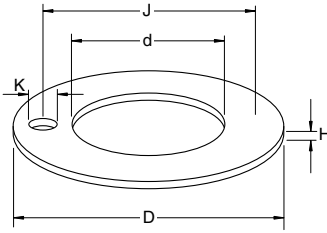

GLY.PXG .. F

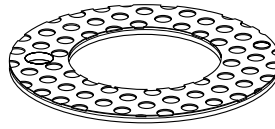

GLY.PXG .. A

Dimensions					Basic load rating		Masses		Designations		
d	D	H	J	K	dynamic	Type	Type	F	A	F	A
mm					C	A	F				
					kN		g				
10	20	1,5	15	1,75	19	–	2,6	–		GLY.PXG 102001.5 F	–
12	24	1,5	18	1,75	28	40,5	3,8	3,2		GLY.PXG 122401.5 F	GLY.PXG 122401.5 A
14	26	1,5	20	2,25	30	45	4,2	3,6		GLY.PXG 142601.5 F	GLY.PXG 142601.5 A
16	30	1,5	23	2,25	40	–	5,6	–		GLY.PXG 163001.5 F	–
18	32	1,5	25	2,25	44	65,5	6,1	5,3		GLY.PXG 183201.5 F	GLY.PXG 183201.5 A
20	36	1,5	28	3,25	56	85	7,8	6,7		GLY.PXG 203601.5 F	GLY.PXG 203601.5 A
22	38	1,5	30	3,25	60	90	8,4	7,2		GLY.PXG 223801.5 F	GLY.PXG 223801.5 A
26	44	1,5	35	3,25	78	118	11	9,4		GLY.PXG 264401.5 F	GLY.PXG 264401.5 A
28	48	1,5	38	4,25	93	140	13	11		GLY.PXG 284801.5 F	GLY.PXG 284801.5 A
32	54	1,5	43	4,25	116	176	16	14		GLY.PXG 325401.5 F	GLY.PXG 325401.5 A
38	62	1,5	50	4,25	150	224	21	18		GLY.PXG 386201.5 F	GLY.PXG 386201.5 A
42	66	1,5	54	4,25	163	240	23	19		GLY.PXG 426601.5 F	GLY.PXG 426601.5 A
48	74	2	61	4,25	200	300	37	34		GLY.PXG 487402 F	GLY.PXG 487402 A
52	78	2	65	4,25	208	315	39	36		GLY.PXG 527802 F	GLY.PXG 527802 A
62	90	2	76	4,25	265	–	45	–		GLY.PXG 629002 F	–

Design of bearing arrangements

What to remember when designing	page 187
How to choose the right type of bearing	page 188
Load carrying capacity and life	page 192
When to use software.....	page 194
When to contact the SKF application engineering service	page 195
Where to find relevant information	page 195

What to remember when designing

A rolling bearing arrangement consists not only of the bearing(s), but also of the adjacent components such as:

- 1 the shaft (axle or spindle) which transmits the radial and axial forces as well as rotation and torque,
- 2 the housing which has to take up the forces and loads acting on the bearing(s),
- 3 the seals which have to prevent lubricant from leaving, and moisture and/or solid contaminants from entering the bearing position,
- 4 other components such as spacer sleeves, end covers, retaining rings, nuts etc., and last but not least
- 5 the lubricant which has to prevent metallic contact between the various components of the bearings, reduce wear and protect the metallic surfaces against corrosion.

The design of a bearing arrangement, therefore, does not consist solely of choosing a suitable bearing type and size, but requires several more steps: the type and quantity of lubricant must be decided, the fits and bearing internal clearance must be chosen, the various other component parts must be appropriately designed, the seals must be selected etc. Each separate step affects the

function, operational reliability and economy of the bearing arrangement.

The time and effort required depend on whether experience is available of similar bearing arrangements. When there is no experience, when exceptional demands are placed on the arrangement or when it is necessary to pay special attention to the cost of

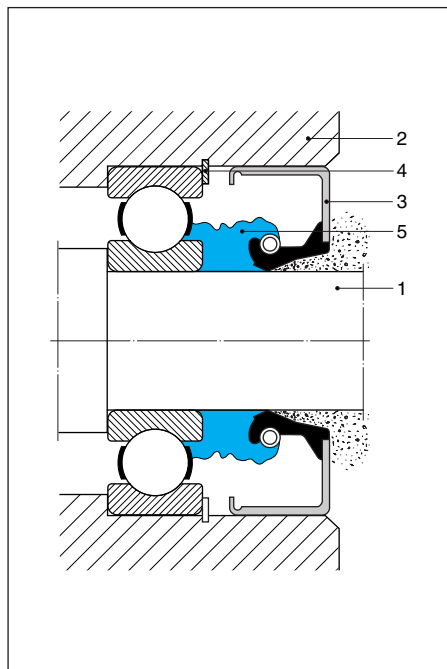

the arrangement itself, or to subsequent costs, then the amount of work involved will increase, as more detailed calculations and/or testing are needed, for example.

It is apparent that the design of a bearing arrangement requires a good deal of experience and a basic knowledge of mechanics. Where these are available, the information provided in the SKF General Catalogue 4000 should suffice. If not, there is an interactive learning program “SKF Electronic Handbook” available, which can be used to perform all the necessary calculations, and will explain all the other steps at the “click” of a button. The PC software makes learning fun. Why not order it now.

How to choose the right type of bearing

As already explained, the SKF General Catalogue should be used when designing a bearing arrangement. The General Catalogue contains 170 pages covering basic bearing knowledge of a total of almost 1 000 pages. It is essentially a bearing technology handbook and is a particularly useful reference work.

To provide an insight into the many aspects which have to be considered when choosing a bearing, the main points are listed in the following. Obviously, any choice will almost always have to be a compromise as it is necessary to weigh the various demands against each other.

- 1 Available space
- 2 Type and magnitude of the load
 - a) radial load
 - b) axial load
 - c) combined load
 - d) moment load
- 3 Compensation for errors of alignment
- 4 Axial displacement of a non-locating bearing
- 5 Can the bearing be mounted

as well as

- Accuracy of the bearing arrangement
- Stiffness of the bearing arrangement
- Operating speeds
- Requirements for quiet running

It should also be remembered that the total cost of the bearing arrangement as well as any need to stock spare bearings must be considered when making the choice.

The matrix on pages 190 and 191 provides an overview of the different bearing types, their characteristics, and their suitability to meet the various demands placed on a bearing arrangement.

1



2

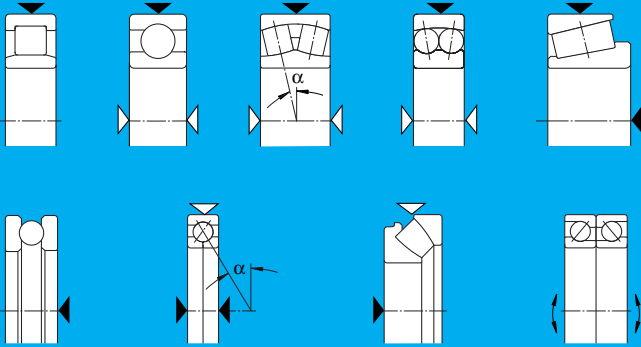

3

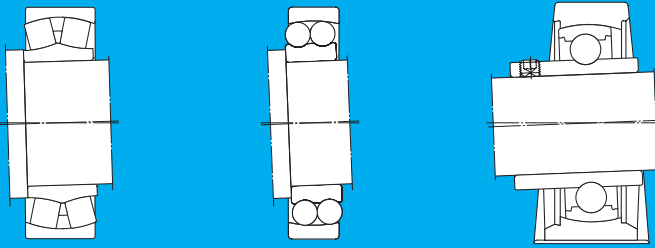

4



5

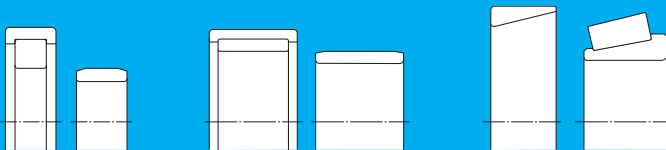

Design of bearing arrangements

This matrix can only provide a rough overview of the design and characteristics of the various bearing types. If several designs of a bearing type are shown adjacent to each other, the relevant information is indicated by the same small letter used to identify the individual design.

Symbols:
 +++ excellent — poor
 ++ good — unsuitable
 + fair → single direction
 ↔ double direction

Bearing types – design and characteristics

Design

Bearing type	tapered bore	shields or seals	self-aligning	non-separable	separable
Deep groove ball bearings					
Self-aligning ball bearings					
Angular contact ball bearings					
(back-to-back)		a			
Four-point contact ball bearings					
Cylindrical roller bearings					
Full complement cylindrical roller bearings					
Needle roller bearings					
Spherical roller bearings					
Taper roller bearings					
Thrust ball bearings					
Cylindrical roller thrust bearings					
Needle roller thrust bearings					
Spherical roller thrust bearings					

Characteristics
Suitability of bearings for

purely radial load	purely axial load	combined load	moment load	high speed	high running accuracy	high stiffness	quiet running	low friction	compensation for misalignment in operation	compensation for errors of alignment (initial)	locating bearing arrangements	non-locating bearing arrangements	axial displacement possible in bearing
+	↕	+	-	+++	+++	+	+++	+++	-	-	++	+	--
+	↕	+	+	+	+	+	+	++	--	--	+	+	--
+	-	-	--	++	++	-	++	++	+++	++	+	+	--
+	↕	++	-	++	+++	+	++	++	-	-	++	--	--
++	↕	++	+	+	++	++	+	+	--	--	++	+	--
-	↕	+	+	++	+	+	+	+	--	--	++	-	--
++	--	--	--	+++	++	++	++	++	-	-	--	+++	+++
++	--	+	--	+++	++	++	+	++	-	-	+	^a	^a
+++	--	--	+	+++	+++	+++	++	++	--	--	--	+++	+++
+++	--	-	--	-	+	+++	-	-	-	-	+	+	+
+++	--	-	+	-	+	+++	-	-	--	--	+	+	--
++	--	--	--	+	+	++	+	-	--	--	--	+++	+++
+++	↕	+++	--	+	+	++	+	+	+++	++	++	+	--
++	↕	+++	--	+	++	++	+	+	-	-	++	--	--
--	^a ^b	--	--	+	⁺⁺ ^a	+	-	+	--	--	+	--	--
--	↕	--	--	+	+	+	-	+	--	+++	+	--	--
--	↕	--	--	-	++	++	-	-	--	--	+	--	--
--	↕	--	--	-	+	++	-	-	--	--	+	--	--
--	↕	+	--	+	+	++	-	+	+++	++	++	--	--

Load carrying capacity and life

The size of bearing required for a given bearing position is determined by the load carrying capacity of the bearing in relation to the loads acting at this position and the required bearing life and operational reliability. Load carrying capacity is expressed as a basic load rating. There are two: the basic dynamic load rating C and the basic static load rating C_0 . Values of the basic dynamic load rating C which are required to calculate life are given in the bearing tables.

Basic load ratings

The basic dynamic load rating C is used when selecting bearings which are to be dynamically stressed, i.e. are to rotate under load. The rating is defined as that constant bearing load (radial for radial bearings, and axial for thrust bearings acting centrally) under which a bearing life of one million revolutions will be obtained.

The basic dynamic load ratings of SKF bearings are calculated in accordance with ISO 281:1993.

The basic static load rating C_0 is used to ensure that a bearing is not overloaded when operating at very slow speeds, when performing slow oscillating movements or when standing still. It should also be considered when a dynamically stressed bearing is subjected to heavy shock loads of short duration.

The basic static load rating C_0 is defined in ISO 76:1987 as the load which will produce a certain pressure in the most heavily loaded rolling element/raceway contact. This pressure is approximately that required to produce a permanent deformation of 0,0001 times the rolling element diameter.

Life

The life of a bearing (when not otherwise stated) is a fatigue life and is the number of revolutions, or operating hours, for which the bearing will run before the first sign of fatigue (flaking or spalling) on a rolling element or ring raceway can be detected.

It has been observed in the laboratory as well as in practice, that seemingly identical

bearings under identical operating conditions have different lives. It is therefore necessary to accurately define life in order to calculate the requisite bearing size. The definition used is that for the basic rating life given in ISO 281:1993 on which all data regarding the dynamic load carrying capacity of SKF bearings are based. This basic rating life is the life which 90 % of a large number of seemingly identical bearings will attain or exceed. Most bearings live much longer, half of them about five times longer.

“Service life” is another term used. By this is meant the time during which a given bearing in a given application remains operational. The service life is not usually ended by fatigue, but generally by wear, corrosion, or damage caused by seal failure etc.

Selecting bearing size based on life

The more accurately the bearing operating conditions are known, or can be determined, the more precisely the life can be calculated.

Here, only the simplest procedure will be presented. This enables a rough estimation of the bearing life to be made for a given application. The basic dynamic load ratings needed for this are given in the bearing tables. It is, however, first necessary to know or to be able to determine the loads acting on the bearing, see under “Equivalent dynamic bearing load” below.

The simplest life calculation is that of the basic rating life L_{10} according to ISO, using the equation

$$L_{10} = \left(\frac{C}{P}\right)^p$$

When the operating speed is constant, it may be more sensible to calculate the basic rating life in hours using

$$L_{10h} = \frac{1\,000\,000}{60\,n} \left(\frac{C}{P}\right)^p$$

where

L_{10} = basic rating life, million revolutions

L_{10h} = basic rating life, operating hours

C = basic dynamic load rating, N

P = equivalent dynamic bearing load, N

- n = rotational speed, r/min
- p = exponent of the life equation,
 - p = 3 for ball bearings
 - p = 10/3 for roller bearings

Using the adjusted rating life (to ISO 281) it is possible to take into account the influences of bearing material and lubrication and using the SKF New Life Theory it is possible to include other factors, including contamination. For more details, please refer to the SKF General Catalogue.

Equivalent dynamic bearing load

The load acting on a bearing can be determined using the laws of mechanics, when the external forces (e.g. deriving from the power transmission, work forces or mass forces) are known or can be determined.

This load does not usually fulfil the requirements relating to the basic load rating (load which is constant in magnitude and direction, being purely radial for radial bearings and purely axial and acting centrally for thrust bearings). Therefore, it is generally necessary to first calculate the equivalent dynamic bearing load, P. This is defined as that radial or axial load, constant in magnitude and direction, which would have the same influence on bearing life as the actual loads experienced by the bearing.

All the information required to calculate the equivalent bearing loads will be found in the SKF General Catalogue. To include all the details here would be to exceed the scope of this catalogue.

When to use software

Practical experience and recent research results show that SKF ball and roller bearings have a very much longer life under certain conditions than that calculated using the standardised life equations. The certain conditions are when the raceways of the rings and rolling elements are effectively separated by a film of lubricant, a certain (fatigue) load limit is not exceeded and there is virtually no risk of any damage being caused to the bearing surfaces by the presence of contamination.

The SKF New Life Theory is an extension of the Lundberg-Palmgren bearing fatigue life theory, and enables the influence of lubrication and contamination on bearing life to be considered, in addition to the fatigue load limit. It is thus possible, using the SKF New Life Theory and the SKF General Catalogue, to predict bearing life more precisely.

To make full use of the potential of the New Life Theory, the operating conditions must be very accurately known, and it is generally necessary to employ a computer for the calculations. The following software is available from SKF.

SKF CADalog

SKF CADalog is a bearing selection and calculation program. The program calculates and selects bearings based on one or more of the following parameters: shaft diameter, housing bore diameter, bearing width, basic rating life and static safety factor. The bearing data is stored in a data base, which covers nearly all the bearings shown in SKF catalogues.

The CADalog software also includes routines for drawing all the bearings stored in the data base. It can be used with most CAD systems.

There is a small administrative fee for SKF CADalog. Further information can be obtained directly from SKF.

PC.adam

PC.adam is another software package from SKF which is dedicated to the calculation of statically determinate bearing arrangements. This is normally the case in practice.

PC.adam is primarily intended for the design of gearboxes and allows the bearing arrangement to be calculated giving

- the basic rating life to ISO 281,
- the adjusted rating life to ISO 281, and
- the adjusted rating life according to the SKF New Life Theory.

PC.adam contains all data of the bearings shown in the SKF General Catalogue. The calculations are made, taking into account the type of gear, the performance data and the geometry. In addition to bearing life, the program also calculates the tooth forces and the loads acting on the bearing and these results are also displayed. PC.adam reduces calculation times from several hours to a few minutes. It is IBM-compatible and available on diskettes.

Again there is a small charge for the program; more information can be obtained directly from SKF.



When to contact the SKF application engineering service

There are applications where it is very important to obtain predictions of the performance and life of the bearings which are as exact as possible. This may be because there is insufficient experience available with similar bearing arrangements, or because the economy and/or operational reliability are of vital importance. In such cases it is recommended to get in touch with the SKF application engineering service. This has as its disposal a wealth of knowledge and experience which has been gathered worldwide with all different kinds of bearing applications. The service is therefore capable of providing advice, even for difficult cases.

The SKF application engineering service also has access to sophisticated computer programs which can perform a variety of complex calculations including

- the influence on bearing life of the internal clearance or preload in operation, the actual contact conditions in the bearing, misalignments, housing deformations etc., and
- the very complicated calculation of statically indeterminate three-bearing arrangements.

These SKF in-house programs enable a realistic analysis to be made of the force and moment distribution between the bearings and a more accurate determination of life. The benefits of using the SKF application engineering service include the trustworthiness of the advice and calculation results. Further information can be obtained by contacting SKF directly.

Where to find relevant information

If there is a need to obtain more detailed information about the design of bearing arrangements, or about certain specific topics, then the alphabetical index which follows should be helpful. The first number given in the reference is the publication number of the catalogue or leaflet and the second number (after the colon :) the page number, e.g. 4000:40 refers to the General Catalogue 4000, page 40.

The SKF publications referred to in the index are as follows:

3500	Plain bearings
3700	Precision bearings
4000	General catalogue
4005	Bearing housings
4006	CR seals
4100	Bearing Maintenance Handbook
PI 100	Product designations for rolling bearings and accessories
PI 303	SKF oil injection method

Design of bearing arrangements

Subject	Reference
Accuracy	3700; 4000:124
Additional forces	4000:48
Adjustment of bearings	4000:136
Aligning shafts	4100:94
Alignment errors	4100:94
Application of bearings	4000:98
Axial displacement	4000:22, 101
Axial internal clearance	4000:88
Basic load ratings	4000:27
Bearing arrangement design	4000:98
Bearing designations	PI 100; 4100:36
Bearing housings	4005
Bearing internal clearance	4000:88
Bearing loads	4000:16
Bearing seatings	4100:282
Bearing size, selection of	4000:26
Bearing temperature	4000:33
Bearing types	4000:9
Cages	4000:90
Chamfer dimensions	4000:70, 73, 86
Contact angle	4000:286
Corrosion, protection against	4000:162; 4100:248
Damage analysis	4100:54
Dimension Series, Dimensions	4000:68
Dismounting	4000:170; 4100:100
Dynamic load carrying capacity	4000:27
Equivalent load	
Equivalent dynamic bearing load	4000:49
Equivalent static bearing load	4000:52
Fatigue	4000:26
Fits	4000:102
Form errors	4000:124
Friction (also coefficient of)	4000:56
Grease	4000:150; 4100:210
Grease escape valve	4100:23
Grease lubrication	4000:149; 4100:210
Hollow shafts	4000:122
Hydraulic nuts, mounting with	4000:916; 4100:98
Life	
Basic rating life to ISO 281	4000:28
Adjusted rating life to ISO 281	4000:35
Adjusted rating life to SKF New Life Theory	4000:40
Loads	4000:16
Locating bearing	4000:98
Location of bearing rings	
Axial location	4000:128
Radial location	4000:100
Lubrication	4000:148; 4100:208
Maintenance	4000:162
Maintenance, computer aided	4100:42
Materials	4000:89

Minimum load	4000:50
Misalignment, shaft	4100:94
Mounting	4000:164; 4100:128
Non-locating bearing	4000:98
Oil	4100:234
Oil change	4000:161
Oil injection method	PI 303; 4100:96
Oil lubrication	3700:223; 4000:157; 4100:234
Paired bearings	4000:141
Point load	4000:100
Precision	3700; 4000:124
Preload	4000:131
Radial internal clearance	4000:88
Radial runout	4000:73
Relubrication, Relubrication intervals	4000:154; 4100:228
Re-use of bearings	4100:117
Rotating load	4000:100
Seal, selection of	4006:12
Sealing	4000:142; 4006:7
Sealing arrangement design	4006:12
Seals	
Axial clamp seals.....	4006:219
Housing seals	4000:762; 4100:169
Mechanical seals	4006:191
Radial shaft seals	4006:51
V-ring seals	4006:197
Service life of	
GLYCODUR bearings	3500:149
Rod ends	3500:23
Spherical plain bearings	3500:23
Space, available	4000:15
Speeds, Speed ratings	4000:64
Static load carrying capacity	4000:53
Static safety factor	4000:53
Stiffness	3700:18; 4000:21
Storage, bearings	4100:248
Storage, seals	4006:46
Surface finish	4000:127
Tolerances	4000:70; 4100:250



SKF

1 Optical bearing 1 angle